



INSTRUCTIONS—INSTRUCCIONES—CONSIGNES

APPLICATION: 2007-2013 FORD EDGE & LINCOLN MKX
APP PART # 65-1105
CLASS III RECEIVER HITCH

ITEM	QUANTITY	DESCRIPTION	TOOLS NEEDED
1	1	CLASS III RECEIVER ASSY	18MM SOCKET
2	6	M12 SPLIT LOCK WASHER	RATCHET
3	6	M12 HEX NUT	TORQUE WRENCH
4	6	M12 FLAT WASHER	8MM SOCKET
5	6	M12 STUD PLATE	METAL SHEARS
6	2	M12 FISHWIRE TOOL	

WARNING: Never exceed the capacity ratings shown on the receiver hitch or the tow vehicle. See your vehicle's owners guide for towing guidelines.

1. Remove contents from box, verify if all parts listed are present and free from damage. Carefully read and understand all instructions before attempting installation.
2. To ease installation, the rear portion of the exhaust system should be dropped. This can be accomplished by removing the three rear rubber exhaust hangers. A strap of some kind should be used on a forward portion of the exhaust to provide support to prevent damage. FIGURE 1
3. There are two silver colored steel plates that must be removed in order to proceed with the installation. These will be re-attached with the tabs trimmed. FIGURE 2
4. At the driver side uni-body channel. Guide one M12 stud plate into the two front most mounting hole through the rear of the uni-body channel using the provided M12 fishwire tool. Perform for both the driver and passenger side channels. FIGURE 3,4
5. The tabs for the steel plates need to be trimmed to allow access to the rear most holes. The plate can then be reinstalled using the remaining factory screws.
6. The hitch assembly can now be raised to the uni-body channels. Fasten the hitch to the already installed stud plates with the provided M12 flat washers, split lock washers and hex nuts. No not fully tighten at this time. FIGURE 5,6
7. At the rearmost holes of the hitch assembly, Drill a 1/2"-9/16" hole through the hitch bracket and the uni-body sheet metal. Then an additional M12 stud plate can be placed inside each channel. Fasten each side with the provided M12 flat washer, split lock washer, and hex nut. FIGURE 7
8. Align the hitch assembly as desired then torque all M12 hex nuts to 75-80 lbs-ft. The exhaust can now be re-attached to the chassis using the original rubber hangers. FIGURE 8

NOTICE: This product complies with all safety specifications and requirements defined for V.E.S.C. regulation V-5 & SAE J684

CARE INSTRUCTIONS

- BLACK FINISHES SHOULD BE CLEANED WITH MILD SOAP AND WATER



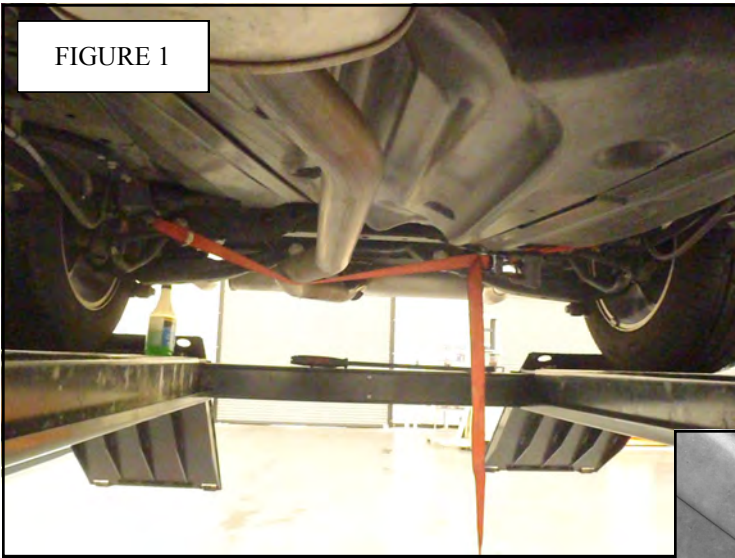
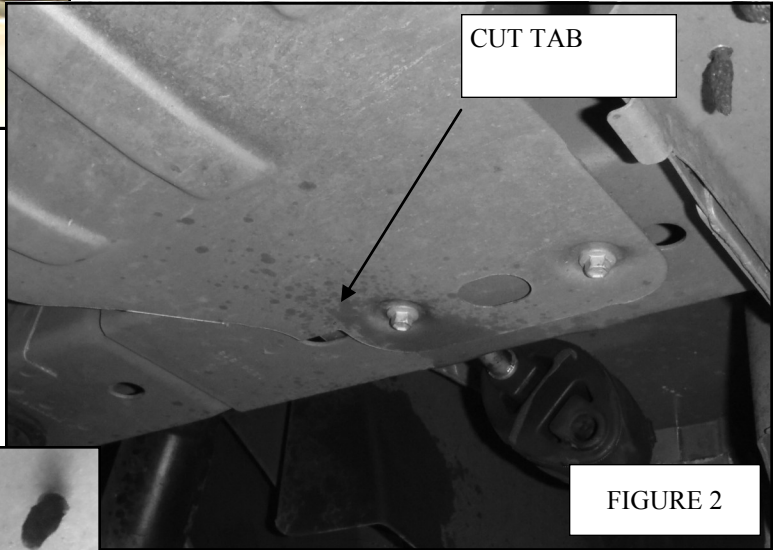
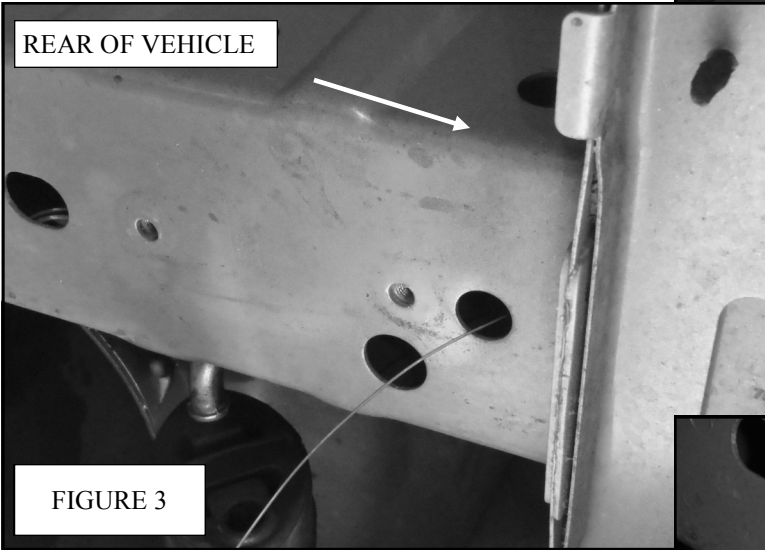

FIGURE 1



CUT TAB

FIGURE 2



REAR OF VEHICLE

FIGURE 3

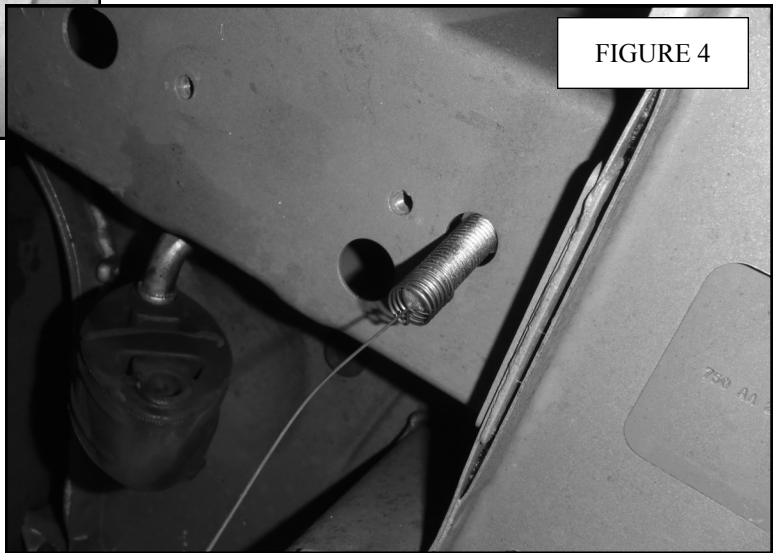
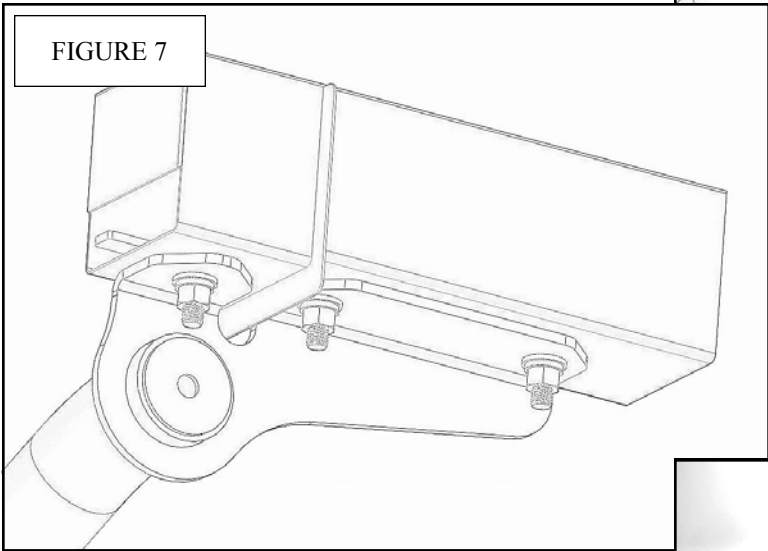
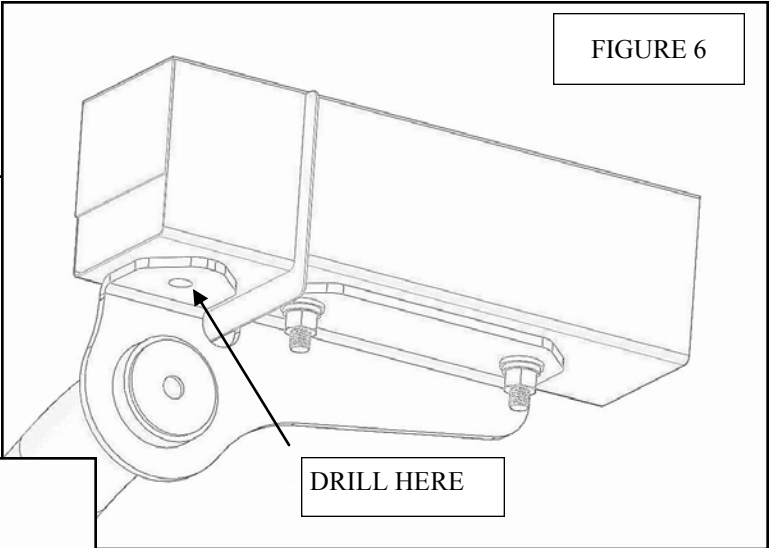
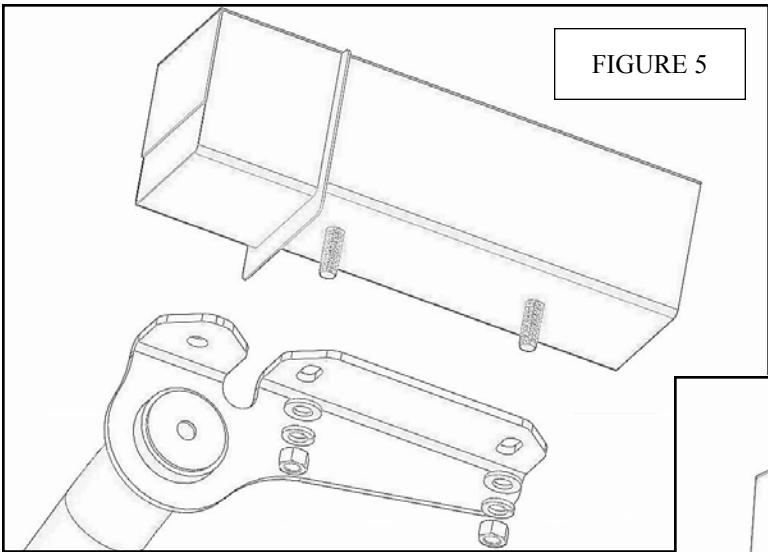

FIGURE 4





WARNINGS & NOTICES FOR THE INSTALLATION OF WESTIN TOWING PRODUCTS - CLASS III RECEIVER HITCH

NOTICE

Westin Receiver Hitches are designed to accommodate a 2"- square receiver draw bar rated for class III/IV towing. Closely follow all Westin Installation Instructions for the proper installation of product. Improper installation can result in death, serious injury, and/or product and vehicle damage. In the operation of these products, it is imperative to observe precautions for your personal safety and the safety of others.

WARNING

Failure to follow these instructions could lead to death, personal injury, and / or property damage.

FASTENERS:

All Westin supplied fasteners must be utilized and installed in accordance with the installation instructions and apply torque to the specifications as defined. **DOUBLE CHECK ALL FASTENERS BEFORE INITIAL USE, AND PERIODICALLY IN THE FUTURE TO ENSURE PROPER FUNCTION AND SAFETY.**

DRILLING:

Most Westin products do not require drilling for installation. If drilling is defined as required, use caution when drilling a vehicle. **FAILURE TO REVIEW AN AREA TO BE DRILLED MAY RESULT IN PERSONAL INJURY AND/OR INJURY TO OTHERS AS WELL AS VEHICLE DAMAGE.**

EYE PROTECTION:

ALWAYS WEAR SAFETY GLASSES OR GOGGLES DURING THE INSTALLATION PROCESS TO AVOID PERSONAL INJURY.

MAXIMUM TOWING/CARRYING CAPACITY:

The Westin Receiver Hitches will have a visible tow rating label affixed directly on the product. User should never exceed the vehicle manufacturers maximum tow and weight rating regardless of the capacity of the hitch. **FAILURE TO FOLLOW THESE GUIDELINES WILL VOID THE WESTIN WARRANTY AND MAY RESULT IN PERSONAL INJURY AND/OR INJURY TO OTHERS AS WELL AS VEHICLE DAMAGE.**



P.N.: 75-65110 REV A