



SIGNATURE OF QUALITY

AUTOMOTIVE PRODUCTS, INC.

INSTRUCTIONS

CLASS 1 RECEIVER HITCH

APPLICATION: 2008-2013 NISSAN ROGUE (EXCLUDING KROM PACKAGE)

APP PART # 65-1335

ITEM	QUANTITY	DESCRIPTION	TOOLS NEEDED
1	1	<u>MAIN RECEIVER HITCH ASSEMBLY</u>	18MM SOCKET
2	1	DRIVER SIDE MOUNTING BRACKET	16MM SOCKET
3	1	PASSENGER SIDE MOUNTING BRACKET	
4	6	M12 CAP SCREW	
5	6	M12 SPLIT LOCK WASHER	
6	6	M12 FLAT WASHER	
7	8	M10 CAP SCREW	
8	8	M10 SPLIT LOCK WASHER	
9	8	M10 FLAT WASHER	

ANTI-SEIZE LUBRICANT MUST BE USED ON ALL STAINLESS STEEL FASTENERS TO PREVENT THREAD DAMAGE AND GALLING

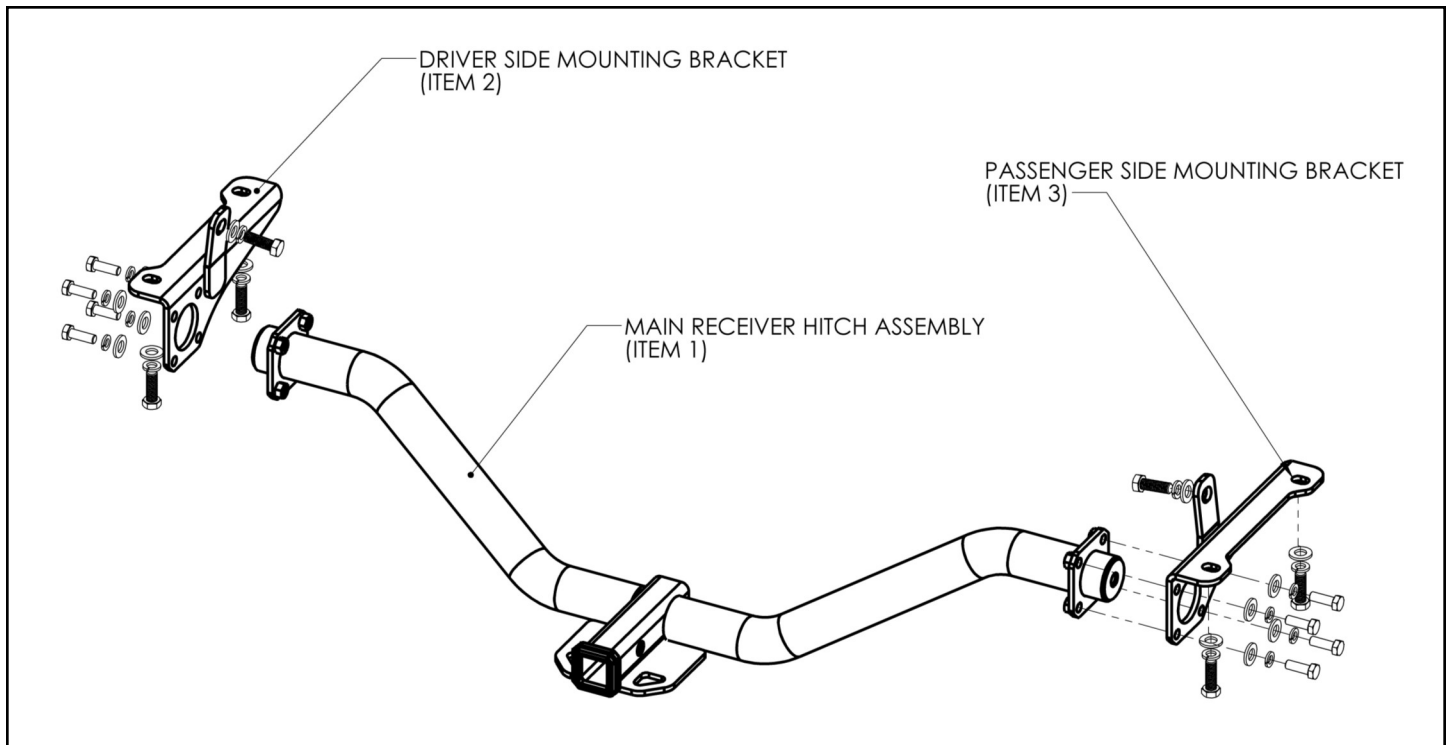

CARE INSTRUCTIONS

- REGULAR WAXING IS RECOMMENDED. DO NOT USE ANY TYPE OF POLISH OR WAX THAT MAY CONTAIN ABRASIVES.
- STAINLESS STEEL PRODUCTS CAN BE CLEANED WITH MILD SOAP AND WATER. STAINLESS STEEL POLISH SHOULD BE USED TO POLISH SMALL SCRATCHES.
- GLOSS BLACK FINISHES SHOULD BE CLEANED WITH MILD SOAP AND WATER.



SIGNATURE OF QUALITY

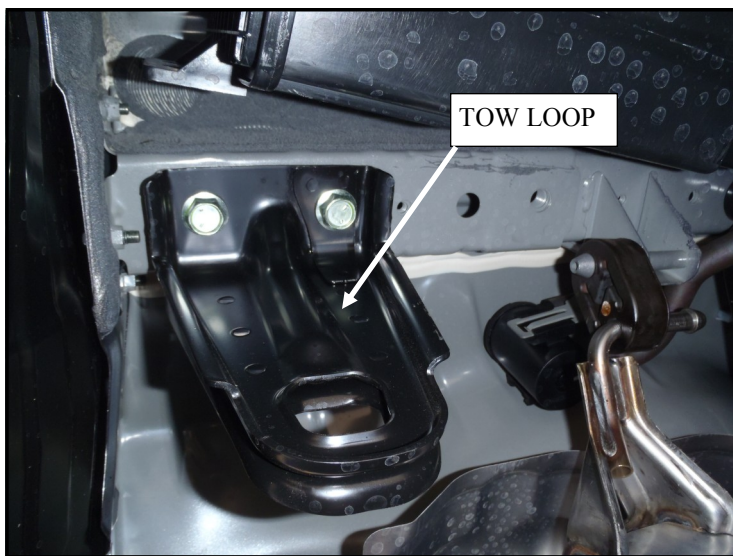
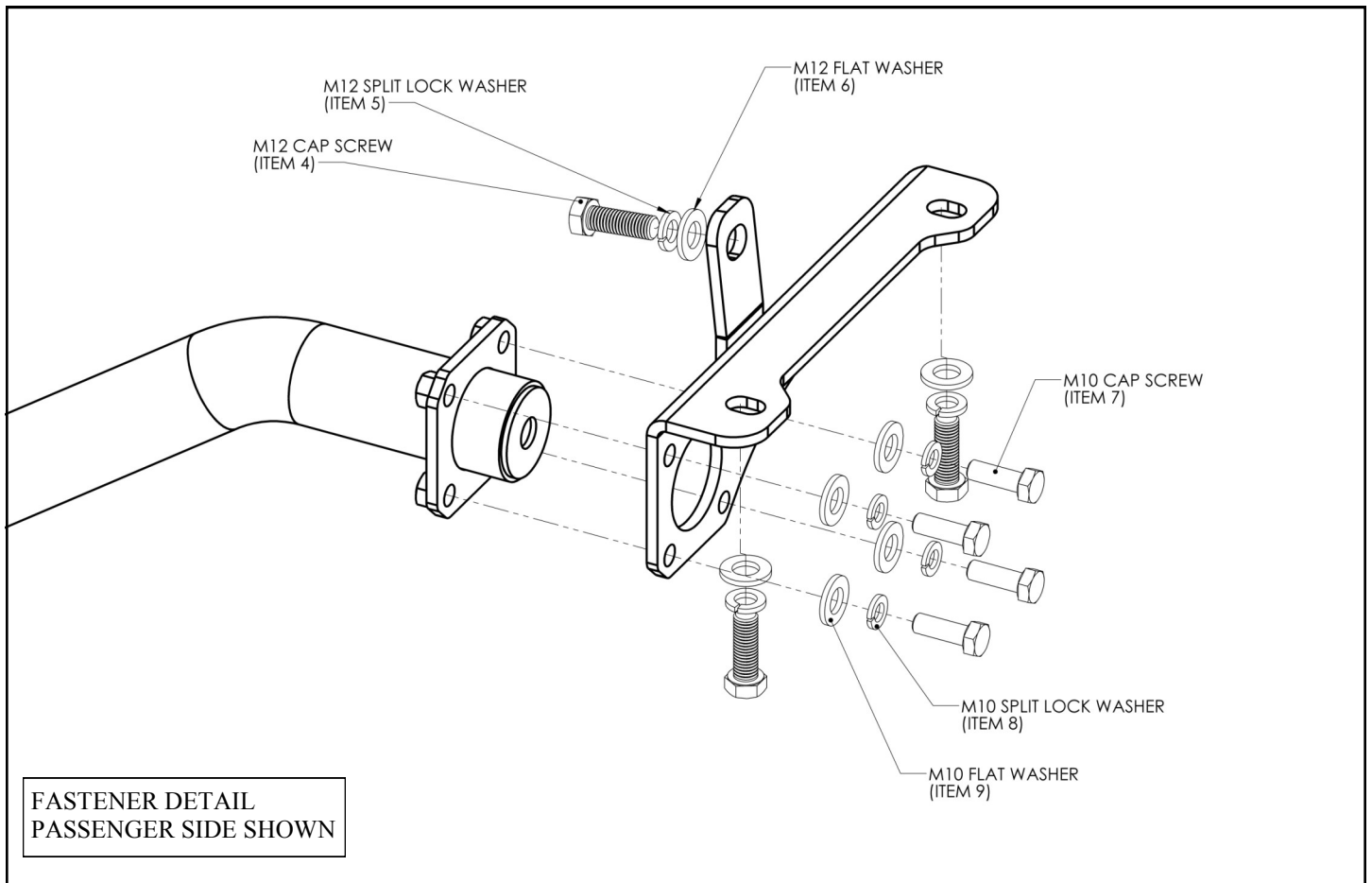

1. Remove contents from box, verify if all parts listed are present and free from damage. Carefully read and understand all instructions before attempting installation.
2. Starting at the rear underside of the vehicle, remove the original tow loop from the unibody channel. This will be replaced after product is installed.

3. Refer to the fastener detail illustration for the fasteners at the beginning of page two. First, loosely attach the driver and passenger side mounting brackets to the vehicle unibody channel using the supplied M12 cap screws, split lock washers, and flat washers. Do not fully tighten at this time.

4. With the mounting brackets loose, attach the main hitch assembly to each mounting bracket using the supplied M10 cap screws, M10 split lock washers, and M10 flat washers. Do not fully tighten at this time.



5. Adjust all components as desired. Tighten M12 fasteners to 60-65 lb-ft & M10 fasteners to 30-35 lb-ft

