



INSTALLATION INSTRUCTIONS

POLICE PIT BAR

APPLICATION:

Ford Interceptor Utility 2011-2016

PART NUMBER:

36-2005PB, 36-2055PB

AUTOMOTIVE PRODUCTS,

ITEM	QUANTITY	DESCRIPTION	TOOLS NEEDED
1,2	2	PIT BAR RAIL ASSEMBLIES (DRV & PASS)	RATCHET
3,4	2	INNER MOUNTING BRACKETS (DRV & PASS)	SCREWDRIVER
5,6	2	INNER SUPPORT BRACKETS (DRV & PASS)	14MM WRENCH
7	2	LONG SPACERS (36-2005PB ONLY)	14MM SOCKET
8	2	SHORT SPACERS (36-2005PB ONLY)	ALLEN WRENCH
9	1	M6 FLANGE BOLT	18MM WRENCH
10	1	M6 FLANGE NUT	15MM SOCKET
11	2	M12 FLANGE BOLT	13MM SOCKET
12	6	M12 FLANGE NUT	10MM SOCKET
13	2	M12 LONG SOCKET HEAD CAP SCREW (36-2005PB ONLY)	8MM SOCKET
14	2	M12 MEDIUM SOCKET HEAD CAP SCREW (36-2005PB ONLY)	6MM SOCKET
15	4	M12 WASHER	RATCHET EXT.
16	2	M10 BUTTON HEAD SCREW	TORQUE WRENCH
17	2	M10 CUPPED WASHER (6 FOR 36-2055PB)	TRANSFER PUNCH
18	2	M10 FLANGE NUT (6 FOR 36-2055PB)	HOLE SAW
19	4	1.50" RUBBER GROMMETS (36-2005PB ONLY)	UTILITY KNIFE
20	4	M12 HEX HEAD BOLT (36-2055PB ONLY)	
21	4	M10 HEX HEAD BOLT (36-2055PB ONLY)	
22,23	2	PIT BAR MOUNTING BRACKETS-(DRV & PASS) (36-2055 ONLY)	

ANTI-SEIZE LUBRICANT MUST BE USED ON ALL STAINLESS STEEL FASTENERS TO PREVENT THREAD DAMAGE AND GALLING

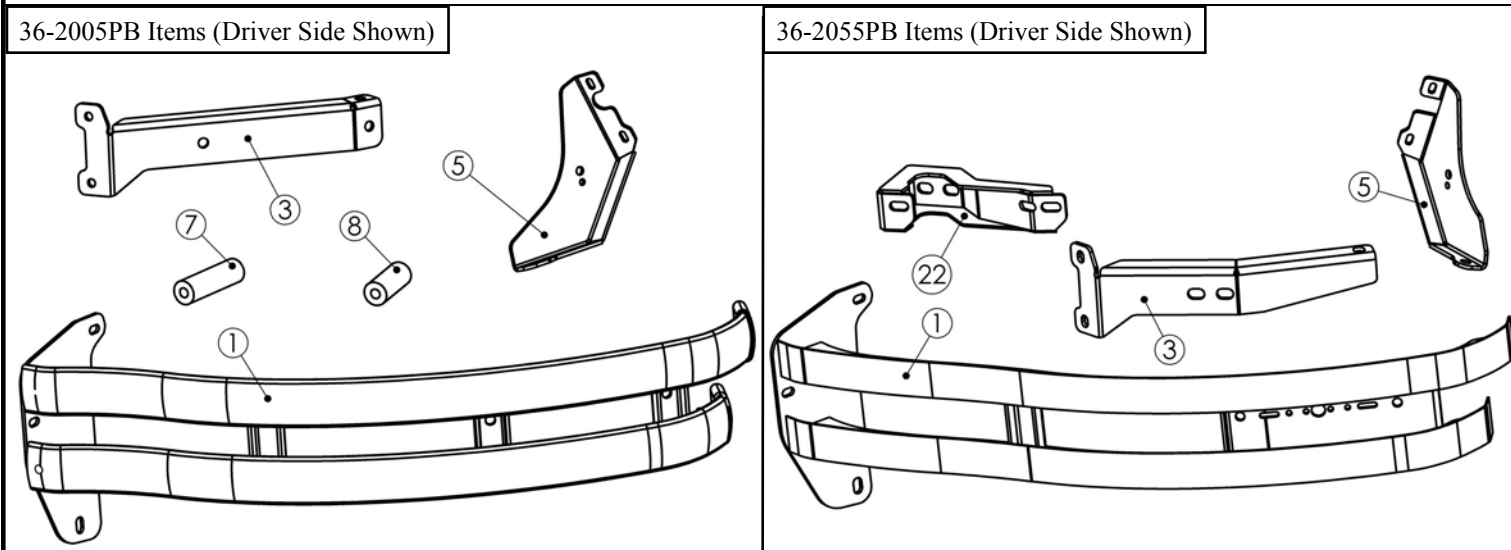

PROCEDURE

1. Remove contents from box, verify if all parts listed are present and free from damage.
Carefully read and understand all instructions before attempting installation.
Failure to identify damage before installation could lead to a rejection of any claim.
2. Remove the entire front grille and fascia (referred to as front clip) from the front of the vehicle. Follow the directions on I/S 75-36200 for the 36-2005 / 36-2055 push bar to accomplish this.
3. If they have not been previously installed; attach the push bar mounting brackets contained in the 36-2005 OR 36-2055 kit (refer to I/S 75-36200).
4. One side at a time remove the factory bolts from the ends of the steel bumper channel and re-use them to loosely attach the inner mounting brackets (items 3,4) (Figure 1).
5. Remove the factory M6 inner fender bolts and re-use them to loosely attach the inner support brackets (items 5,6) (Figure 2). Note: On certain vehicles the driver side the factory horn and bracket must be removed to accomplish this. Use the supplied M6 hardware to re-attach the horn and bracket to the holes in the inner support brackets.
6. Bolt the inner mounting bracket to the inner support bracket using the provided M12 flange bolt and nut. Note: The nut should be placed on the top of the bracket to allow for the socket head cap screws that hold the pit rails to the inner mounting brackets. Align and adjust brackets as necessary then tighten all bracket mounting hardware as follows: (M6) 6-8 ft-lbs., (M10) 30-35 ft-lbs., and (M12) 50-55 ft-lbs.

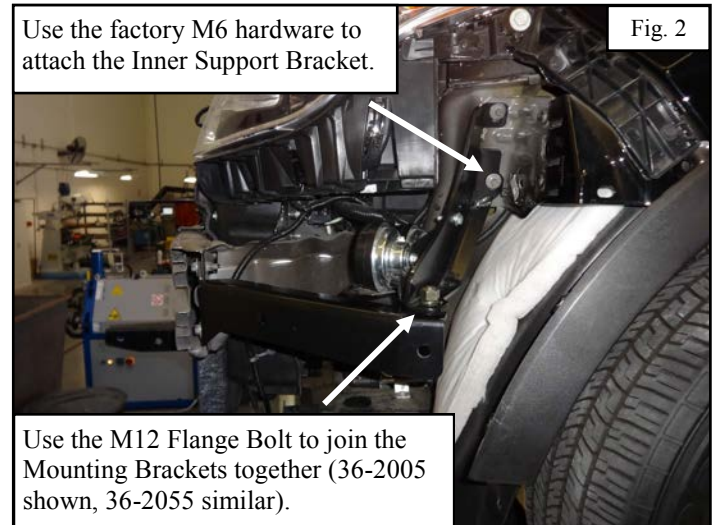
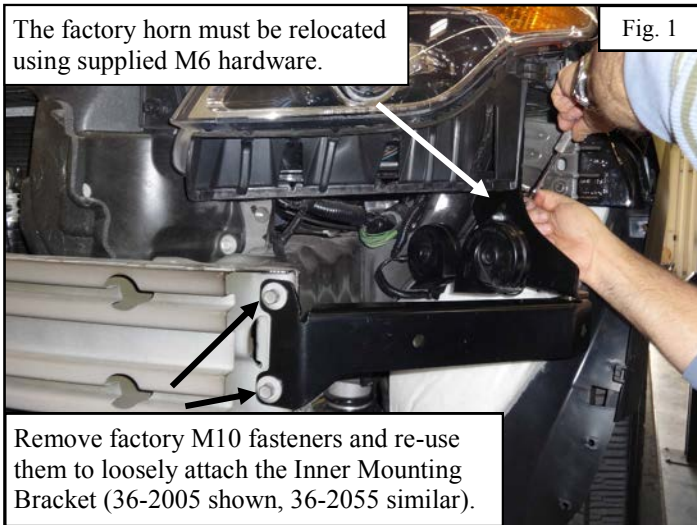

7. Snap the plastic front clip back on the vehicle, but do not attach the retaining screws that are in the fender well area.
8. Install the 36-2005 or 36-2055 push bar on the front of the vehicle per I/S 75-36200. Leave the mounting hardware loose as much of it will be re-used to mount the pit bar rails.
9. **For 36-2055 Only-** Trim the area on the plastic bumper cover using the provided cutout template, refer to Figure 3. In order to provide room for the pit bar brackets (items 22,23). Trim the cover as necessary to make sure the brackets fit. Once the hole cut out is properly sized, loosely install the mounting brackets using the supplied M12 hardware.
10. One side at a time attach the pit bar rails to the push bar using the push bar mounting hardware plus the supplied M10 button head bolts.
11. **For 36-2055 Only-** Loosely attach the pit bar rails to the pit bar brackets using the supplied M10 hardware.

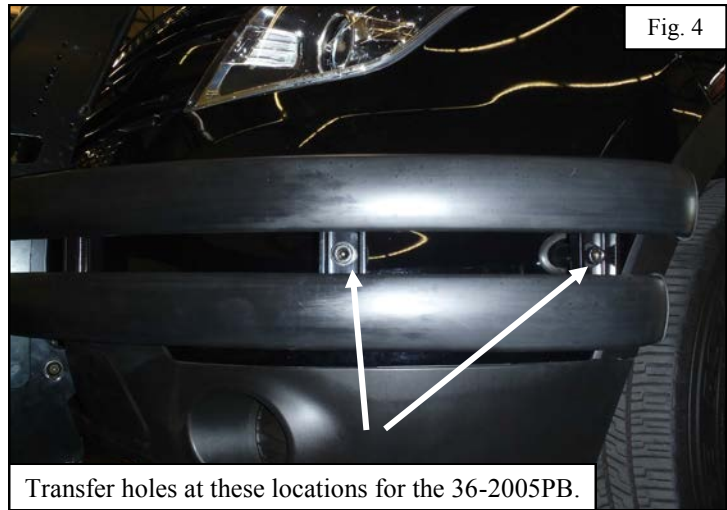

12. **For 36-2005 Only** - With the pit bar rails installed, use a 1/2" or 17/32" transfer punch placed through the mounting holes on the pit bar rails to mark drilling locations on the vehicle's front clip. Remove the pit bar rails then use a 1/4" drill bit to drill the marked locations.
13. **For 36-2005 Only** - Spread the inner fender plastic away from the front clip and reach through with a light. Look through the drilled 1/4" holes to verify that they are inline with the mounting holes on the inner mounting brackets.
14. **For 36-2005 Only** - Use a 1-1/2" hole saw to drill holes using the 1/4" pre-drilled holes as a guide. Note: Be aware of a plastic reinforcement piece on the backside of the front clip that may necessitate drilling the holes slightly high to clear it.
15. **For 36-2005 Only** - Deburr the drilled 1-1/2" holes and install the supplied rubber grommets.
16. **For 36-2005 Only** - Place the supplied spacers inside the drilled 1-1/2" holes. Note: The longer spacer goes toward the center portion on the vehicle. Loosely re-install the pit bar rails.
17. **For 36-2005 Only** - Place an M12 flat washer on each M12 socket head cap screw, then feed the hardware through the pit bar rail assembly, spacers and the inner mounting bracket.
18. **For 36-2005 Only** - Reach through the opening between the front clip and the plastic inner fender in order to thread an M12 flange nut on each of the M12 socket head cap screws (Figure 5).
19. **For 36-2005 Only** - Hold the nuts with a box end wrench while tightening the hardware from the front with an allen wrench.
20. Align and adjust the pit bars and push bar as necessary. Tighten all remaining hardware as follows: (M10) 30-35 ft-lbs., (M12) 50-55 ft-lbs. Install all remaining factory front clip hardware.



36-2005PB Exploded View

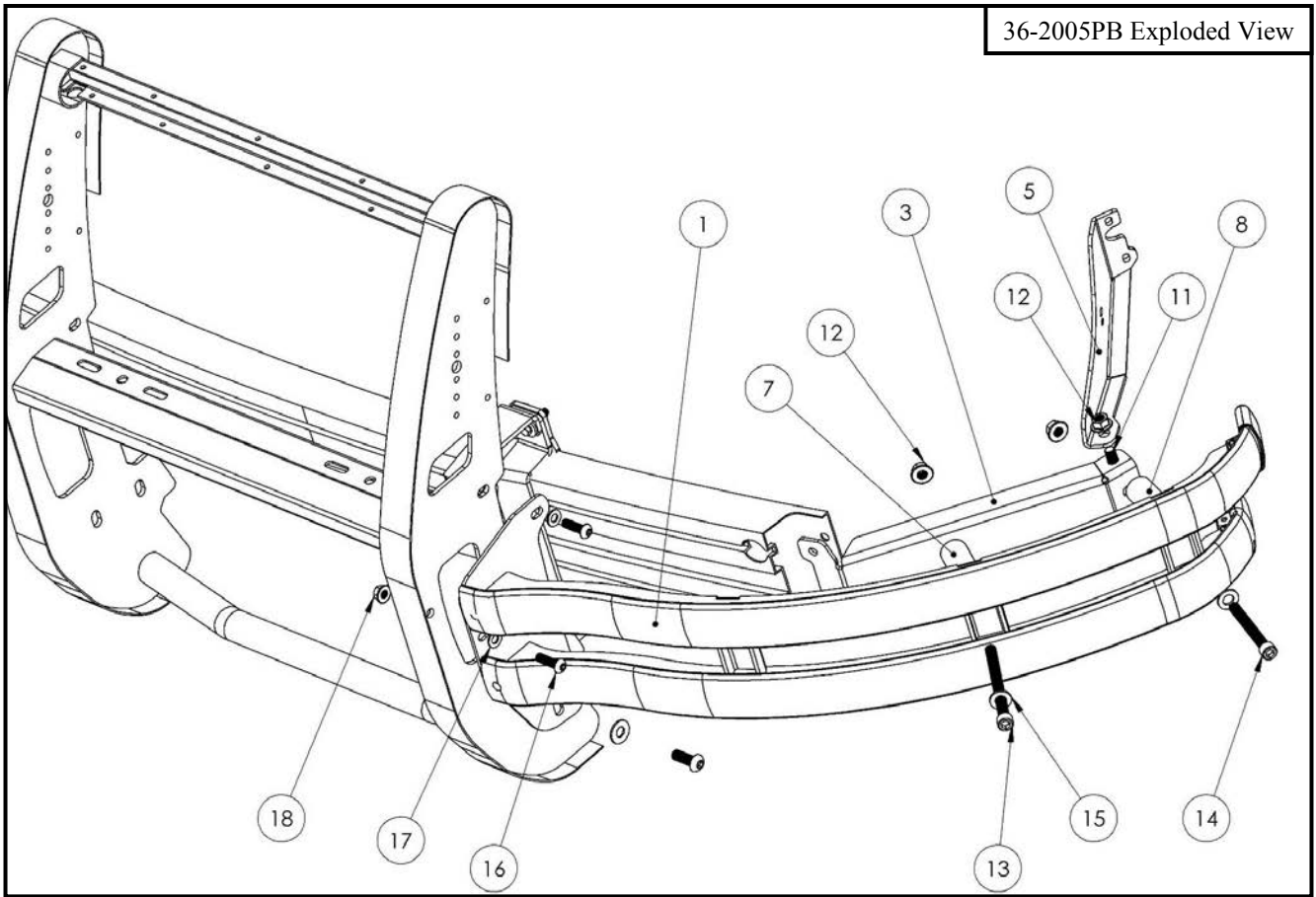

36-2055PB Exploded View

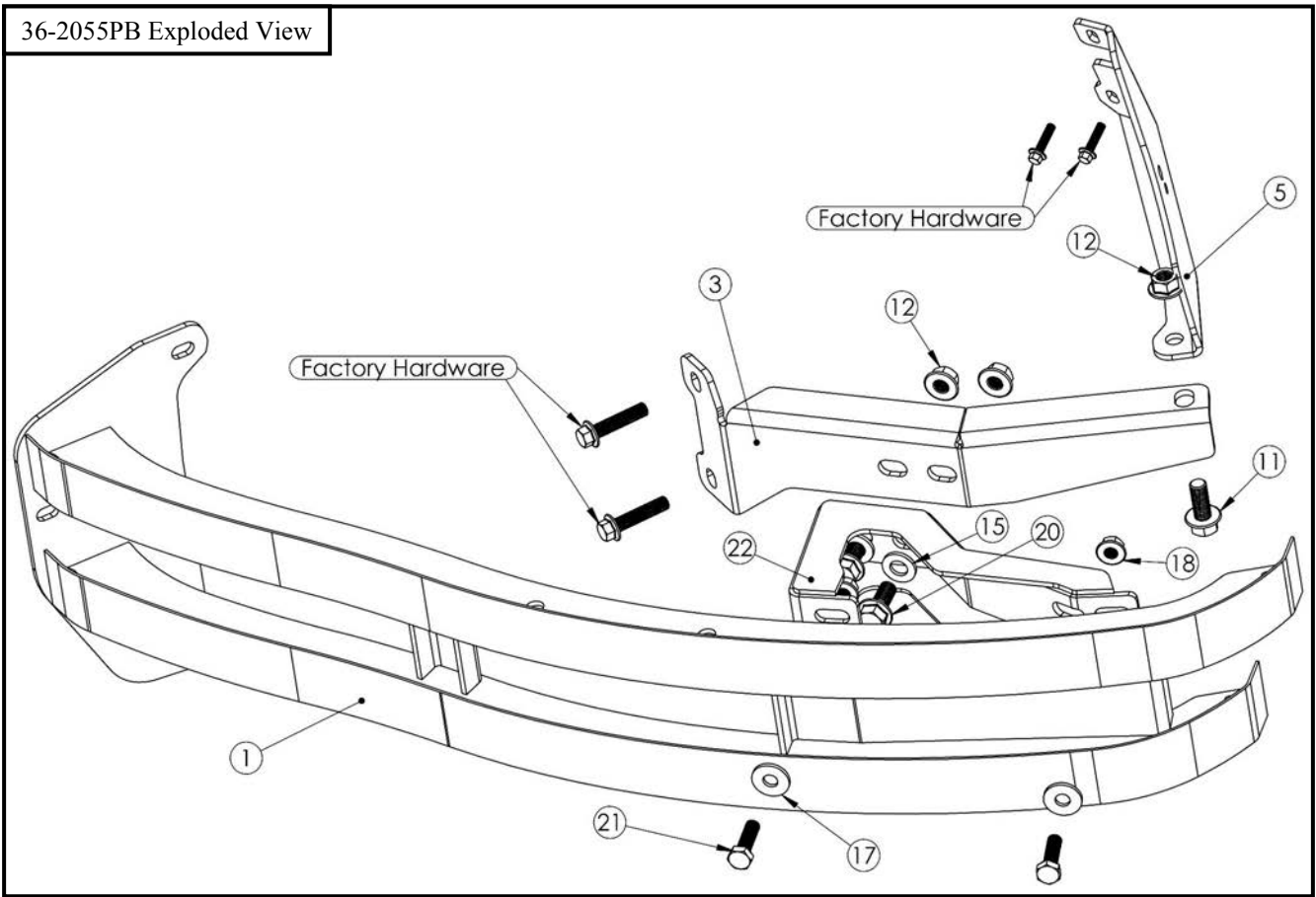

Westin

SIGNATURE OF QUALITY

AUTOMOTIVE PRODUCTS, INC.



WARNING



Failure to follow these instructions could lead to death, personal injury, and / or property damage.

FASTENERS:

All Westin supplied fasteners must be utilized and installed in accordance with the installation instructions and apply torque to the specifications as defined. **DOUBLE CHECK ALL FASTENERS BEFORE INITIAL USE, AND PERIODICALLY IN THE FUTURE TO ENSURE PROPER FUNCTION AND SAFETY.**

DRILLING:

Most Westin products do not require drilling for installation. If drilling is defined as required, use caution when drilling a vehicle. **FAILURE TO REVIEW AN AREA TO BE DRILLED MAY RESULT IN PERSONAL INJURY AND/OR INJURY TO OTHERS AS WELL AS VEHICLE DAMAGE.**

EYE PROTECTION:

ALWAYS WEAR SAFETY GLASSES OR GOGGLES DURING THE INSTALLATION PROCESS TO AVOID PERSONAL INJURY.

MAXIMUM TOWING/CARRYING CAPACITY:

The Westin Receiver Hitches will have a visible tow rating label affixed directly on the product. User should never exceed the vehicle manufacturers maximum tow and weight rating regardless of the capacity of the hitch. **FAILURE TO FOLLOW THESE GUIDELINES WILL VOID THE WESTIN WARRANTY AND MAY RESULT IN PERSONAL INJURY AND/OR INJURY TO OTHERS AS WELL AS VEHICLE DAMAGE.**

Westin.
SIGNATURE OF QUALITY