



AUTOMOTIVE PRODUCTS, INC.

INSTRUCTIONS

APPLICATION: 2011-UP CHEVY/GMC SILVERADO/SIERRA 2500/3500 HD
APP PART # 32-2320, 32-2325
BULL BAR

ITEM	QUANTITY	DESCRIPTION	TOOLS NEEDED
1	1	BULL BAR	18MM SOCKET
2,3	2	FRAME MOUNTING BRACKETS (2) DRIVERS SIDE, (3) PASSENGER SIDE	18MM WRENCH
4,5	2	BULL BAR MOUNTING BRACKETS (4) DRIVERS SIDE, (5) PASSENGER SIDE	9/16" SOCKET
6	4	M12 HEX HEAD BOLTS	9/16" WRENCH
7	8	M12 FLAT WASHERS	TORQUE WRENCH
8	4	M12 LOCK WASHERS	RATCHET
9	4	M12 HEX NUTS	7/32" ALLEN WRENCH
10	4	3/8" BUTTON HEAD BOLTS (STAINLESS)	
11	16	3/8" FLAT WASHERS (STAINLESS)	
12	8	3/8" LOCK WASHERS (STAINLESS)	
13	8	3/8" HEX NUTS (STAINLESS)	
14	4	3/8" HEX HEAD BOLTS (STAINLESS)	

1. Remove all contents from box, verify all parts listed are present and free from damage. Carefully read and understand all instructions before attempting installation. Anti seize must be used on all stainless steel hardware to prevent from galling.
2. Starting from underneath the vehicle locate the two factory bolts attaching the factory tow hook to the frame. Remove the factory hardware and the tow hooks. NOTE : the factory tow hooks will not be re-used. Repeat this step for the passenger side. FIG 1
3. Locate the drivers side frame mounting bracket and place it through the tow hook opening in the lower valance. Attach the drivers side frame mounting bracket to the same locations the tow hook hardware was removed. Attach the bracket using (2) M12 hex head bolts, (4) M12 flat washers (2) M12 lock washers, and (2) M12 hex nuts. Repeat this step for the passenger side. Do not fully tighten at this time. FIG 2
4. Locate the drivers side bull bar mounting bracket and align it to the previously installed frame bracket. Attach it to the frame bracket using (2) 3/8" hex head bolts (stainless), (4) 3/8" flat washers (stainless), (2) 3/8" lock washers (stainless), and (2) 3/8" hex nuts (stainless). Repeat this step for the passenger side Do not fully tighten at this time. FIG 3
5. With assistance take the bull bar and align it to the outside of the previously installed bull bar mounting brackets. Attach the bull bar using (4) 3/8" (stainless) button head bolts, (8) 3/8" flat washers (stainless), (4) 3/8" lock washers (stainless), and (4) 3/8" hex nuts. Do not fully tighten at this time. FIG 4
6. Align and adjust the bull bar as needed then tighten all hardware at this time. Torque all M12 hardware to 55 ft lbs, and 3/8" hardware to 20-25 ft lbs.



CARE INSTRUCTIONS

- REGULAR WAXING IS RECOMMENDED. DO NOT USE ANY TYPE OF POLISH OR WAX THAT MAY CONTAIN ABRASIVES
- STAINLESS STEEL PRODUCTS CAN BE CLEANED WITH MILD SOAP AND WATER. STAINLESS STEEL POLISH SHOULD BE USED TO POLISH SMALL SCRATCHES.
- GLOSS BLACK FINISHES SHOULD BE CLEANED WITH MILD SOAP AND WATER

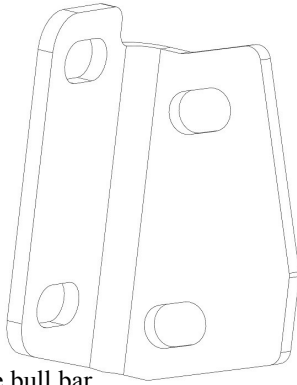

Passenger side bull bar mounting bracket

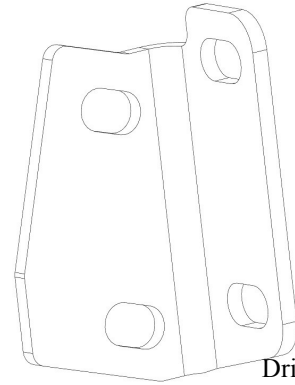

Drivers side bull bar mounting bracket

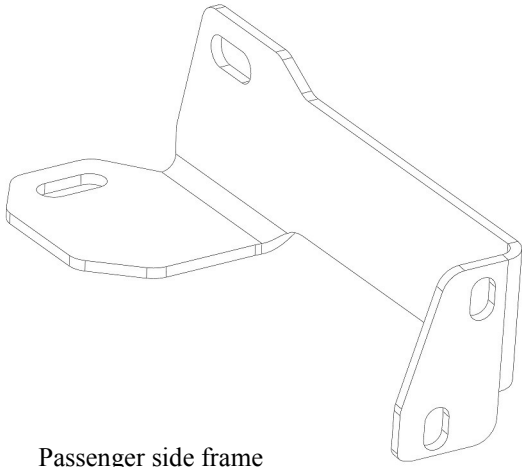

Passenger side frame mounting bracket

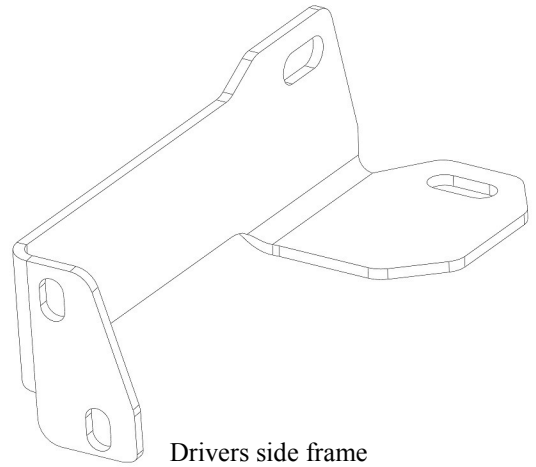

Drivers side frame mounting bracket

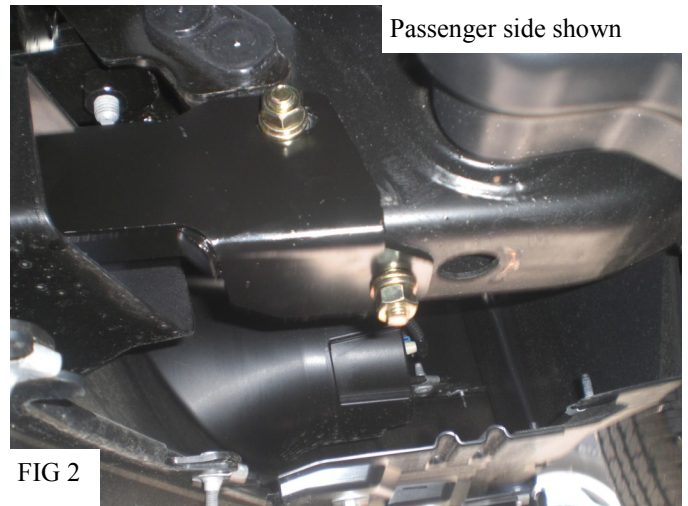
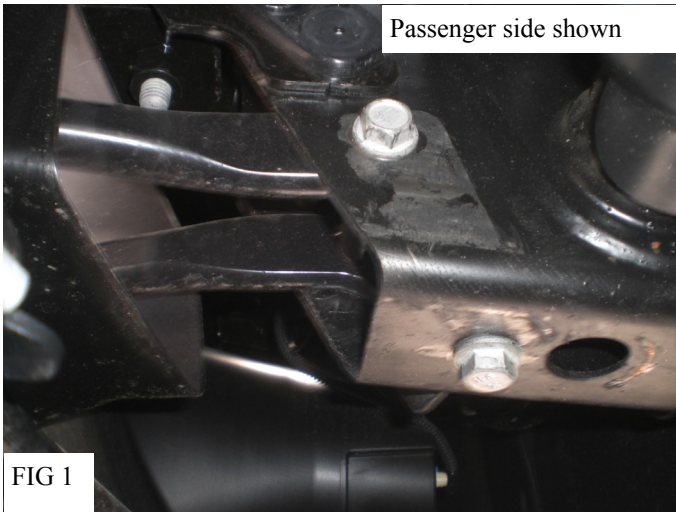

Drivers side shown

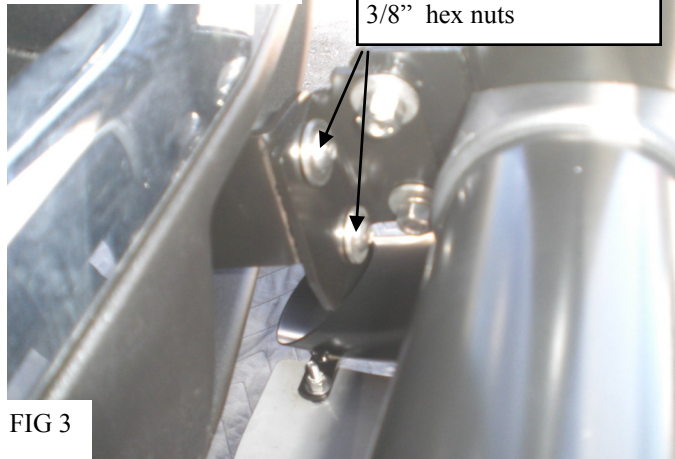

(2) 3/8" hex head bolts,
(4) 3/8" flat washers, (2)
3/8" lock washers, (2)
3/8" hex nuts

FIG 3

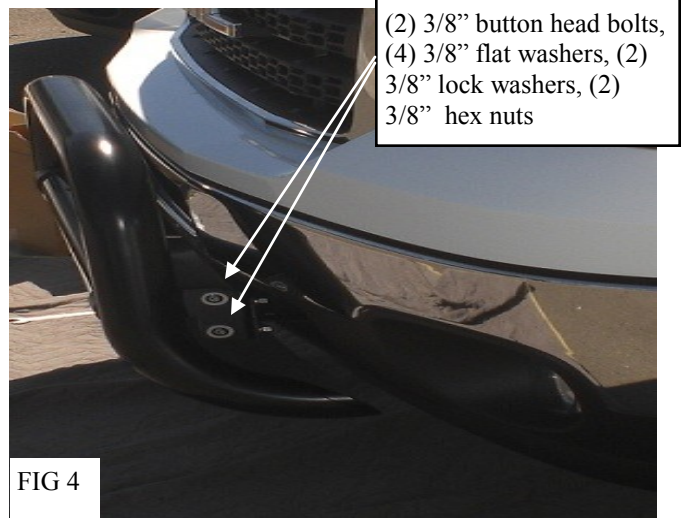

(2) 3/8" button head bolts,
(4) 3/8" flat washers, (2)
3/8" lock washers, (2)
3/8" hex nuts

FIG 4



INSTALLATION COMPLETE



Learn more about grille guards and bull bars we have.