



INSTALLATION INSTRUCTIONS

2.5" CONTOUR BAR

APPLICATION:
2011-2015 Dodge Durango

AUTOMOTIVE PRODUCTS,

PART NUMBER:
32-21230, 32-21235

CONTENT			
ITEM	QUANTITY	DESCRIPTION	TOOLS NEEDED
1	1	CONTOUR BAR ASSEMBLY	RATCHET
2	1	PASSENGER SIDE MOUNTING BRACKET	TORQUE WRENCH
3	1	DRIVER SIDE MOUNTING BRACKET	10MM SOCKET
4	2	M10 HEX HEAD BOLT (YELLOW ZINC)	16MM SOCKET
5	2	M10 LOCK WASHER (YELLOW ZINC)	19MM SOCKET
6	2	M10 FLAT WASHER (YELLOW ZINC)	SOCKET EXT.
7	2	M12 HEX HEAD BOLT (YELLOW ZINC)	
8	2	M12 LOCK WASHER (YELLOW ZINC)	
9	2	M12 LARGE FLAT WASHER (YELLOW ZINC)	

ANTI-SEIZE LUBRICANT MUST BE USED ON ALL STAINLESS STEEL FASTENERS TO PREVENT THREAD DAMAGE AND GALLING

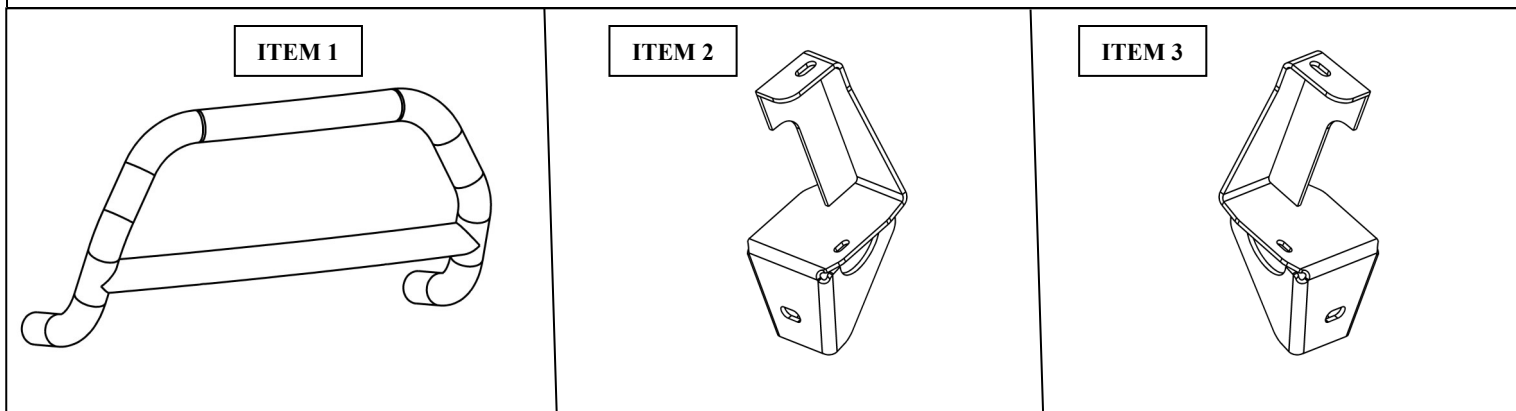

PROCEDURE

1. Remove contents from box, verify if all parts listed are present and free from damage.
Carefully read and understand all instructions before attempting installation.
Failure to identify damage before installation could lead to a rejection of any claim.



1. Remove the splash guard underneath the vehicle to find the general area of the mounting location. Check the alignment of your bracket with the mounting location so you know the general area to trim. See **Figure 1** and **2**.

Figure 1

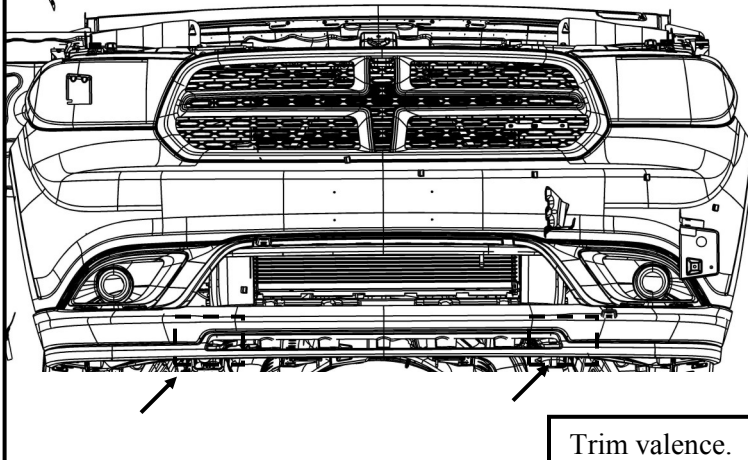
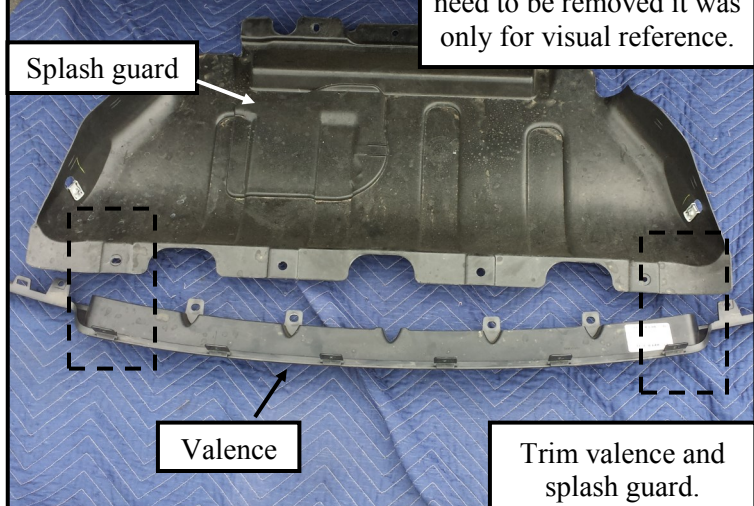

Figure 2



2. First loosely install the passenger side mounting bracket at its upper location to the threaded hole on the vehicles frame with the supplied M10 hardware, repeat for drivers side. See **Figure 3**.
3. After the bracket has been located it will align where a factory M6 bolt was used to hold the splash guard up. Loosely install the mounting bracket with the factory M6 bolt. See **Figure 3**.
4. Loosely install the contour bar to the previously install mounting brackets with the supplied M12 hardware. See **Figure 4**.

Figure 3

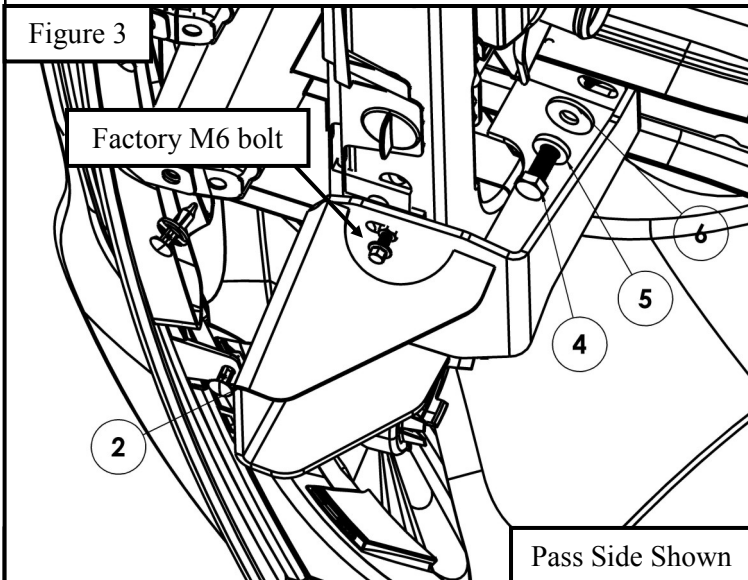
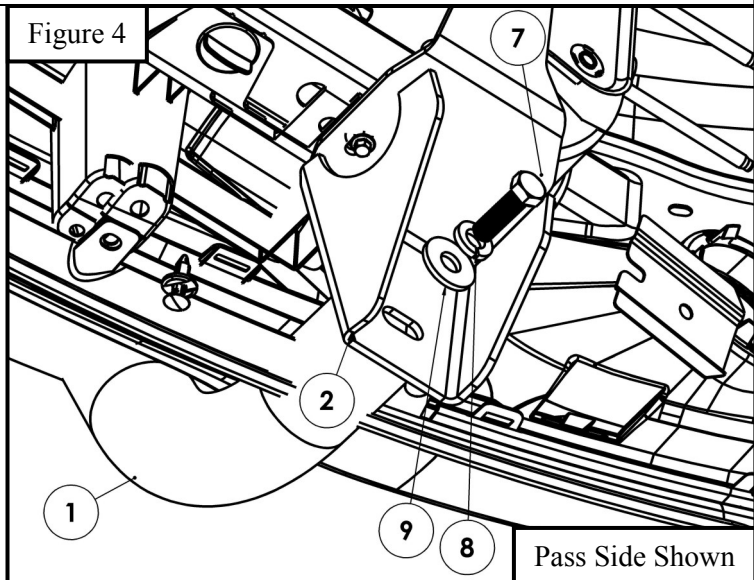

Figure 4



5. Align bar and brackets to desired positioning then torque and tighten all: M6 hardware to 12 ft-lbs, M10 hardware to 30 ft-lbs, and M12 hardware to 65 ft-lbs.

INSTALLATION COMPLETED



Care Instructions

- REGULAR WAXING IS RECOMMENDED. DO NOT USE ANY TYPE OF POLISH OR WAX THAT MAY CONTAIN ABRASIVES.
- STAINLESS STEEL PRODUCTS CAN BE CLEANED WITH MILD SOAP AND WATER. STAINLESS STEEL POLISH SHOULD BE USED TO POLISH SMALL SCRATCHES..
- GLOSS BLACK FINISHES SHOULD BE CLEANED WITH MILD SOAP AND WATER.

Westin
SIGNATURE OF QUALITY

OPTIONAL LIGHT MOUNT TABS

ITEM	QUANTITY	DESCRIPTION	TOOLS NEEDED
10	2	LIGHT MOUNT BRACKET TABS	HEX KEY TOOL (INCLUDED)
11	2	M10 BUTTON HEAD CAP SCREW	
12	2	M10 TOOTHED LOCK WASHER	
13	2	M10 FLAT WASHER	
14	1	ADHESIVE FOAM TAPE	

PROCEDURE

1. Remove contents from box, verify if all parts listed are present and free from damage.
Carefully read and understand all instructions before attempting installation.

Failure to identify damage before installation could lead to a rejection of any claim.

2. Apply foam tape to front and back of the tab facing where it mounts to the tube. **See Figure 5.**
3. Using the supplied hex key tool, button head cap screws, lock washers, and flat washers, attach the bracket tabs to the threaded inserts in the bottom of the cross tube. **See Figure 6.**

Figure 5

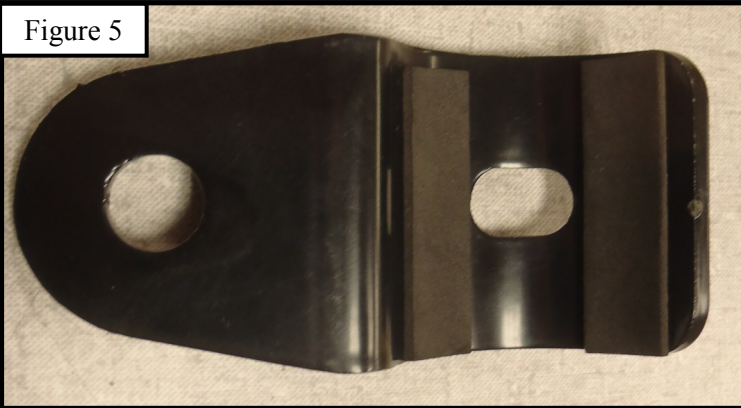

Figure 6

