



**VAN STORAGE SOLUTIONS**  
FOR THE WAY YOU WORK™

# INSTALLATION MANUAL

## MOUNTING CHANNEL KIT, 85 in (2085-0-01)

**ATTENTION: PLEASE READ AND UNDERSTAND ALL INSTRUCTIONS AND WARNINGS BEFORE ASSEMBLING, INSTALLING OR USING THIS PRODUCT.**

### TOOLS REQUIRED

- RTV Automotive/ Exterior sealant (not included)
- Thread Lock Compound (not included)
- 4 mm HEX KEY (for M6 mounting bolts)
- 5 mm HEX KEY (for M8 mounting bolts)
- 13 mm Wrench/ Socket (for M8 hex head bolts)
- 1/2 in Wrench
- 9/16 in Wrench
- Drill, air or electric, with 1/8 in bit, 7/16 in or 11mm bit
- Tape measure
- Marker
- Saw (FOR SHORT WHEELBASE FORD TRANSIT CONNECT)

### CAUTION

Be safe - always wear protective eyewear to keep debris out of your eyes when installing WEATHER GUARD® Van Products.

### PARTS LIST



14X 5/16" WASHER



12X M8X20MM BOLT



12X M8 SQUARE NUT



10X M8 BLIND FASTENER

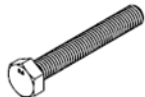

1X M8X55MM HEX



1X BLIND FASTENER  
INSTALL TOOL



6X M6X18MM BOLT



6X M6 WASHER

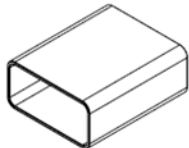

4X RED CAP

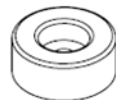

2X 5/8" BUMPER



2X 1/4" FOAM TAPE



2X 5/16"X1-1/4" BOLT



2X 5/16" NYLON LOCK NUT



2X MOUNTING CHANNEL

**ATTENTION: PLEASE READ AND UNDERSTAND ALL INSTRUCTIONS AND WARNINGS  
BEFORE ASSEMBLING, INSTALLING OR USING THIS PRODUCT.**

## **INSTALLATION INSTRUCTIONS**

### **GENERAL INSTRUCTIONS:**

The mounting channel kit includes mounting channels and hardware to attach the channels to the roof of a compact van using mounting holes or weld nuts provided by the OEM van manufacturer.

- STEP 1** Position mounting channels on roof of van aligning the holes and slots with OEM mounting points.
- STEP 2** Apply RTV sealant (not included) to the van roof around the mounting points to prevent water from leaking into the vehicle.
- STEP 3** Attach red cap to ends of mounting rails.
- STEP 4** Apply thread lock compound (not included) to mounting bolts.
- STEP 5** Attach the mounting channels to the van using the washers and mounting bolts provided.

### **VEHICLE SPECIFIC INSTALLATION NOTES:**

**FORD TRANSIT CONNECT:** On MY 2014 and newer vans, Ford provides mounting holes but not weld nuts in the 2014 and later Transit Connect. First, remove the plastic caps plugging the mounting holes. Next, enlarge the mounting holes using a 7/6" or 11 mm drill to fit the blind fasteners. Follow the BLIND FASTENER INSTALLATION INSTRUCTIONS on the next page to mount the blind fasteners. Be careful during installation not to damage any wiring or safety equipment that may be located inside the roof of the van.

Position the rails on the roof. On short wheel-base vans, the mounting channels need to be cut shorter.

Mark the desired length, cut with the saw, and attach the red cap to the cut end of the channel.

Use the M8 bolts provided to attach the mounting channels to the weld nuts in the van roof.

Tighten bolts to 17 ft-lbs.

**RAM PROMASTER CITY:** Follow the General Instructions above.

Use the M8 bolts provided to attach the mounting channels to the weld nuts in the van roof.

Tighten bolts to 17 ft-lbs..

**CHEVY CITY EXPRESS/ NISSAN NV200:** Follow the General Instructions above. Use the M6 bolts provided to attach the mounting channels to the weld nuts in the van roof. Because of the roof design, there is a small gap between the roof and the front of the mounting channel. Attach the 1/4 in Foam Tape to the underside of the channel at the front of the van. Tighten bolts to 8 ft-lbs.

**NISSAN NV HIGH ROOF:** Because of the roof design, there is a small gap between the roof and the mounting channel at the rear of the van. Weather Guard does not recommend installing blind fasteners into the NV roof. Instead, to provide a solid support for the front of the mounting channel, attach the Bumpers to the underside of the channel using two each of the 5/16-18 x 1-1/4 in mounting bolt, the 5/16 in washer, and the 5/16-18 lock nuts. Tighten to 10 ft-lbs.

The Nissan NV provides raised mounting brackets for roof-rack mounting. Position the mounting channels over the brackets and use the M8 bolts and M8 square nuts to attach the channels to the brackets. Tighten bolts to 17 ft-lbs.

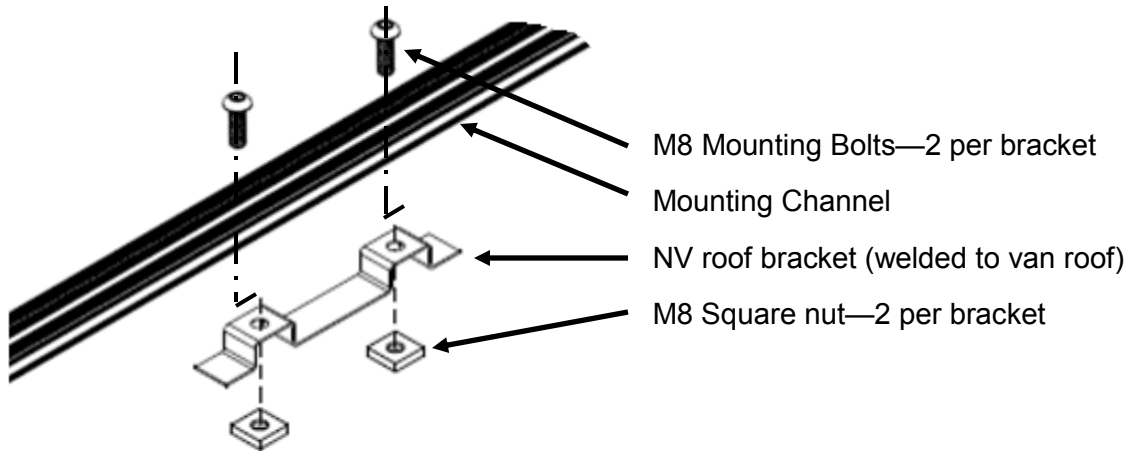

### OLDER VANS

The mounting channel kits are designed for MY2014 and later compact vans, but they can also be used on older vans such as the the 2010-2013 Ford Transit Connect or the RAM C/V. These vehicles do not include convenient roof mounting points. Use the M8 bolts and blind fasteners. Mark your mounting positions using the mounting channel as a guide. Drill pilot holes using a 1/8" bit and then enlarge them using a 7/6" or 11 mm bit to fit the blind fasteners. Follow the blind fastener installation instruction to mount the blind fasteners. Be careful during installation not to damage wiring or airbags that may be located inside the roof of the van.

## Installing Blind Fasteners

Before installing blind fasteners, verify the location of wiring, air-bags, sense wires, etc. so you don't accidentally damage something important.

Slip a washer on the M8 x 55 mm bolt, and pass them through the 9/16 wrench and installation tool as show at right. Place a drop of oil on the M8 bolt before threading on the blind fastener.

Place the blind fastener through the hole and use the 13 mm wrench or socket to tighten the bolt until the blind fastener is fully seated.

As the blind fastener "bulbs-out" it will get easier to turn until it bottoms out and "sets". Make sure that the blind fastener and installation tool do not turn during installation.

After the blind fastener is set remove the M8 x 55 mm bolt and install the M8 mounting bolt.

