

ASSEMBLY AND INSTALLATION INSTRUCTIONS

All-Purpose Rack - Model 220 & 221

(For Astro and Safari)

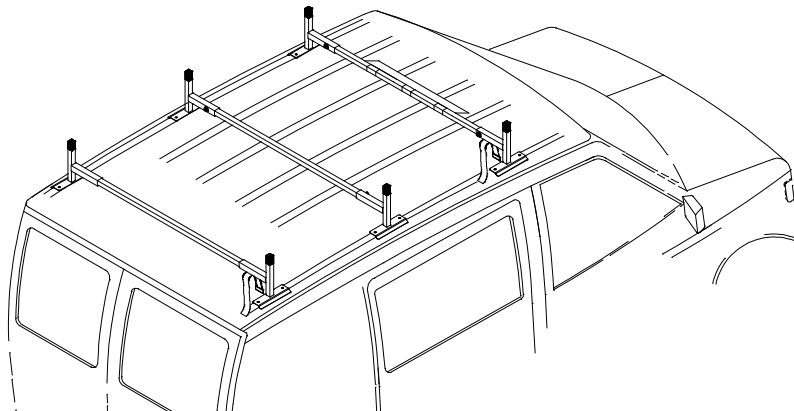

Approx. Installation and Ass'y. Time
Model 220 = 1 hr. Per Unit
Model 221 = 0.4 hr. Per Unit
 Depending On Van Equipment
 Installation Experience

The distinctive, trademarked
RED TIPS are your assurance of
WEATHER GUARD® Equipment
 quality.

IMPORTANT BEFORE YOU BEGIN

Read these instructions and warnings completely before installation.

BOLT KITS

Each model has an individual bolt kit provided. Check this bolt kit to be sure the following parts are included:

Model 220 #32-0096	Model 221 #32-0097	Description
6	4	1/4" Fender Washer
2	0	1/4" Lock Washer
2	0	1/4-20 Blind Fastener
1	0	1/4-20 x 2-1/4" Bolt, (Black Oxide)
6	4	1/4-20 Nylon Lock Nut
8	4	1/4-20 x 1-1/4" Hex Head Bolt
1	0	Installation Tool
4	2	3/8-16 x 3/4" Bolt, Hex Hd., Thd. Cut
6	0	#8-18 x 1/2" Tek Screw

⚠ WARNING

This product is only intended for, and only safe for, transporting ladders, lumber, pipe and other similar materials. It is the responsibility of the user to secure these materials to the rack before transporting. Any modifications made to this product, or use of this product for any other purpose than its intended use, could create a hazardous condition that can cause serious personal injury or property damage.

⚠ CAUTION

Load should be approximately centered front to rear. Failure to do this will cause damage to the vehicle roof. Long loads that extend out the rear of the vehicle will prevent the rear hatch from fully opening and cause damage if attempted.

PARTS LIST

Model 220	Model 221	Description
1	0	Air Foil
2	1	Crossmember
1	0	Drivers Side Front Stand
1	0	Passengers Side Front Stand
1	0	Drivers Side Rear Stand
1	0	Passengers Side Rear Stand
0	2	Center Stand
4	2	Mounting Pad
1	0	Tube, E-6000 Sealant
2	0	Ladder Straps

TOOLS REQUIRED

- Electric Drill
- 1/8", 9/32" & 13-32" Drill Bits
- 9/16" Wrench
- 7/16" Wrench (2)
- Ruler
- 1/4" Nut Driver Bit (See Figure 4) or 1/4" Socket

Rev. A 7/04 Part No. 24-0162



INSTALLATION PROCEDURE USING BLIND FASTENERS

Place a drop of oil on the black oxide bolt before assembling as shown on right. Place the Blind Fastener in the hole and use a 1/2" or 7/16" wrench to tighten black hex bolt until the blind fastener is fully seated. When setting black hex bolt, it will start out hard. As the Blind Fastener "bulbs" out it will get easier, until it bottoms out or sets. Make sure the Blind Fastener and Installation Tool do not turn during installation.

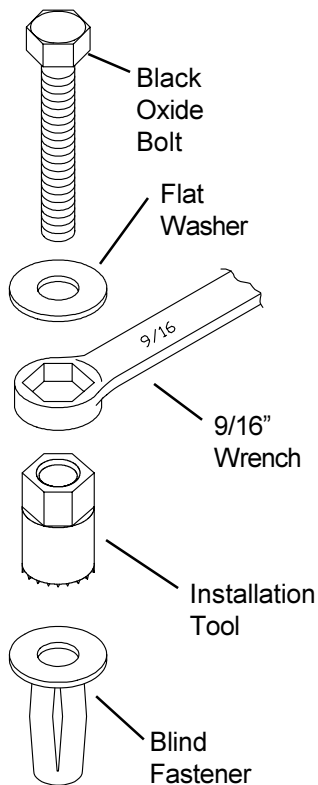

⚠ WARNING

Ladders must be secured per ANSI standard A142.2-1990 paragraph 8.4.4. Ladder damage will occur from road shock and vehicle vibration if the ladder is not properly secured to the ladder rack. Bouncing and side to side motion of a improperly secured ladder will cause wear and weaken the ladder. Using a damaged ladder could lead to a structural collapse and could result in a serious injury or death.

WEATHER GUARD® PRODUCT REFINISHING PROCEDURES

All WEATHER GUARD® products are finished with a polyester powdered coating, and it is important to follow these procedures to get proper adhesion. As Knaack Manufacturing Co. cannot control the finishing of the products, the warranty for WEATHER GUARD® products on paint is not applicable on refinished products.

1. Sand the surface to be painted with 180-200 grit sand paper to rough up the surface. This should be followed by wet sanding with a 400 grit wet or dry paper.
2. Wipe down the sanded surface with ketone based thinner. This removes the dust and softens the powder coating for better paint adhesion.
3. Wipe sanded area with a tack rag to remove loose dust and particles before painting.

NOTE: Do not use a lacquer over the powdered coating.

-NOTICE-

Any modification or unintended use of this product shall immediately void all manufacturers warranties. Manufacturer disclaims all liability for injuries to persons or property resulting from any modification to, or unintended use of this product.