



VAN STORAGE SOLUTIONS

FOR THE WAY YOU WORK™

INSTALLATION MANUAL

Bulkhead

Model Number 96141-3-01 and 96142-3-01

ATTENTION: PLEASE READ AND UNDERSTAND ALL INSTRUCTIONS AND WARNINGS BEFORE ASSEMBLING, INSTALLING OR USING THIS PRODUCT.

! PLAN YOUR VAN (TIPS FOR FASTER INSTALLATION)

- Installing your ProMaster bulkhead is very clear cut following these instructions.
- Before cutting or drilling in the floor, verify the location of you gas tank, fuel lines and electrical cables so you don't accidentally cut something important.
- When mounting to the floor, make sure that the blind fasteners go into the sheet-metal floor and not the composite floor. A hole saw will give you a nice, clean edge. Always wear eye protection when drilling or cutting.
- When mounting to the B-pillar, you'll need to cut through the plastic trim. A hole saw will give you a nice, clean edge. Use the 1/2" spacers to ensure a solid mount to the van.
- Your ProMaster van bulkhead can be up-graded with a swing-door conversion kit, 96901-3-01. If you think you might want to change to it in the future, put an extra nut between the driver's side panel and the center panel to allow enough space.

INSTALLATION TIME

Approximate installation time: 60 minutes per unit depending on van equipment installation experience.

TOOLS REQUIRED

- Electric Drill
- Electric Drill-driver or impact wrench
- Pencil or Marker
- Hammer
- Center Punch
- 1" Hole Saw
- Hack saw blade or sharp knife
- 7/16" and 1/2" Driver Bits and/or Sockets
- Drill Bits: 1/8", 3/8", 1/2", 13/32"
- Ratchet Drive for your sockets
- Level
- Carpenter's Square
- Open End Wrenches: 7/16", 1/2", 9/16"

BOLT KIT

DESCRIPTION	QTY
1/4-20 BLIND FASTENER	6
1/4-20 X5/8" HEX HEAD BOLT	15
1/4-20 NYLON LOCK NUT	24
5/16" FLAT WASHER	8
5/16-18 X2" HEX HEAD BOLT	4
1/4" FLAT WASHER	44
5/16-18 BLIND FASTENER	4
5/16" LOCK WASHER	4
5/16" FENDER WASHER	4
3/8" FLOOR MOUNTING SPACER	8
1/2" FLOOR MOUNTING SPACER	6
1/4-20x5/8 CARRIAGE BOLT	8
BLIND FASTENER INSTALL TOOL	1
1/4-20 x 2-1/4" HEX HEAD BOLT	1
5/16-18 x 2-1/4 HEX HEAD BOLT	1
1/4-20 x 1-1/4 HEX WSHR HD BOLT	6
SCREW, 1/4-14x3/4 DRILL	4
NUT, LOCK 5/16-18 NYLON	4

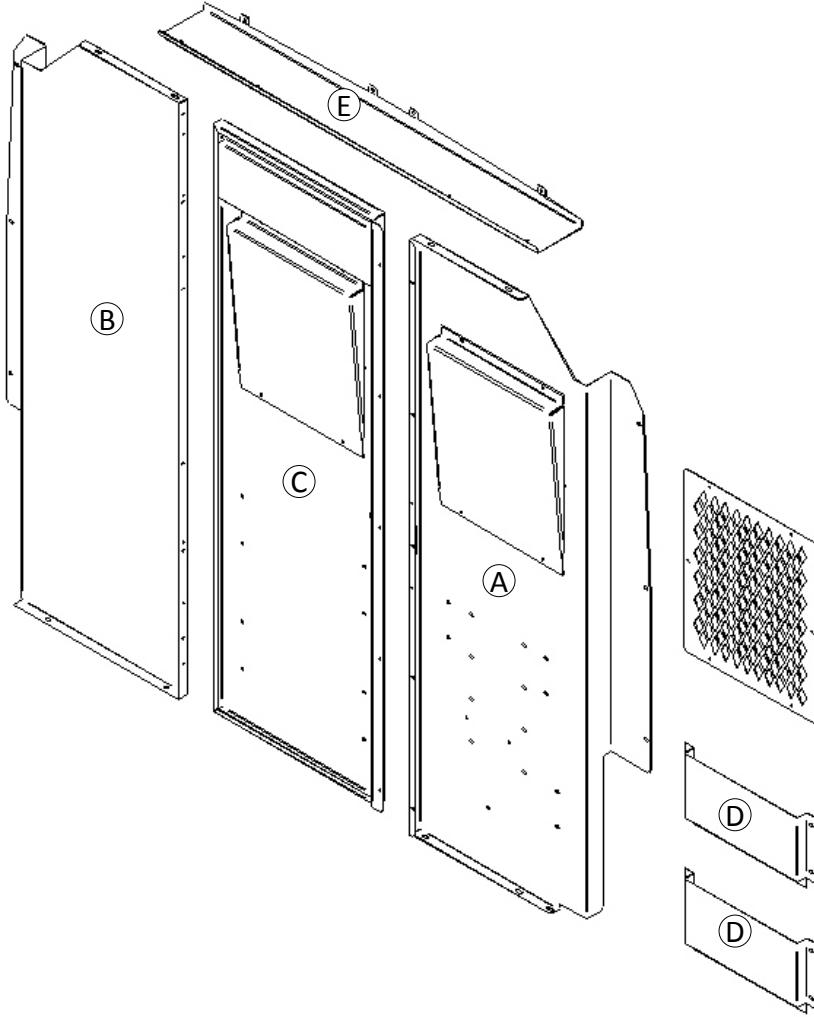

PARTS LIST		
	Qty.	Description
A	1	Passenger Side Panel
B	1	Driver Side Panel
C	1	Center Panel
D	2	Door Pockets
E	1	High Roof Header Panel
	1	Bolt Kit – Part #32-0198

Bulkhead model 96141-3-01 has two clear polycarbonate windows mounted to panels A and C.

Bulkhead model 96142-3-01 has two diamond mesh screens mounted to panels A and C.

Available accessories:
 Solid panel kit 96902-3-01
 Hinge kit 96901-3-01

ASSEMBLY INSTRUCTIONS

STEP 1. Assemble the Door Pockets to either the driver's side or cargo side of the Center Panel using eight (8) 1/4-20 x 5/8" Carriage Bolts, 1/4-20 Nylon Lock Nuts and 1/4" Flat Washers.

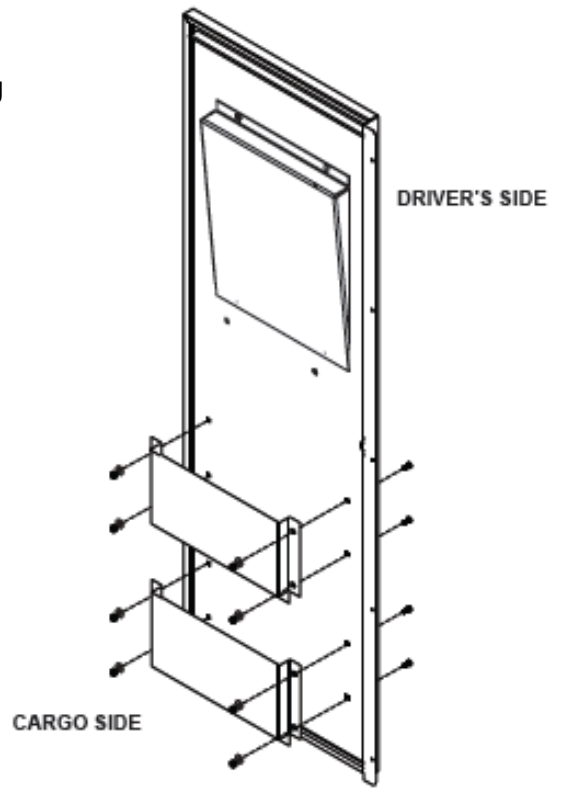

ASSEMBLY INSTRUCTIONS

STEP 2. Attach Driver Side Panel to Center Panel with both panels flush to the bottom using six (6) $\frac{1}{4}$ -20 x $\frac{5}{8}$ " hex head bolts, $\frac{1}{4}$ " flat washers, and $\frac{1}{4}$ -20 lock nuts.

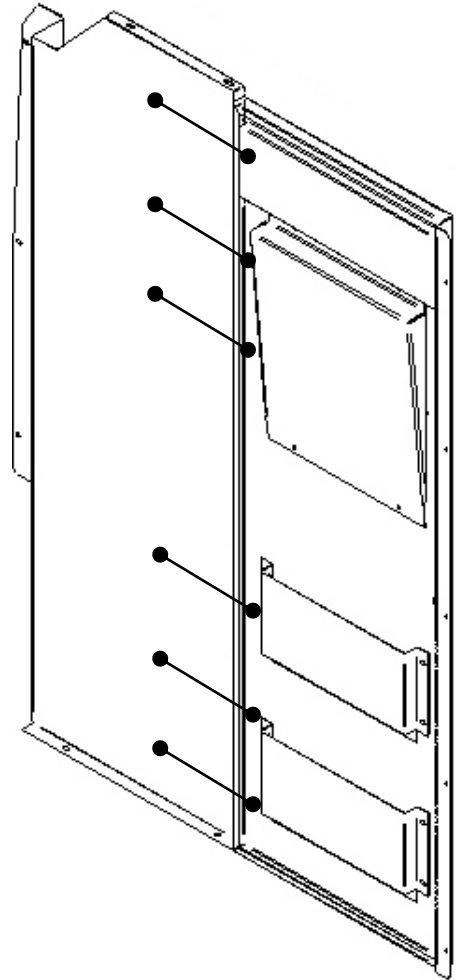
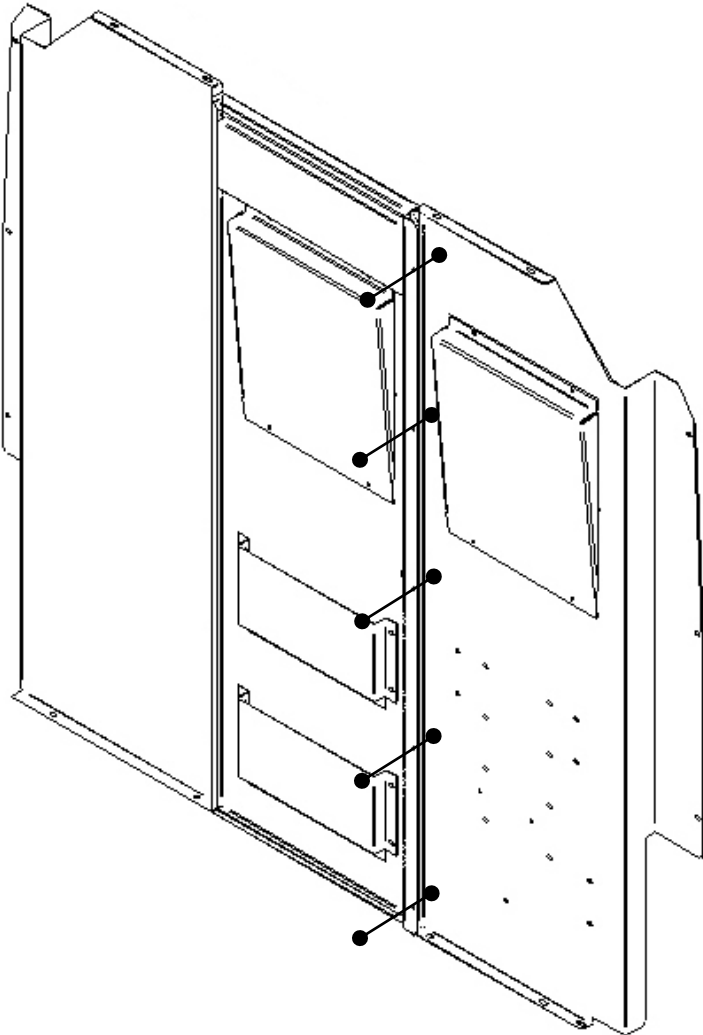

STEP 3. Attach Passenger Side Panel to Center Panel with both panels flush to the bottom using five (5) $\frac{1}{4}$ -20 x $\frac{5}{8}$ " hex head bolts, $\frac{1}{4}$ " flat washers, and $\frac{1}{4}$ -20 lock nuts.

DO NOT FULLY TIGHTEN FASTENERS AT THIS TIME, PARTS MUST STILL MOVE IN SLOTS.

NOTE: Not all mounting holes will be used on either of the vertical sides of the Center Panel. Extra mounting holes are for the swing door option available for this Bulkhead.

INSTALLATION INSTRUCTIONS

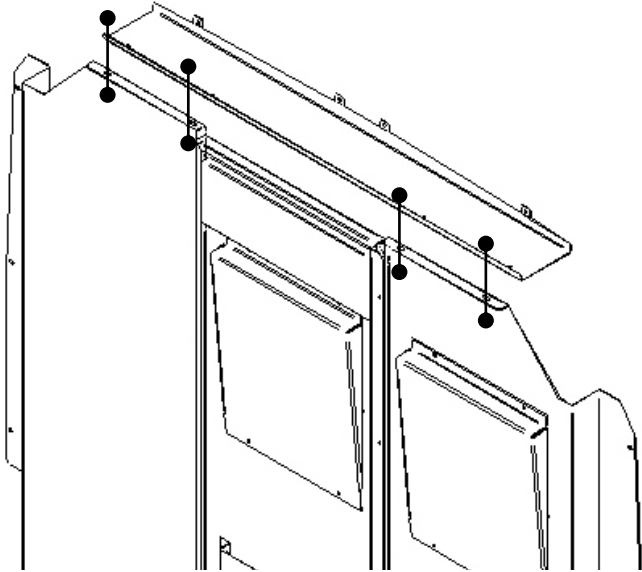

STEP 5. Attach the Header Support (Same panel for either Standard or High Roof vans.) to the Bulkhead using four (4) 1/4-20 x 5/8" Hex Head Bolts, eight (8) 1/4" Flat Washers and four (4) 1/4-20 Nylon Lock Nuts.

DO NOT FULLY TIGHTEN FASTENERS AT THIS TIME, PARTS MUST STILL MOVE IN SLOTS.

STEP 5. Place the Bulkhead against the B-Pillar trim. Using a center punch, mark the four Bulkhead bottom mounting holes on the floor of the van. Ensure the hole is located on the topside of the floor rib. Move the Bulkhead out of the way. Drill a pilot hole with an 1/8" drill bit, then re-drill the hole with a 3/8" drill bit. Floor Mounting Spacers are **required**. If there is a plywood floor in the van cut the wood floor around the 3/8" holes with a 1" hole saw, allowing Floor Mounting Spacers to rest against the metal floor. **DO NOT DRILL THROUGH THE VAN FLOOR WITH THE HOLE SAW.** 5/16" Lock Washers have been provided for bulkhead mounting.

NOTE: Four (4) Blind Fasteners are provided for mounting the bulkhead to the floor. See **INSTALLATION INSTRUCTIONS FOR BLIND FASTENERS** on page 6. Do not use blind fasteners over gasoline or CNG tanks or fuel lines. (Alternate hardware is included to follow any of the bolting solutions below.) **Do not bolt the bulkhead to the floor yet.**

NOTE: The floor bolting solution could be a variation on any of these three examples with or without the floor mat.

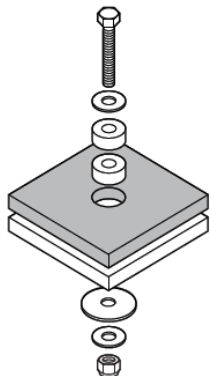

TOP DOWN INSTALLATION THROUGH FLOOR MAT AND VAN FLOOR

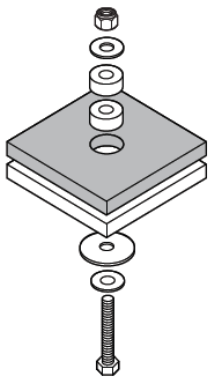

BOTTOM UP INSTALLATION THROUGH FLOOR MAT AND VAN FLOOR

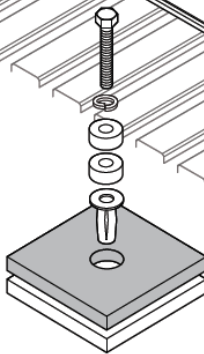

BLIND FASTENER INSTALLATION THROUGH FLOOR MAT AND VAN FLOOR (SEE PAGE)

! WARNING

All floor mounting bolts near the fuel tank area should be installed from the underside of the vehicle, to guard against the fuel tank being punctured in the event of a collision. This would mean not using Blind Fasteners in this area. Holes in this area should be 5/16". Ensure ample space in roof ribs and sidewall ribs for mounting hardware so as not to puncture exterior roof or wall.

INSTALLATION INSTRUCTIONS

STEP 6. With the Bulkhead against the B-Pillar trim, use a marker or pencil and mark the six Bulkhead side holes on the B-pillar trim. Move the Bulkhead out of the way. Drill a pilot hole with an 1/8" drill bit. Re-drill the hole with a 3/8" bit for the blind fasteners.

The 1/2" thick Mounting Spacers are **required**. Cut the B-pillar trim with a 1" hole saw, allowing 1/2" Mounting Spacers to rest against the metal of the B-pillar. Install six (6) 1/4-20 blind fasteners. See **INSTALLATION INSTRUCTIONS FOR BLIND FASTENERS** on page 6.

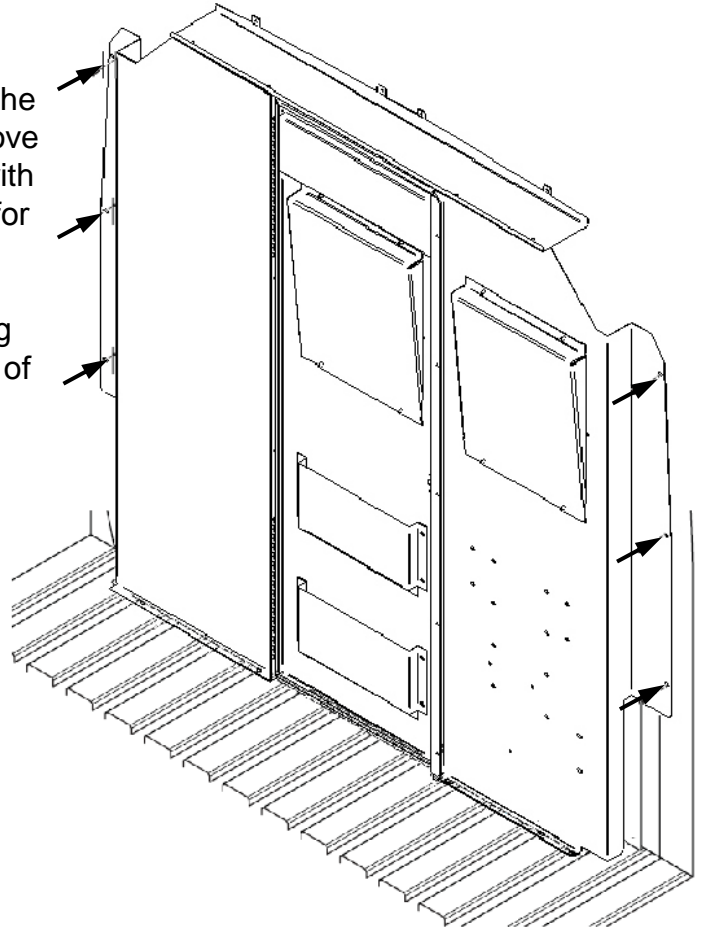

STEP 7. With the Bulkhead against the B-Pillar trim, use a marker or pencil and mark the four Bulkhead header holes on the roof panel. Move the Bulkhead out of the way. Drill a pilot hole with an 1/8" drill bit. Cut the roof trim with a knife or 1" hole saw if necessary.

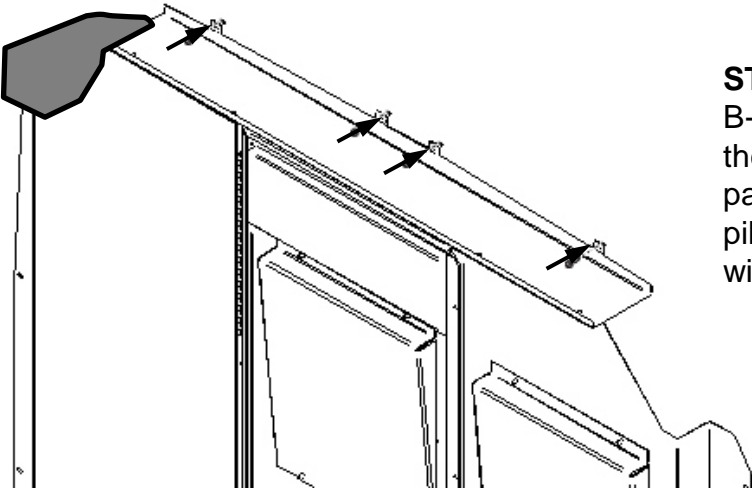

STEP 8. Re-position the bulkhead and install using six (6) 1/4-20 x 1-1/4" hex head bolts and the six (6) 1/2" Mounting Spacers into the B-pillar blind fasteners.

INSTALLATION INSTRUCTIONS

STEP 9. Fasten Bulkhead to van floor using four (4) 5/16-18 x 2" Hex Head Bolts, 5/16" Flat Washers, and four (4) Floor Mounting Spacers.

STEP 11. Bend the tabs on the header panel to sit flush against the roof panel. install using four (4) 1/4-14 x 3/4" hex head thread-cutting bolts into the roof panel.

STEP 11. Re-check all fasteners and tighten them.

STEP 12. If mounting shelf units next to the bulkhead, the foam block on the driver's side will need to be trimmed flush to the bulkhead. Discard the trimmed section. Do not remove the entire foam block. The side airbag is located behind it.

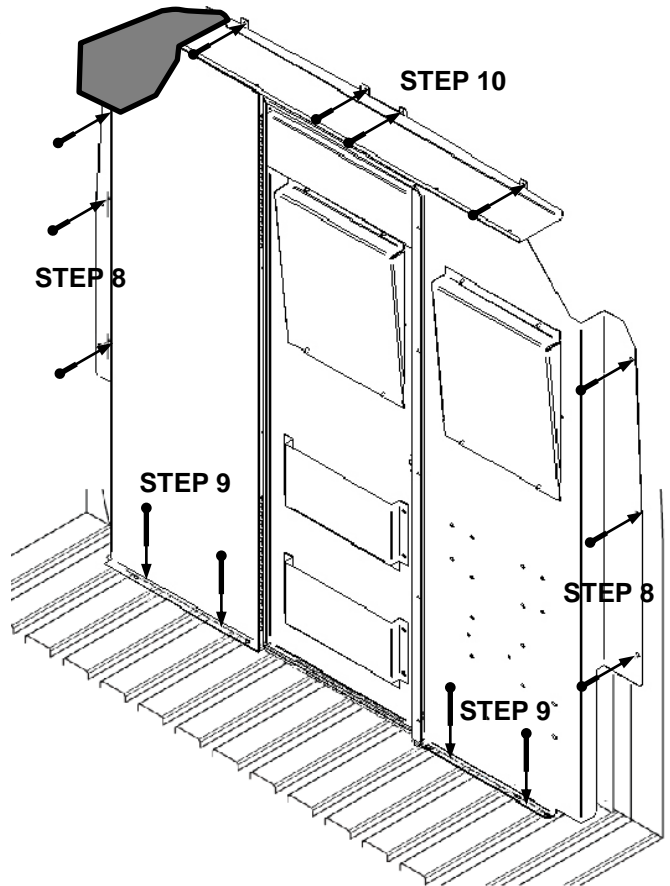
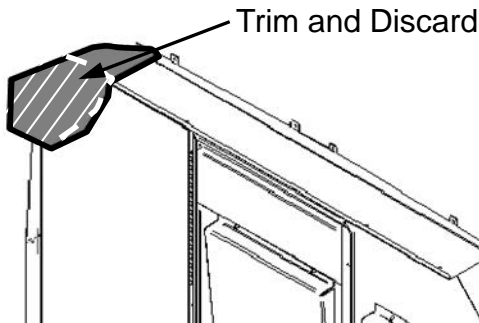

INSTALLATION INSTRUCTIONS FOR BLIND FASTENERS

Place a drop of oil on the black oxide bolt before assembling as shown on right. Place the Blind Fastener in the hole and use a 1/2" wrench to tighten black hex bolt until the Blind Fastener is fully seated. When setting black hex bolt, it will start out hard. As the Blind Fastener "bulbs" out it will get easier, until it bottoms out or sets. Make sure the Blind Fastener and Installation Tool do not turn during installation.

