

ASSEMBLY, WIRING, and SEALANT INSTRUCTIONS

HEAVY-DUTY PROTECT-A-RAIL 1908

PARTS LIST

- 1 Lower Protect-A-Rail Section
- 1 Upper Protect-A-Rail Section

HARDWARE KIT

- 4 3/8-16 x 3" Hex Head Bolt
- 4 3/8-16 Nylon Lock Nut
- 8 3/8 Flat Washer
- 1 Tube (Black Adhesive Sealant)
- 2 Red Cap
- 2 Square Plastic Plug
- 6 7/16 Dia. Plastic Snap-In Bushing
- 2 7/8 Dia. Plastic Plugs
- 1 Tube (Cap Adhesive)

TOOLS REQUIRED

- 1/2" Open or Box End Wrench
- 9/16" Open or Box End Wrench (2)
- Electric Drill w/ 1/8" and 7/16" bits

Select the desired height of the Protect-A-Rail for your vehicle and install the four 3/8-16 x 3" fasteners. If you are installing any accessories that require wiring, two snap bushing have been installed internally to protect the wiring. Any additional holes that are added will have to have snap bushings also to protect the wiring. In the bottom of the unit you will need to install two 7/8" dia. plugs. To install wiring drill a 1/8" dia. hole in the center of the plug(s). Depending on the quantity and size of the wires this hole may have to be larger. The illustration below shows the open pathways for the wire. After wiring has been installed, insert the two square plugs into the top openings. Next apply a couple of drops of the cap adhesive (1/4 oz. tube) to the inside of the red caps and slide them down over the top of the tubes with the square plugs.

NOTE:

Extra snap bushings have been provided for any wiring holes (7/16" dia.) that are added.

If wiring is desired on the side areas, drill a 7/16" dia. hole 5/8" below the 1" x 2" tube.

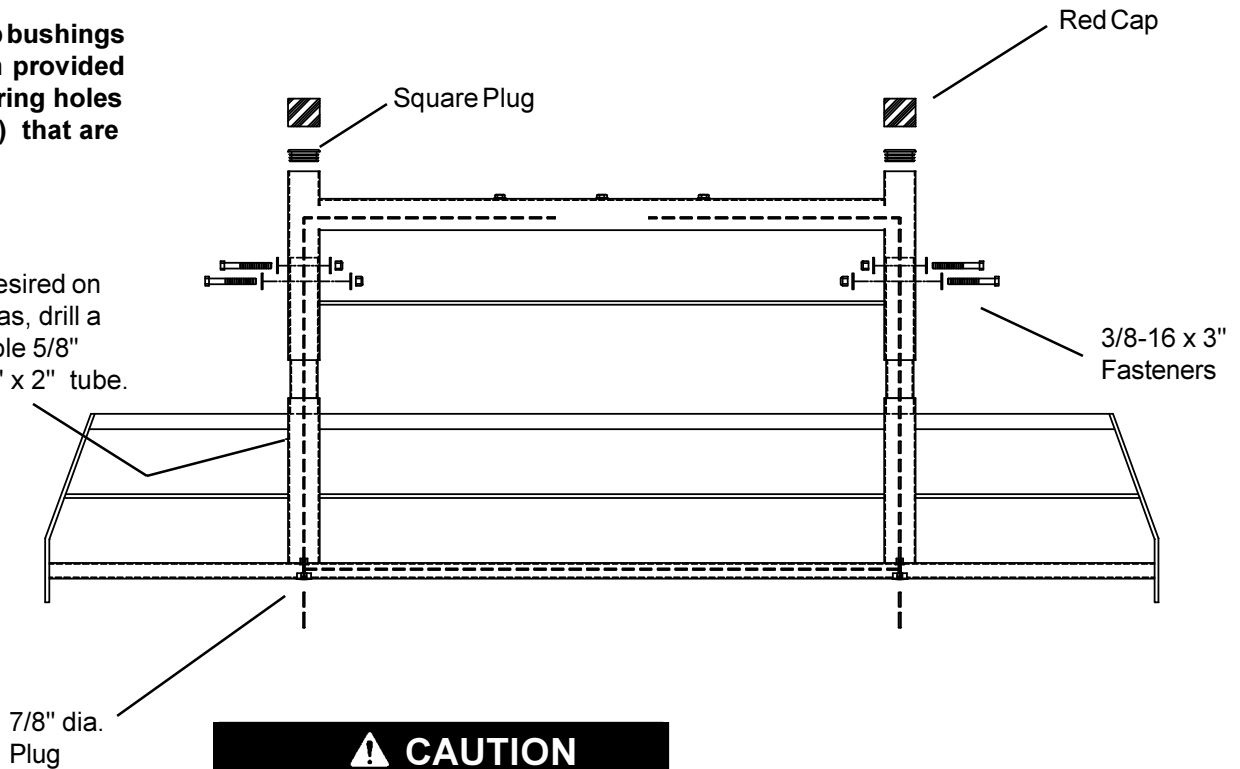

⚠ CAUTION

To keep debris out of your eyes when drilling, always wear protective eyewear.



After the unit is completely wired and all fasteners are tight, you will need to apply the sealant (3 to 4 oz. tube) to all fasteners, wiring holes, and joints that would allow water into the tubing. The key areas have been circled below. You will also need to seal any additional holes you drill into the tubing. Warranty will be void if sealant is not applied to all seams, openings and fasteners. The three accessory fasteners on top of the unit are sealed, but if removed, they will need to be resealed.

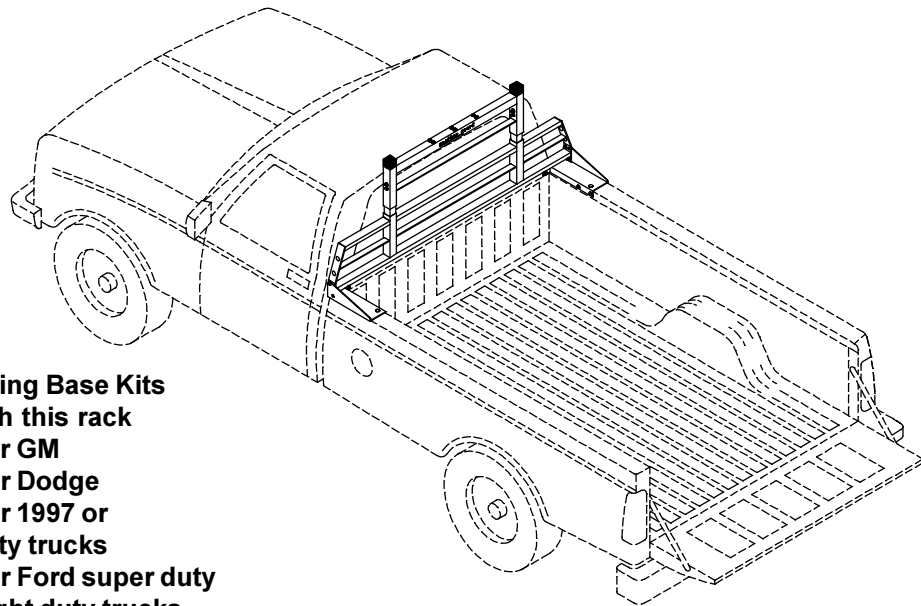
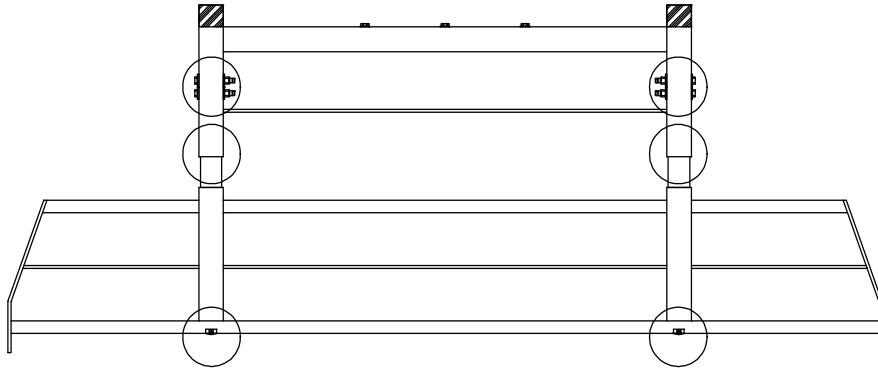

- One of the following Mounting Base Kits
will be required with this rack**
- 1916 - Mounting Base Kit for GM**
 - 1912 - Mounting Base Kit for Dodge**
 - 1913 - Mounting Base Kit for 1997 or
newer Ford light duty trucks**
 - 1915 - Mounting Base Kit for Ford super duty
and 1996 or older light duty trucks**