



**TRUCK STORAGE SOLUTIONS**  
**SECURING YOUR REPUTATION®**

# INSTALLATION MANUAL

## FAST RACK® LADDER SYSTEM

**ATTENTION: PLEASE READ AND UNDERSTAND ALL INSTRUCTIONS AND WARNINGS BEFORE ASSEMBLING, INSTALLING OR USING THIS PRODUCT.**

### **MODELS 1280 - Full Size Truck Rack (8ft Bed)**

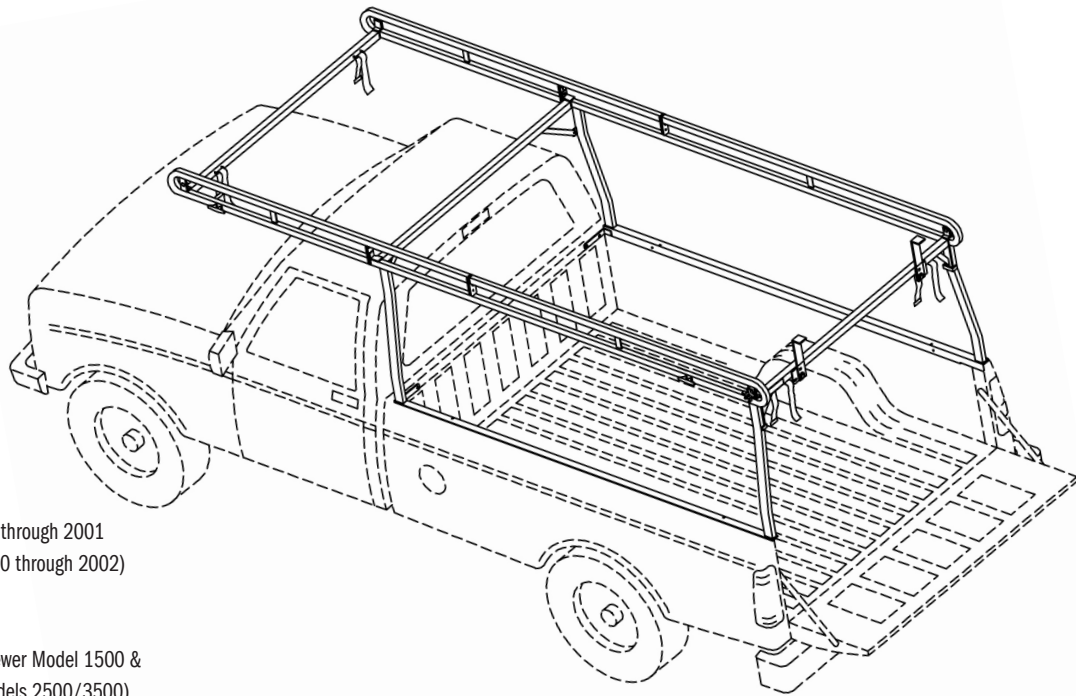

Crossmembers are packaged separately per vehicle model.

- 1281 GM
- 1282 Dodge (Model 1500 through 2001 & Models 2500/3500 through 2002)
- 1283 Ford
- 1284 Super Duty Ford
- 1287 Dodge (2002 and newer Model 1500 & 2003 and newer Models 2500/3500)

### **▲ NOTICE**

Use specific aluminum upfit components when installing WEATHER GUARD® products to aluminum truck beds. Follow additional instructions if mounting to an aluminum truck bed. There may be left over components depending on upfit.

Any modification or unintended use of this product shall immediately void all manufacturers warranties. Manufacturer disclaims all liability for injuries to persons or property resulting from any modification to, or unintended use of this product.

### **▲ DANGER**

Danger of explosion. Do not use this product for storing or transporting flammables, explosives, hazardous materials, or hazardous waste, such as containers of gasoline, solvents, gun powder, dynamite, propane tanks, acetylene tanks and cutting torches. This product is only intended and safe for use in storing and transporting small tools, equipment and other similar materials. Any modifications made to, or unintended use of this product, could create a hazardous condition that can cause death, serious personal injury or property damage.

### **▲ CAUTION**

To keep debris out of your eyes when checking the underside of the vehicle, or when drilling, always wear protective eyewear. Never load your rack to exceed the safe rated capacity of your vehicle. Heavy loads carried high can dangerously alter the center of gravity.

### **▲ WARNING**













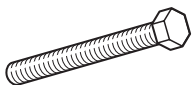

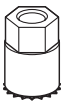
Prior to drilling, so as not to cut or puncture fuel tanks, fuel lines, electric wires, etc., check under vehicle for locations. All floor mounting bolts near the gas tank area should be installed from the underside of the vehicle, to guard against the gas tank being punctured in the event of a collision. This would mean not using Blind Fastener in this area. Holes drilled in this area should be 3/8". This product is only intended for, and only safe for, transporting ladders, lumber, pipe and other similar materials. It is the responsibility of the user to secure these materials to the rack before transporting. Any modifications made to this product or use of this product for any other purpose than its intended use, will create a hazardous condition that can cause serious personal injury or property damage.

Ladders must be secured per ANSI standard A142.2-1990 paragraph 8.4.4. Ladder damage will occur from road shock and vehicle vibration if the ladder is not properly secured to the ladder rack. Bouncing and side to side motion of an improperly secured ladder will cause wear and weaken the ladder. Using a damaged ladder could lead to a structural collapse and could result in a serious injury or death.

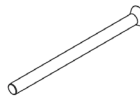
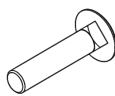
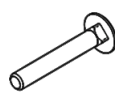
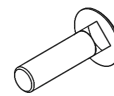
## TOOLS REQUIRED

- 3/8" Drive Ratchet
- Sockets - 7/16" & 1/2"
- Electric Drill
- Drill Bits - 7/32", 1/4" & 1/2"
- Open or Box End Wrench - 1/2", 7/16", 9/16"
- C-clamp
- Screwdriver (common)

## PARTS LIST

 (4) 5/16-18 x 1-1/2" Hex Head Bolt	 (4) 1/4-20 x 1-1/4" Hex Head Bolt	 (1) 5/16-18 x 2-1/4" Black Oxide Bolt	 (4) 5/16" Lock Washer	 (12) 1/4" Flat Washer
 (1) Installation Tool	 (4) 5/16-18 Blind Fastener	 (8) 5/16-18 Nylon Lock Nut	 (8) 1/4-20 Nylon Lock Nut	 (8) 10-24 Nylon Lock Nut
 (8) 10-24 x 2-3/4" Flat Head Screw	 (2) 5/16-18 x 1-1/4" Carriage Bolt	 (4) 1/4-20 x 1-1/2" Carriage Bolt	 (6) 5/16-18 x 1" Carriage Bolt	 (8) 5/16" Flat Washer
 (1) Driver Side Leg (1) Passenger Side Leg	 (1) Driver Side Front Rail (1) Passenger Side Front Rail	 (1) Tube E-6000 Sealant	 (4) Black Tie Downs	

## ALUMINUM BED UPFIT KIT PARTS LIST - 32-0243

 (4) Vinyl Tape	 (1) Zinc Rich Primer	 (8) 1/2" x 1" Plastic Washer	 (4) 11/32" x 7/8" Plastic Washer	 (8) 5/16" x 3/4" Plastic Washer
--	--	--	--	---

## BLIND FASTENER INSTALLATION

Place a drop of oil on black oxide bolt for lubrication before assembling.

Place the Blind Fastener in the hole and use 1/2" or 7/16" wrench to tighten black oxide bolt until fastener is fully seated (it will start out hard and get easier as fastener "bulbs" out).

Make sure the Blind Fastener and Installation Tool do not turn during installation.

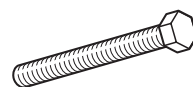

**Black Oxide Bolt**



**Flat Washer**

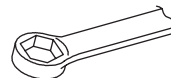

**9/16" Wrench**

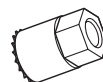

**Installation Tool**



**Blind Fastener**

## ALUMINUM TRUCK BED INSTALLATION

Coat drilled holes with Zinc Rich Primer. Insert Blind Fastener through one 1/2" x 1" plastic washer. Insert Blind Fastener into drilled hole. Place second 1/2" x 1" plastic washer through the bottom of the Blind Fastener. Continue following installation instructions above to install Blind Fasteners.

# INSTALLATION INSTRUCTIONS

**Note:** If your truck bed is constructed of aluminum, use zinc rich primer to coat drilled holes.

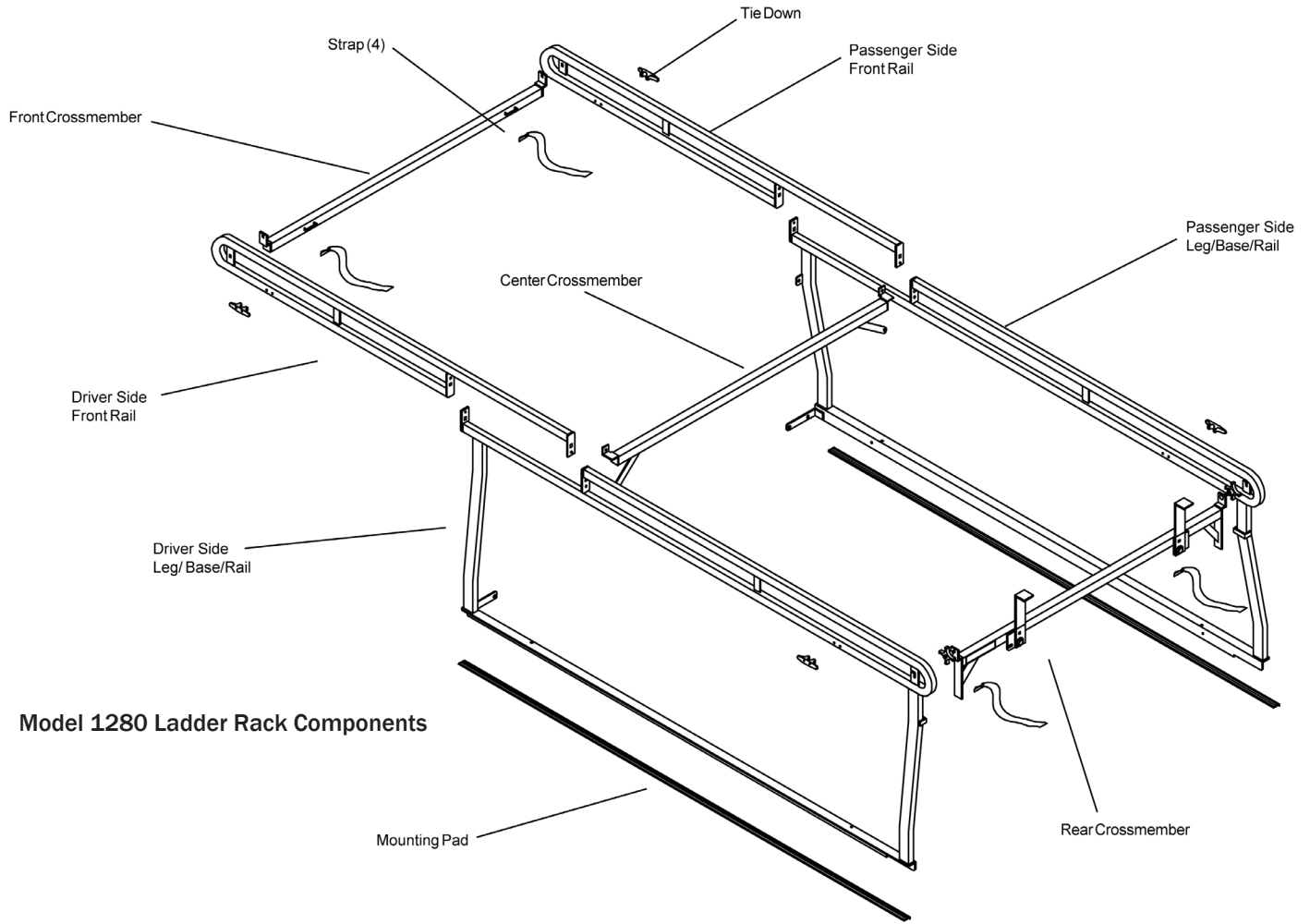

Model 1280 Ladder Rack Components

## STEP 1 Rail Assembly

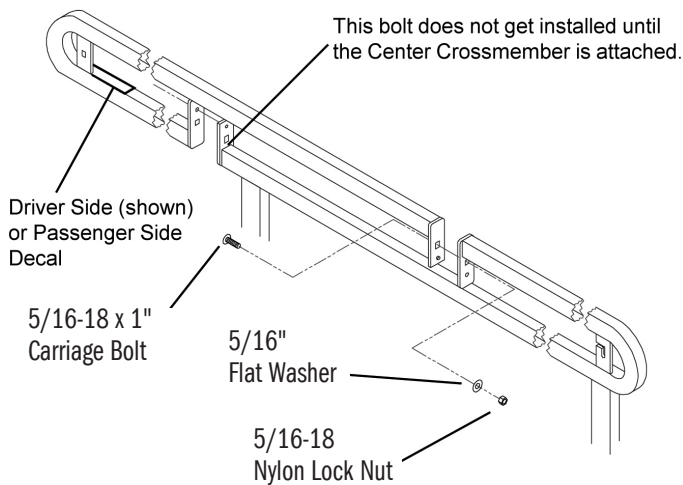

## STEP 2 Tie Down Installation

Install tie downs where desired. Put E-6000 sealant on the back of the tie downs and under nuts before installing.

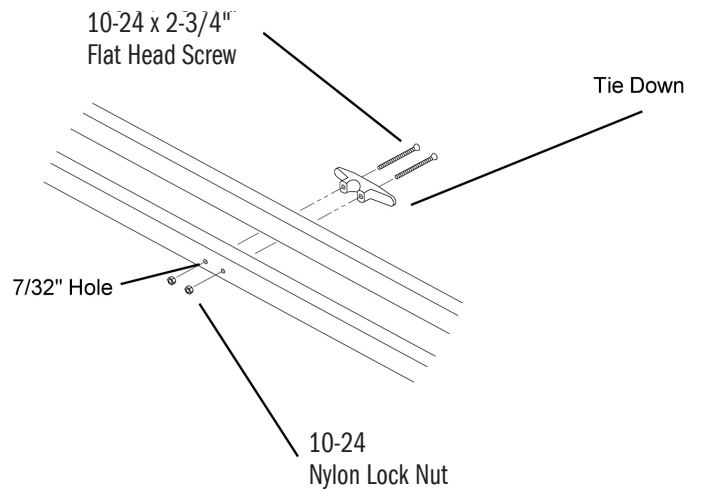

### STEP 3 Mounting Pad Installation

Place pads on the top of the bed. It may be necessary to hold the pads in place with small pieces of tape.

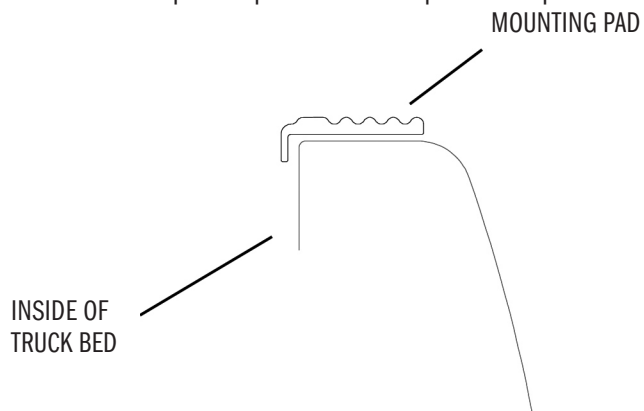

### STEP 4 Rail and Rear Crossmember Installation

With the help of at least two other people, lift one of the assembled sections onto the truck. One person should be in the truck to hold the first section while the other section is being lifted into position. Once both sections are positioned, install the rear crossmember as shown in Step 5.

### STEP 5 Rear Crossmember Assembly (Ladder Stop not shown for clarity)

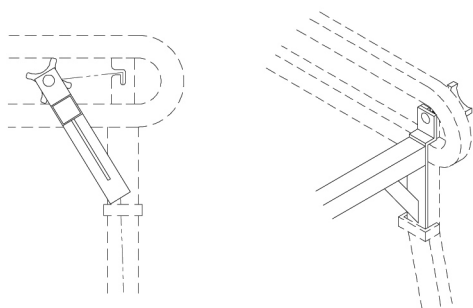

### STEP 6 Front Crossmember Assembly

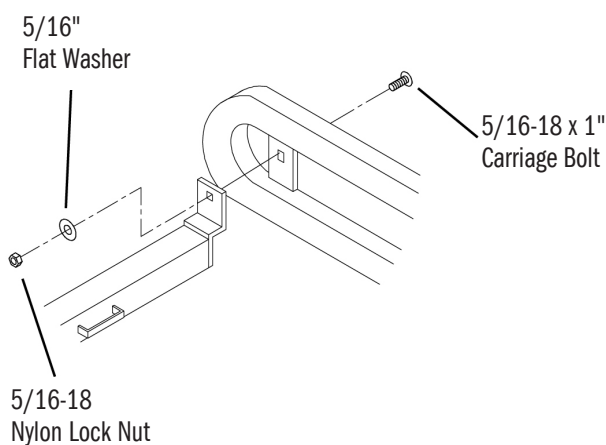

### STEP 7 Center Crossmember Assembly

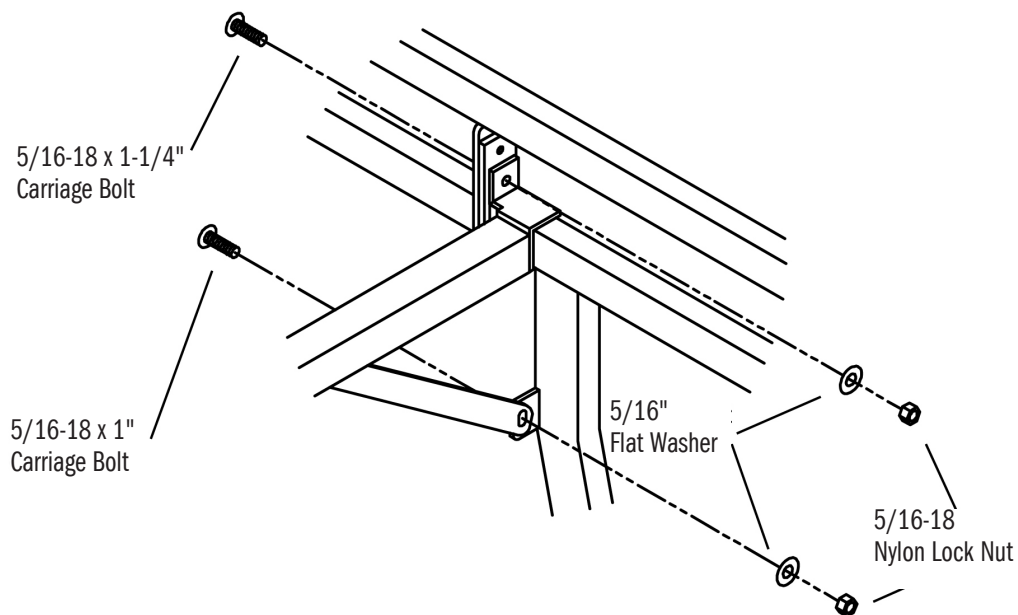

**PERFORM THE FOLLOWING STEPS TO THE DRIVER SIDE & PASSENGER SIDE** (Passenger Side Shown)

**Note:** If your truck bed is constructed of aluminum, use zinc rich primer to coat drilled holes.

**STEP 8** Mounting Base Location

Tape washer, clamp, and drill front side.

TAPE A 5/16" FLAT WASHER  
BETWEEN FRONT OF  
MOUNTING BASE AND BED

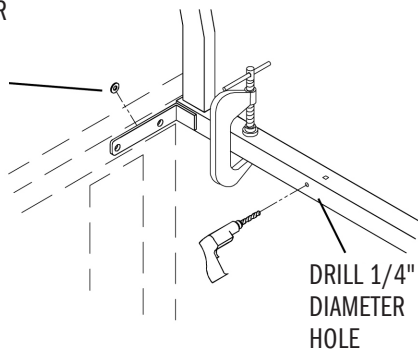

**STEP 9** Top & Front Drill Procedure

Unclamp, remove flat washer, and fasten side.

**ALUMINUM TRUCK BED INSTALLATION:**

Use one 5/16" x 3/4" plastic washer as a barrier between the 1/4" flat washer and the truck bed.

1/4-20 x 1-1/4"  
Hex Head Bolt

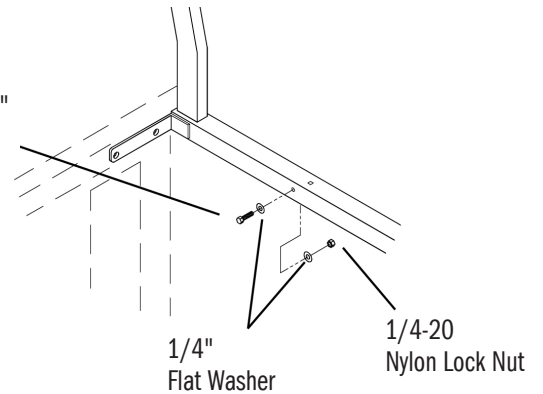

**STEP 10** Drill Front and Top

CENTERED IN 3/8"  
DIAMETER HOLES

DRILL (2) 1/2"  
DIAMETER HOLES

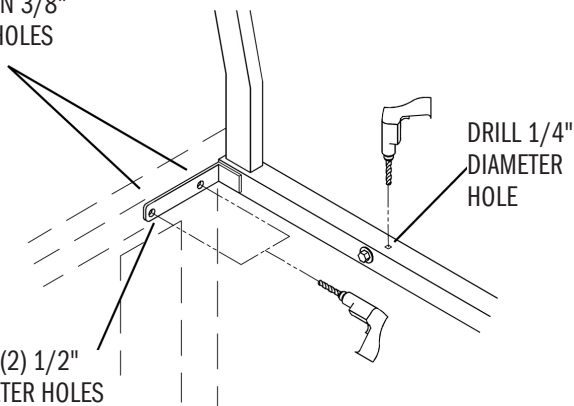

**STEP 11** Top & Front Re-Drill Procedure

Unfasten side, move rack out of the way, re-drill front holes, and install Blind Fasteners.

**ALUMINUM TRUCK BED INSTALLATION:**

Follow additional instructions if mounting to an aluminum truck bed as explained in the Blind Fastener Installation on page 2.

5/16-18  
Blind Fastener

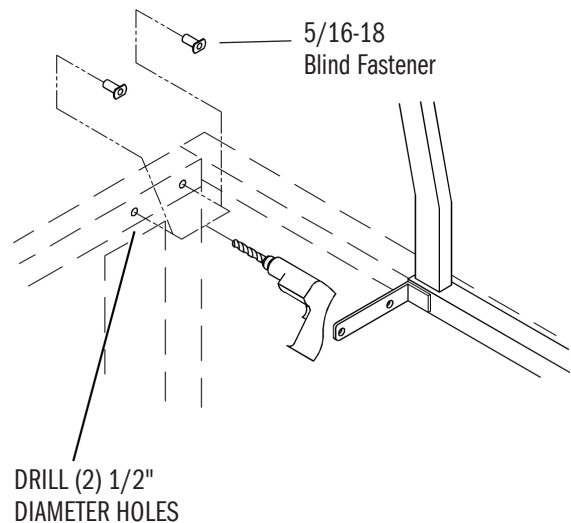

## STEP 12 Install Front, Top, and Side Fasteners

### ALUMINUM TRUCK BED INSTALLATION:

Use one 5/16" x 3/4" plastic washer as a barrier between the 1/4" flat washer and the truck bed.

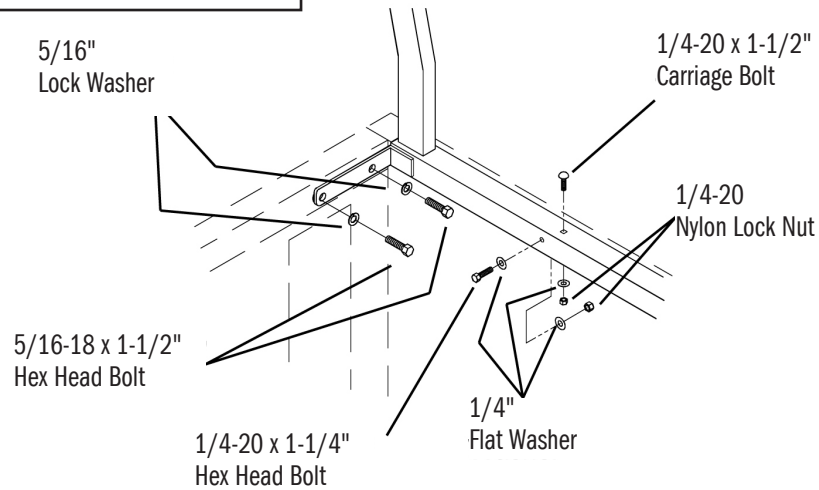

## STEP 13 Clamp, Drill, and Fasten Rear Side

### ALUMINUM TRUCK BED INSTALLATION:

Use one 5/16" x 3/4" plastic washer as a barrier between the 1/4" flat washer and the truck bed.

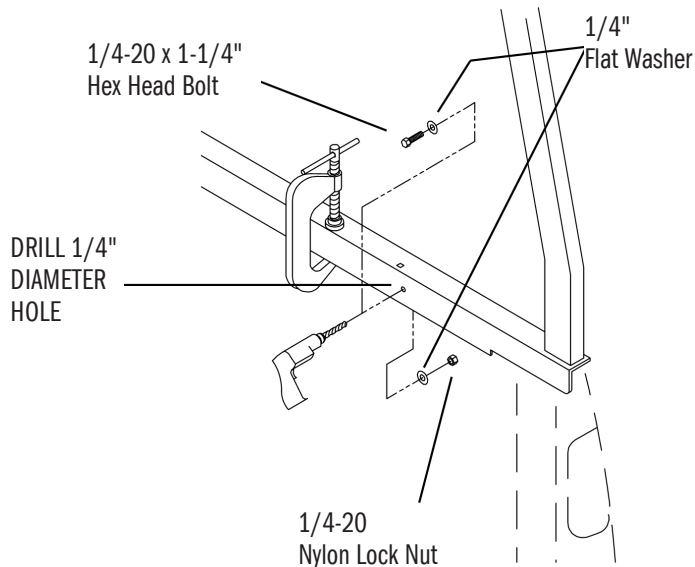

## STEP 14 Remove Clamp, Drill, and Fasten Rear Top

### ALUMINUM TRUCK BED INSTALLATION:

Use one 5/16" x 3/4" plastic washer as a barrier between the 1/4" flat washer and the truck bed.

