

INSTALLATION INSTRUCTIONS

Accessory Airfoil - Model 1246 & 1247

for Ladder Rack Models 1245/1275/1280

Approximate Assembly and Installation time:
12 min. per unit (.199 hrs.)
 Depending on truck equipment installation experience

IMPORTANT BEFORE YOU BEGIN

Read these instructions and warnings completely before installation.

BOLT KIT

Bolt Kit #32-0017 is provided with your Airfoil. Check this bolt kit to be sure the following parts are included:

Quan.	Description
6	1/4-14 x 3/4" Self Drilling Screw

TOOLS REQUIRED

- Ruler
- 5/16" Nut Driver
- Electric Drill with 5/32" bit
- Pencil
- Oil

Model 1246 is needed if your Ladder Rack is mounted on an extended cab Ford Super-Duty Pickup

Hold Airfoil flush with the top of the Crossmember

Mark through the mounting holes

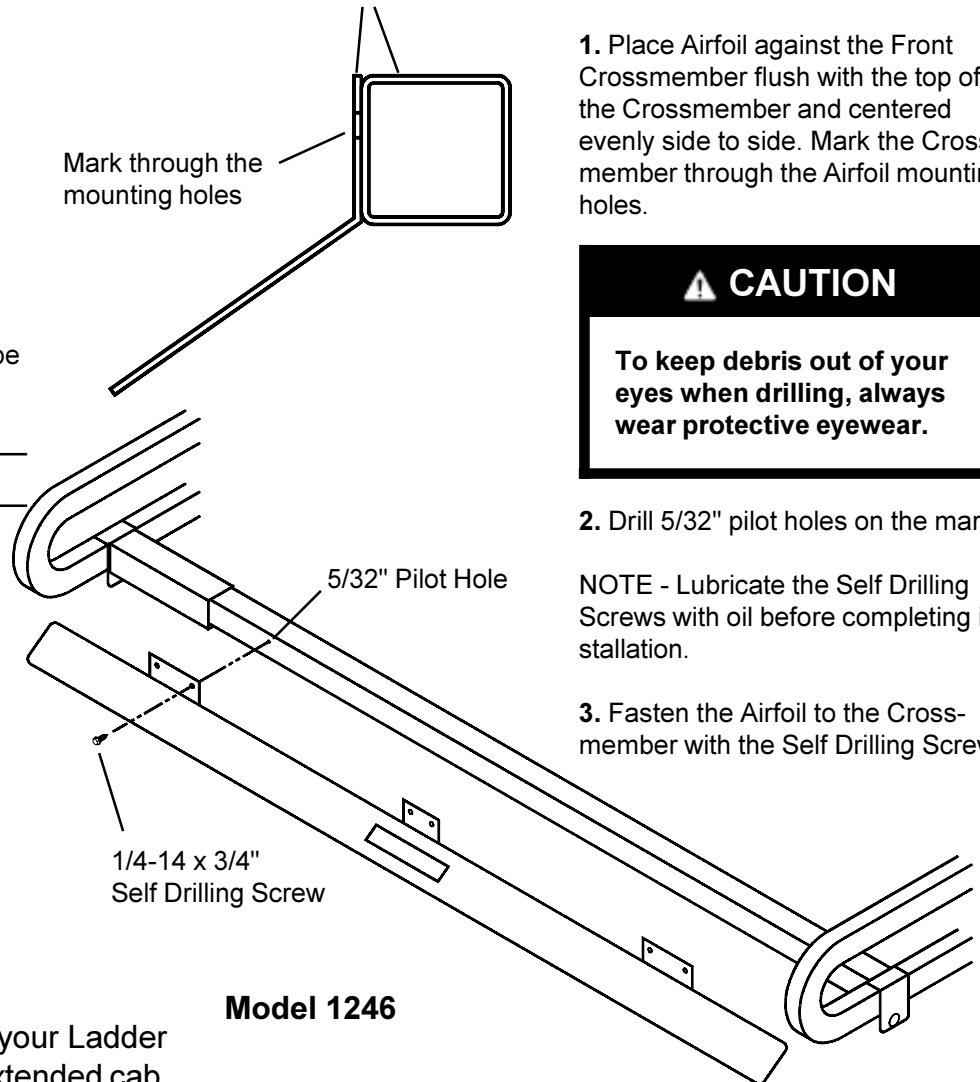

Model 1246

INSTALLATION INSTRUCTIONS

1. Place Airfoil against the Front Crossmember flush with the top of the Crossmember and centered evenly side to side. Mark the Crossmember through the Airfoil mounting holes.

⚠ CAUTION

To keep debris out of your eyes when drilling, always wear protective eyewear.

2. Drill 5/32" pilot holes on the marks.

NOTE - Lubricate the Self Drilling Screws with oil before completing installation.

3. Fasten the Airfoil to the Crossmember with the Self Drilling Screws.



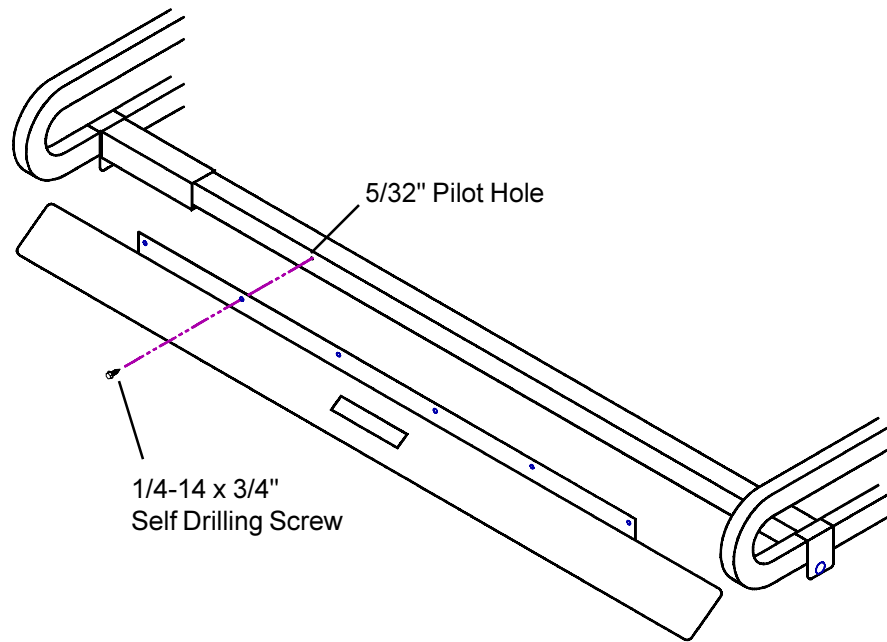

Model 1247 is needed if your Ladder Rack is mounted on an extended cab GM, Dodge, or Ford F-150 Pickup or a GM 4-Door Crew Cab Pickup

Model 1247

NOTE - To reduce wind noise, it may be necessary to bend the Airfoil down slightly until the wind noise is gone.