



# INSTALLATION INSTRUCTIONS

## HEAVY DUTY WINCH BUMPER

Part Number: 73040

Application: 2007 TOYOTA FJ CRUISER

Your safety, and the safety of others, is very important. To help you make informed decisions about safety, we have provided installation and operating instructions and other information on labels and in this guide. This information alerts you to potential hazards that could hurt you or others. It is not possible to warn you about all potential hazards associated with this product, you must use your own good judgment.

**CARELESS INSTALLATION AND OPERATION CAN RESULT IN SERIOUS INJURY OR EQUIPMENT DAMAGE. READ AND UNDERSTAND ALL SAFETY PRECAUTIONS AND OPERATING INSTRUCTIONS BEFORE INSTALLING AND OPERATING THIS PRODUCT.**

This guide identifies potential hazards and has important safety messages that help you and others avoid personal injury or death. **WARNING** and **CAUTION** are signal words that identify the level of hazard. These signal words mean:

**⚠ WARNING** signals a hazard that could cause serious injury or death, if you do not follow recommendations.

**⚠ CAUTION** signals a hazard that may cause minor to moderate injury, if you do not follow recommendations.

This guide uses **NOTICE** to call attention to important mechanical information, and **Note**: to emphasize general information worthy of special attention.

### **⚠ WARNING**

#### **INJURY HAZARD**

**Failure to observe these instructions could lead to severe injury or death.**

- Always** Read the Winch Operator's Manual and all warning labels before operating.
- Always** use extreme caution when drilling on any vehicle. Make sure that all fuel lines, brake lines, electrical wires, and other objects are not punctured or damaged when/if drilling on the vehicle. Thoroughly inspect the area to be drilled (on both sides of material) prior to drilling, and relocate any objects that may be damaged. Failure to inspect the area to be drilled may result in vehicle damage, electrical shock, fire or personal injury.
- Always** wear safety glasses when installing this kit. A drilling operation will cause flying metal chips. Flying chips can cause eye injury.
- Always** use extreme caution when cutting and trimming during fitting.
- Always** remove jewelry and wear eye protection.
- Never** lean over battery while making connections.
- Never route electrical cables:**
  - o Across any sharp edges.
  - o Through or near moving parts.
  - o Near parts that become hot.
- Always** insulate and protect all exposed wiring and electrical terminals.
- Always** install terminal boots as directed in installation instructions.
- Always** use appropriate and adequate care in lifting components into place.
- Always** insure components will remain secure during installation and operation.
- Always** tighten all nuts and bolts securely, per the installation instructions..
- Always** replace all worn or damaged parts before operating.
- Never** operate this WARN product with damaged or missing parts.

### **Notice**

#### **Equipment Damage**

- Always** refer to the Installation and Specification Guide, supplied in the winch kit, for all wiring schematics and specific details on how to wire this WARN product to your vehicle.  
**Read installation and operating instructions thoroughly.**

### **NOTES**

This bumper is not compatible with the factory optional front skid plate. Optional skid plate must be removed for bumper installation.

**Figure 1 Exploded view**

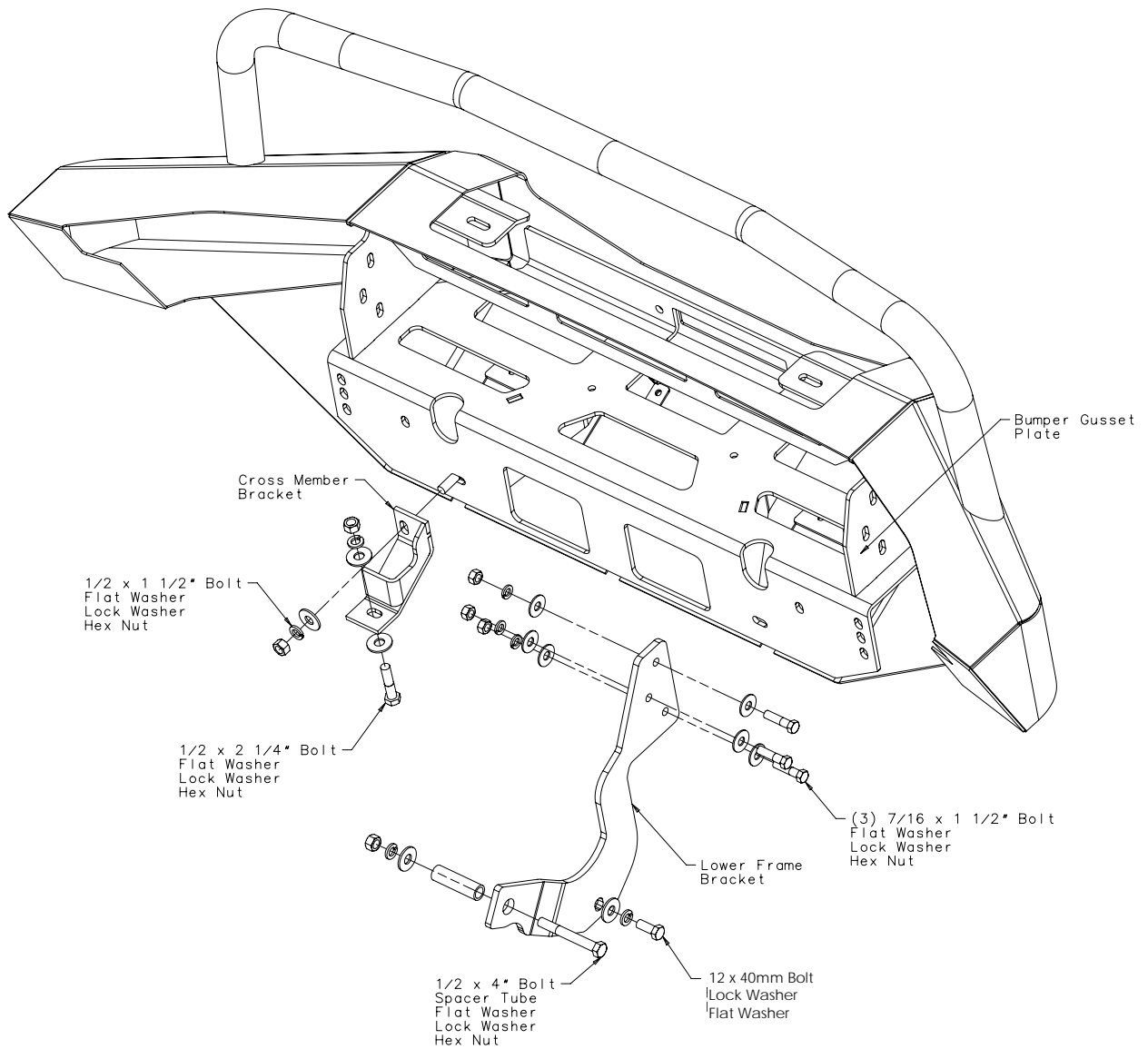

**I. PARTS LIST**

|                          |   |       |
|--------------------------|---|-------|
| Frame Bracket, RH        | 1 | 76196 |
| Frame Bracket, LH        | 1 | 76197 |
| Cross Member Bracket, LH | 1 | 73628 |
| Cross Member Bracket, RH | 1 | 73627 |
| Light Bracket, LH        | 1 | 73775 |
| Light Bracket, RH        | 1 | 73774 |
| License Plate Bracket    | 2 | 73469 |
| Spacer Tube              | 2 | 76198 |

**II. TOOLS REQUIRED**

|                               |                                |
|-------------------------------|--------------------------------|
| 10mm socket                   | 11/16" socket and end wrenches |
| 12mm socket                   | 3/4" socket and end wrenches   |
| 14mm socket                   | Flat blade screw driver        |
| 17mm socket                   | 1/4 and 1/2" drill             |
| 7/16" socket and end wrenches | Safety glasses                 |
| 5/8" socket and end wrenches  |                                |

### III. TORQUE SPECIFICATIONS

|      |                        |
|------|------------------------|
| 1/4  | 8 lb. ft. (10.8 N-m)   |
| 3/8  | 30 lb. ft. (40.7 N-m)  |
| 7/16 | 50lb. ft. (67.8 N-m)   |
| 1/2  | 75 lb. ft. (101.7 N-m) |

### IV. INSTALLATION

1. Remove the screws from the rear corners of the bumper, two in each side. **Figure 2**



**Figure 2** Bumper mounting screws, left side

2. Remove the eight screws along the bottom of the bumper. **Figure 3**

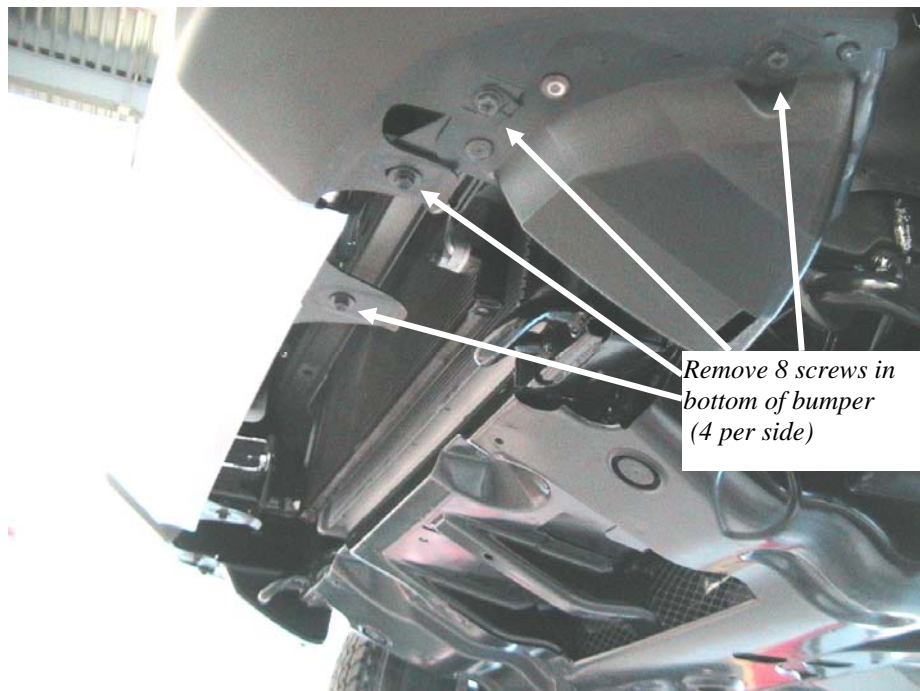

**Figure 3** Lower bumper mounting screws

3. Lift the hood and remove the two screws from the top of the grille. Retain the hardware for use later.  
**Figure 4**

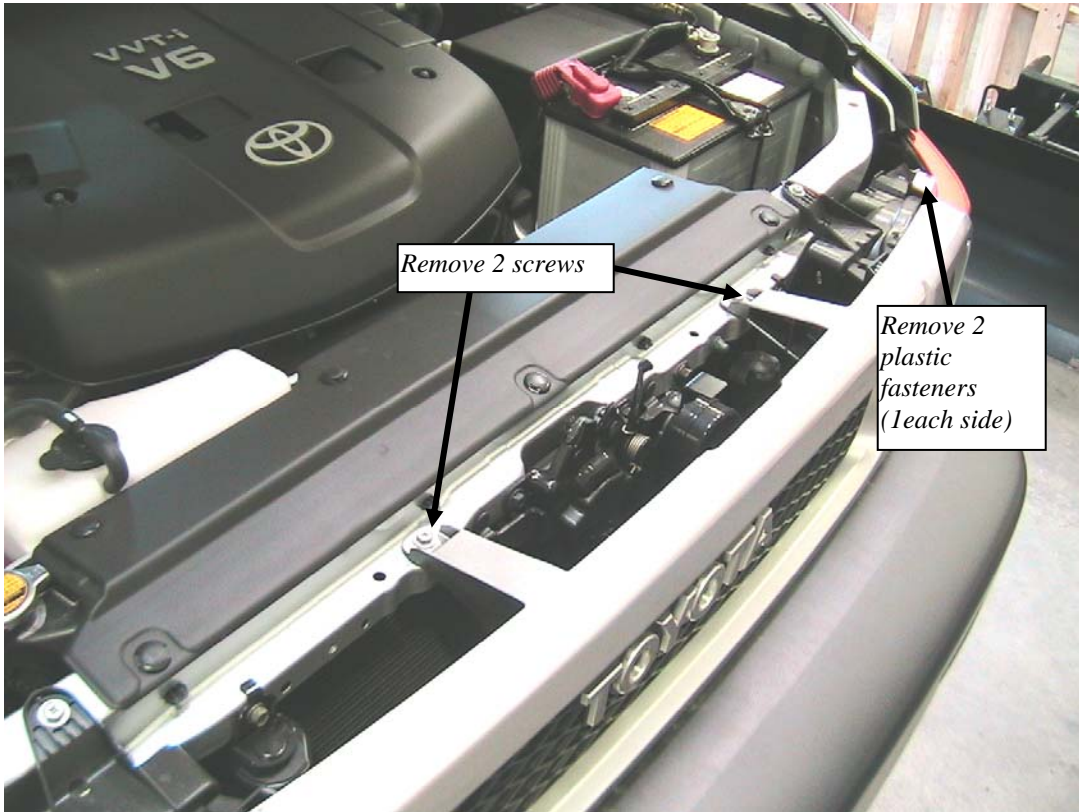

**Figure 4 Grille fasteners**

4. Remove the two plastic fasteners from the top of the grille. Retain the hardware for use later. Carefully pry the center pins up before removing the fasteners. **Figure 5**

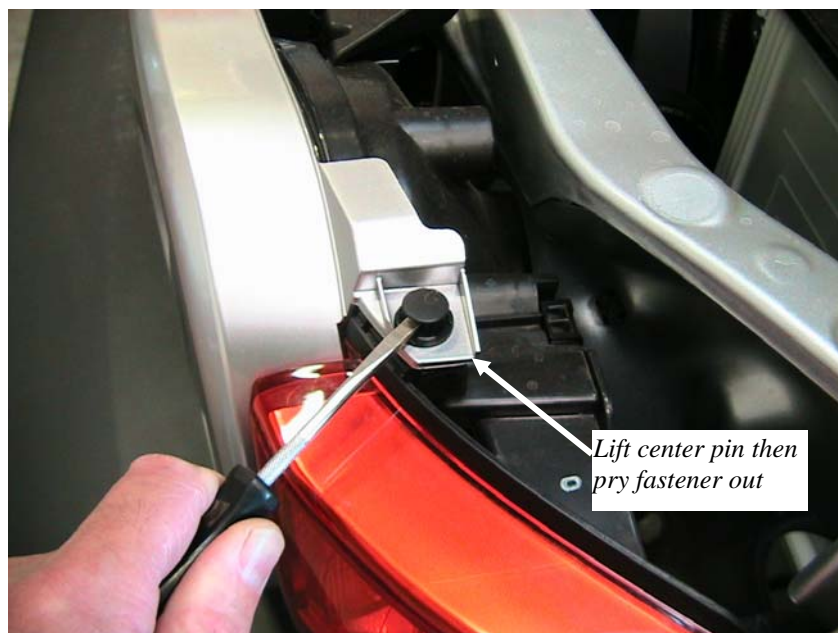

**Figure 5 Left grille fastener removal**

5. Pull the grille free of the retaining clips with a “sharp” pull.

6. Remove five plastic fasteners from the top of the bumper. Two are behind the upper bumper support.  
**Figure 6**

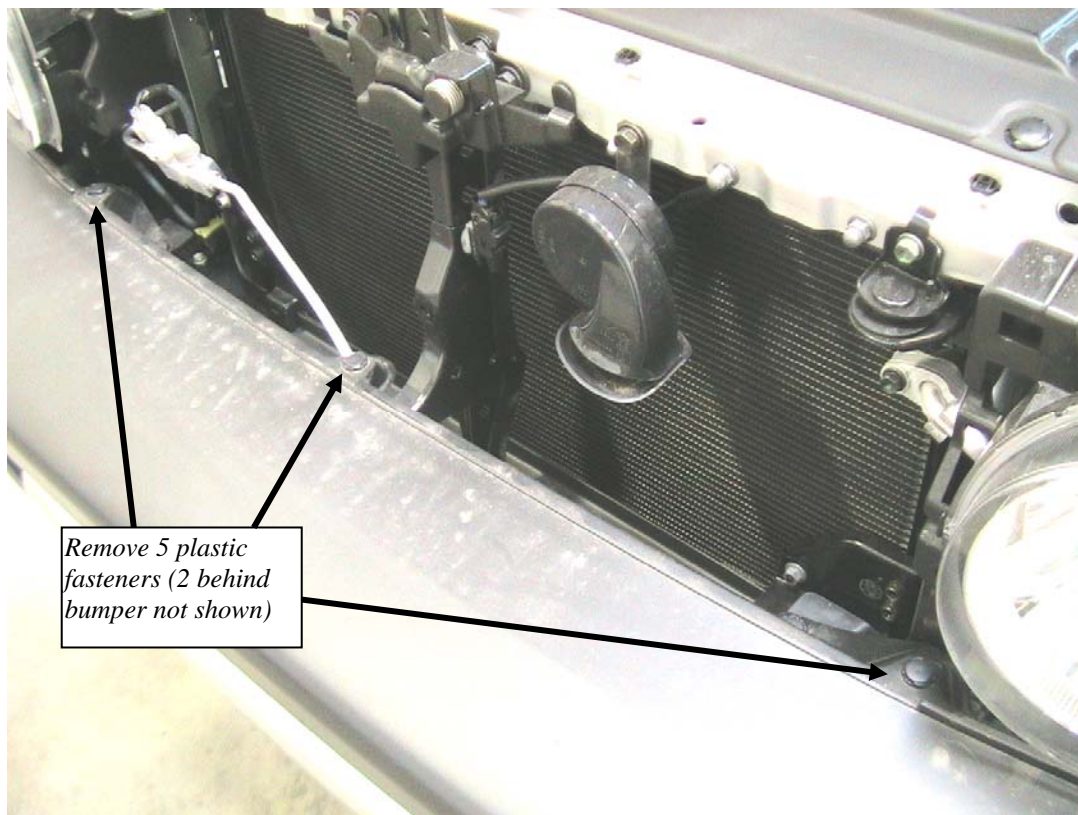

**Figure 6 Bumper fasteners**

7. Pull the bumper corners free by pulling the ends rearward and out. The top of the bumper is snapped into plastic clips just below the fender corners, in front of the flares. Pull the bumper free. **Figure 7**



**Figure 7 Left bumper end removal**

8. Remove the two screws that hold each plastic mounting block in place and remove the blocks. **Figure 8**

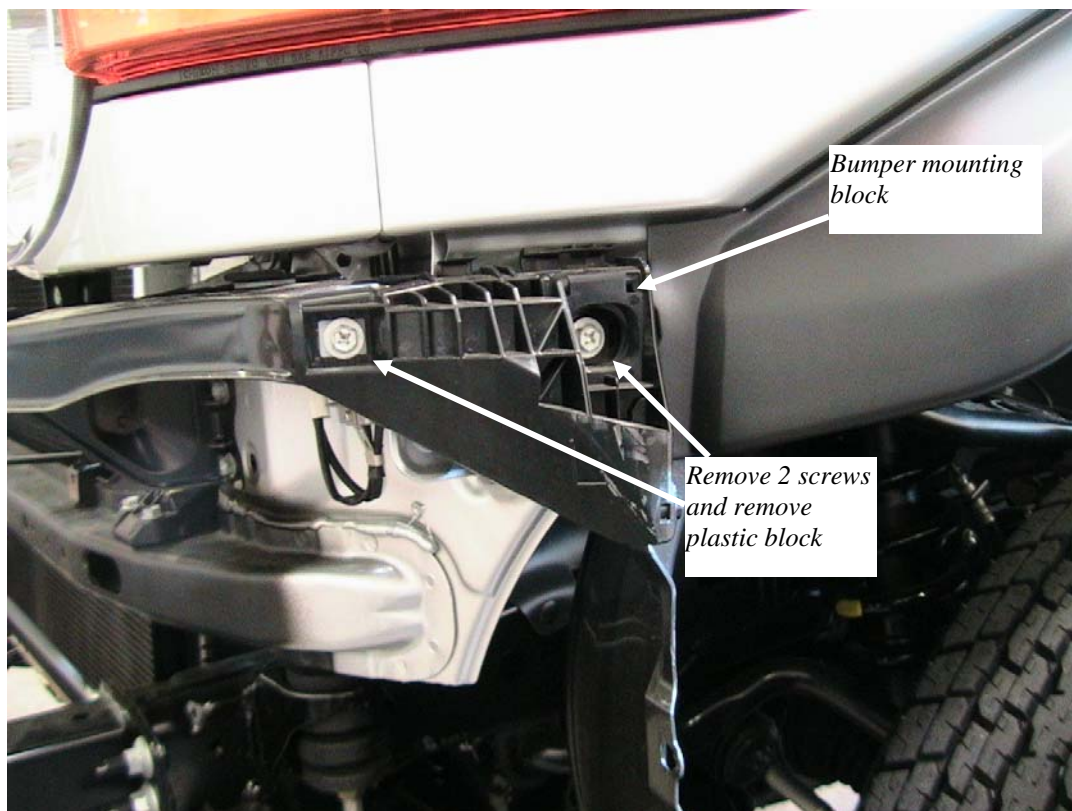

**Figure 8 LH bumper mounting block**

9. Remove the three screws and remove the upper bumper support. **Figure 9**

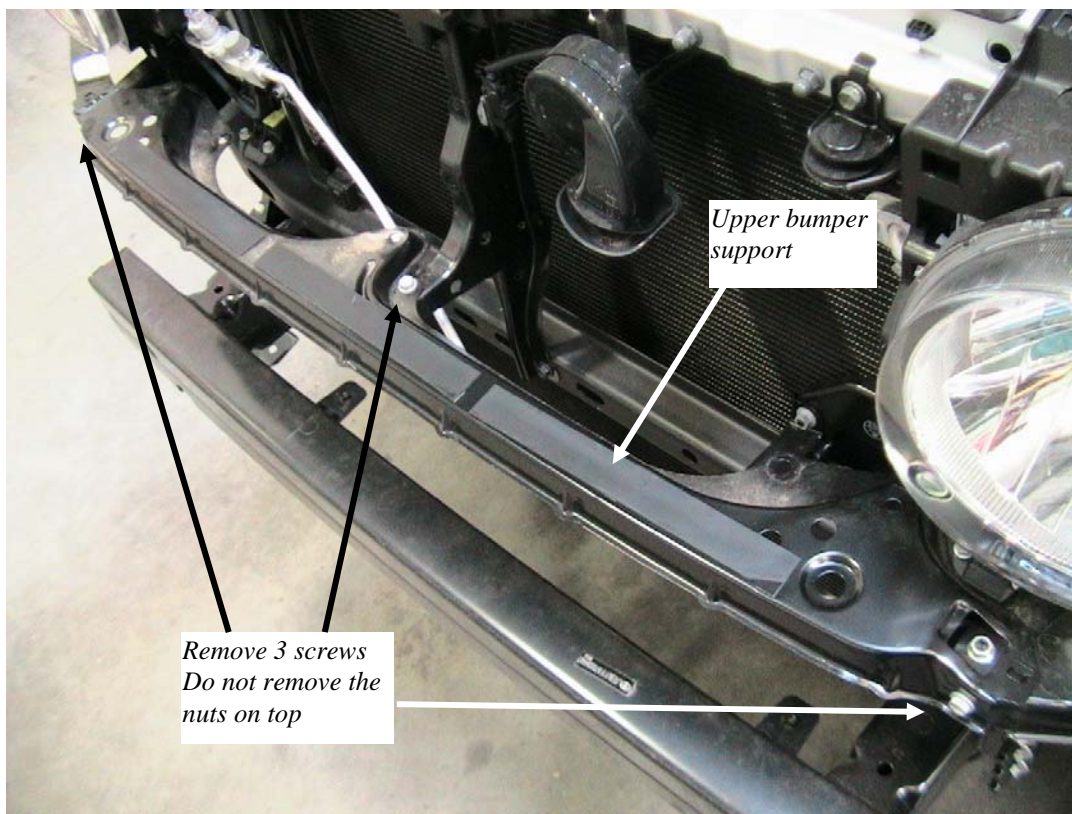

**Figure 9 Upper bumper support**

10. Remove the 8 hex flange nuts and remove the bumper beam. Retain the hardware for bumper installation. **Figure 10**

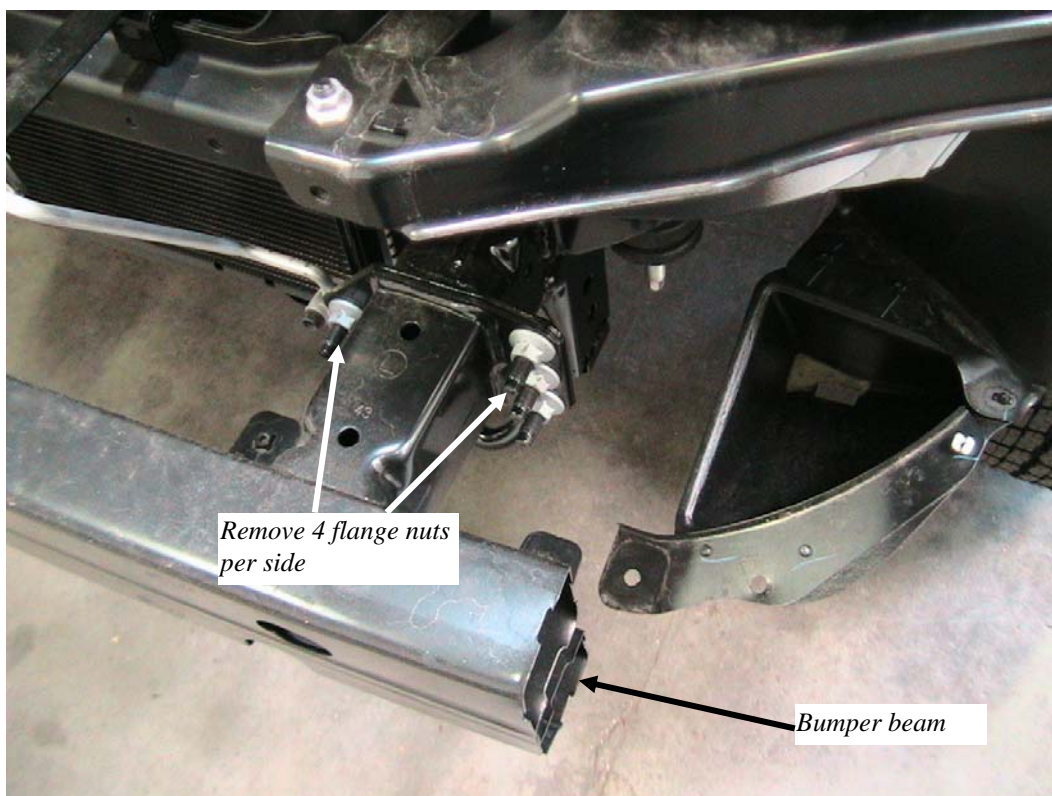

**Figure 10 Bumper beam, left side shown**

11. Remove the four screws and remove the skid pan. Retain the hardware for reinstallation of the skid pan. **Figure 11**

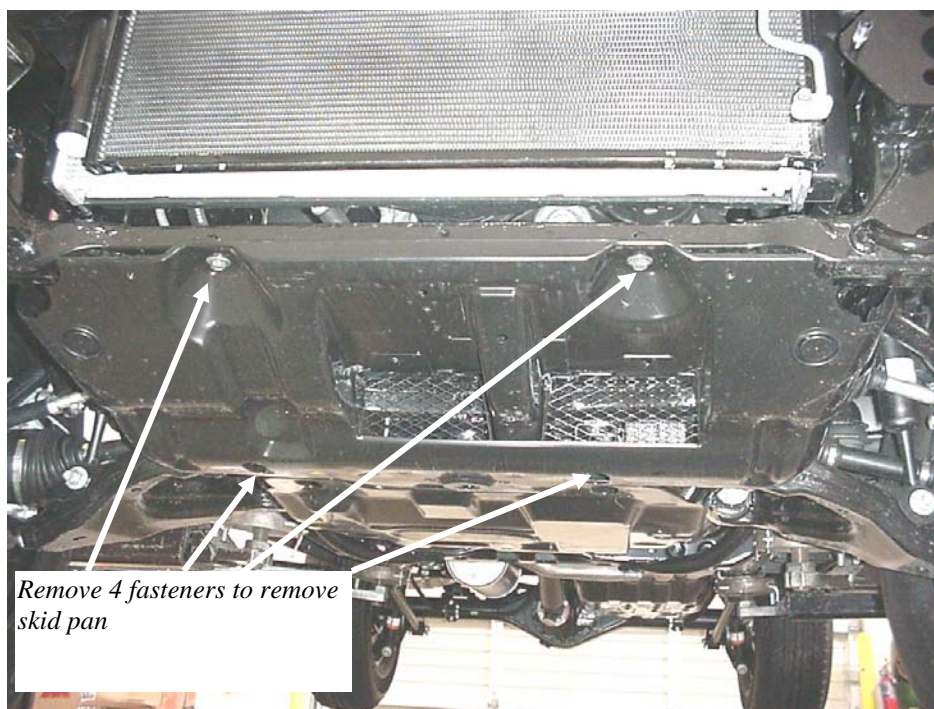

**Figure 11 Skid pan**

12. Remove the molded plastic inner fender extensions by clipping or drilling out the rivets holding them to the bottom of the inner fenders. **Figure 12**

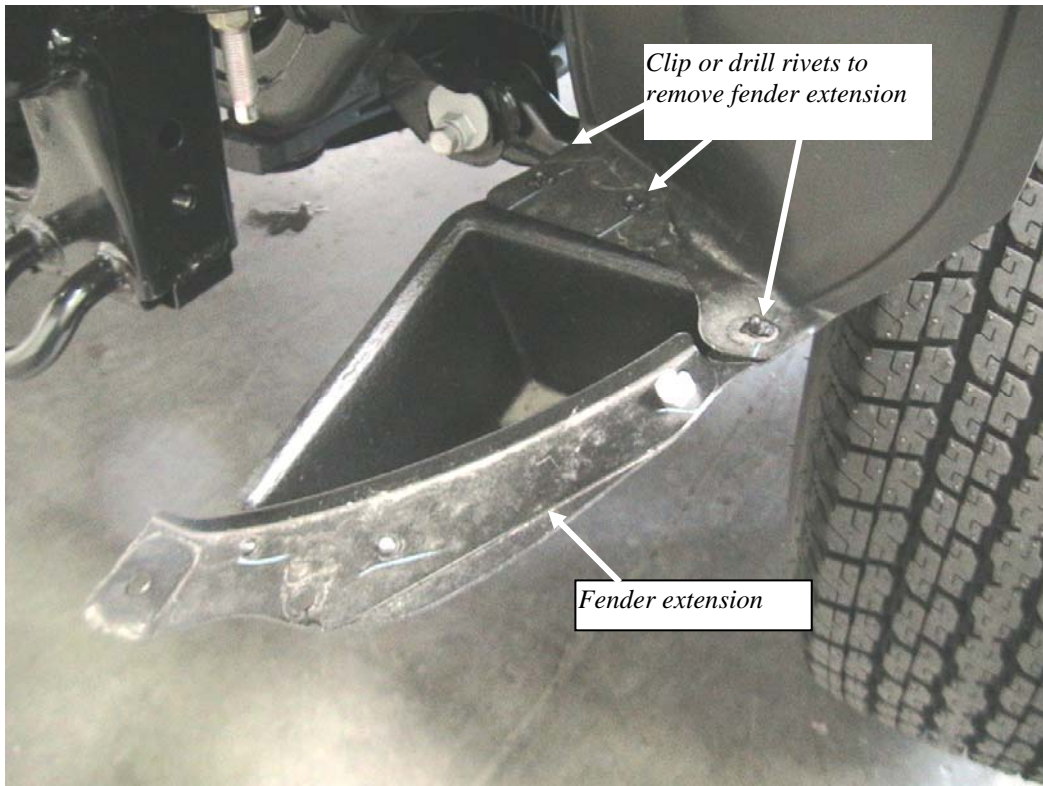

**Figure 12 Left side fender extension**

12. Locate the 1" hole in the side of the frame behind the body mount. Drill a 1/2" hole through the center into the inner wall. The Spacer Tube may be used as a centering tool. Repeat for opposite side. **Figure 13**

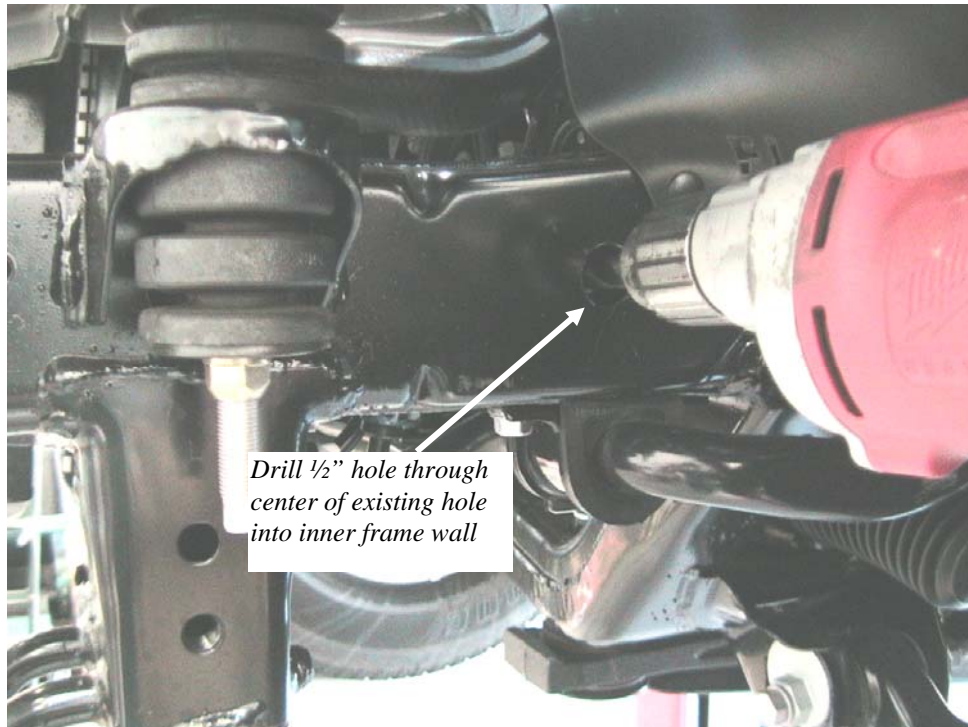
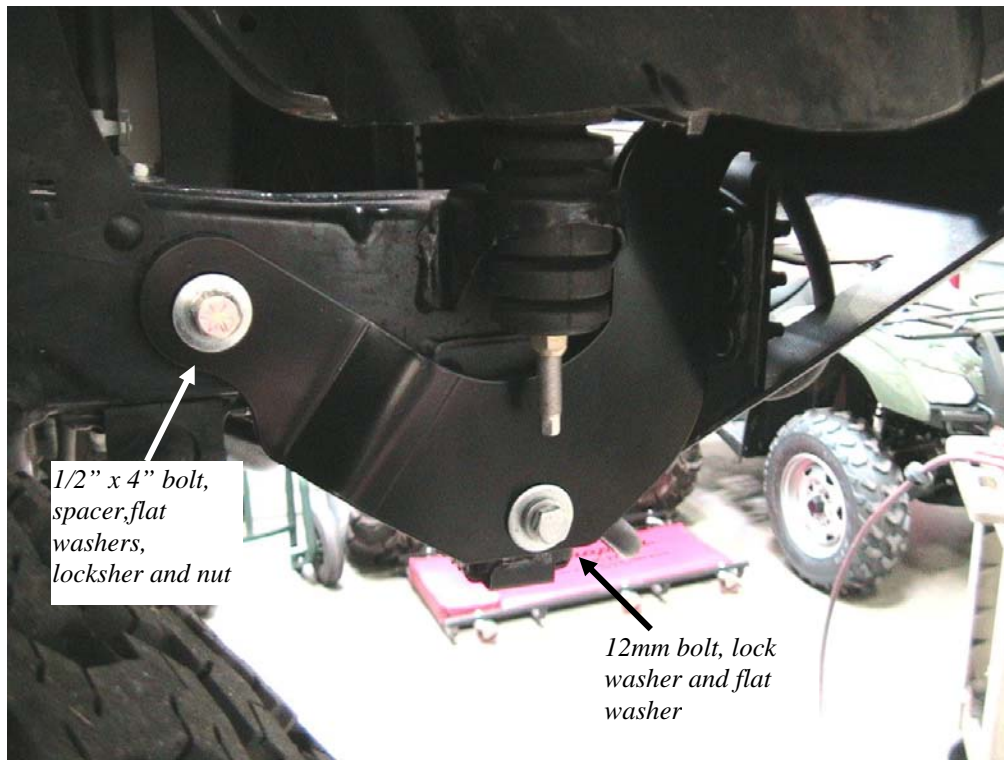

**Figure 13 Outside left frame rail**

13. Hold a Frame Bracket in position and insert a 12mm bolt with 1/2" lock washer and flat washer through the bottom hole in the Bracket and into the threaded hole in the frame. Do not tighten yet. **Figure 14**



14. Slide a 1/2" flat washer and Spacer Tube over a 1/2 x 4" bolt and insert through the Frame Bracket and Frame. Install 1/2" lock washer and hex nut. Do not tighten yet. **Figure 14**



**Figure 14 Lower Frame Bracket, right side shown**

15. Repeat steps for the other side of the vehicle.

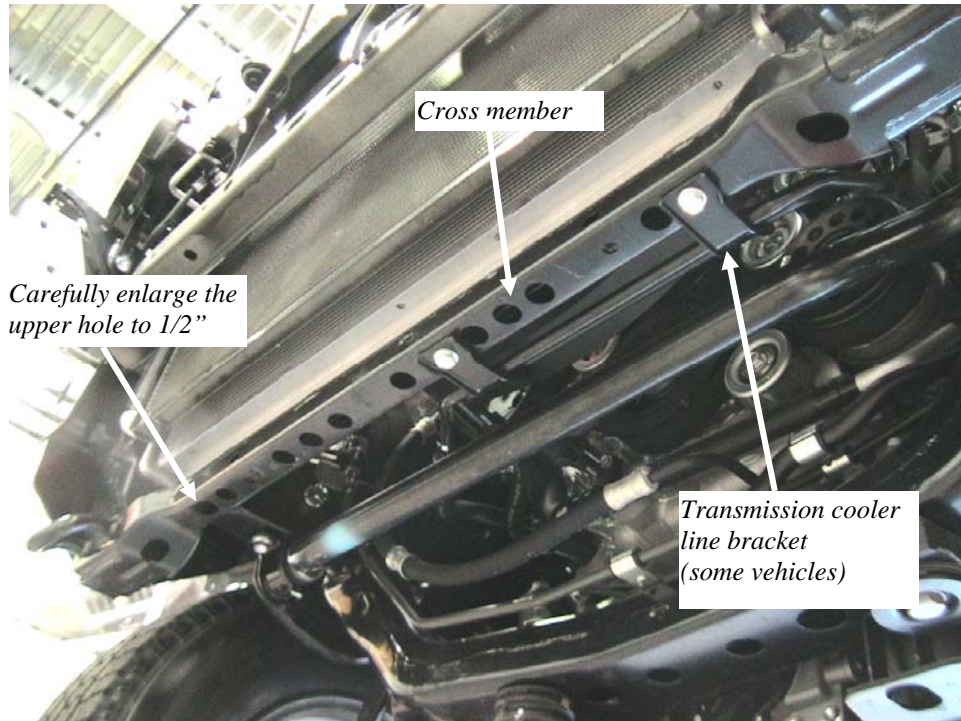
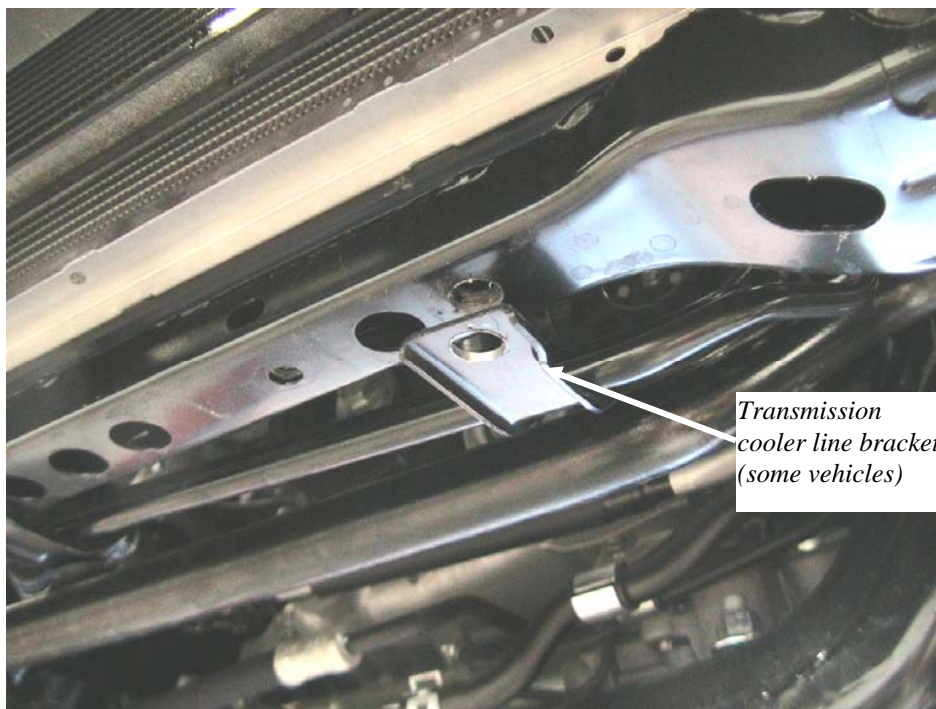

**Figure 15 Cross member**

16. Locate the outer hole in the bottom of the right end of the front cross member. Enlarge the hole in the top to 1/2". **Note: Do not drill into the radiator.** **Figure 15**

17. Locate the left outer hole in the bottom of the front cross member. This is threaded and some vehicles have a transmission cooler-line bracket bolted into it. Remove the bolt if equipped, and *carefully* enlarge

the bracket hole to 1/2". On all vehicles, drill out the threaded hole to 1/2" and continue drilling through the upper cross member wall. **Note: Do not drill into the radiator. Figure 15 and 16**



**Figure 16** Left side transmission cooler line bracket with hole enlarged to 1/2"

18. Slide the bumper onto the eight bumper beam studs. The Frame Brackets should be *outboard* of the Bumper Gusset Plates. Install the original 12mm flange nuts. Do not tighten yet.

19. Hold the RH Cross Member Bracket in place against the cross member and insert a 1/2 x 2 1/4" bolt and flat washer through the Bracket and cross member. Install a 1/2" flat washer, lock washer and nut. Do not tighten yet. **Figure 17**

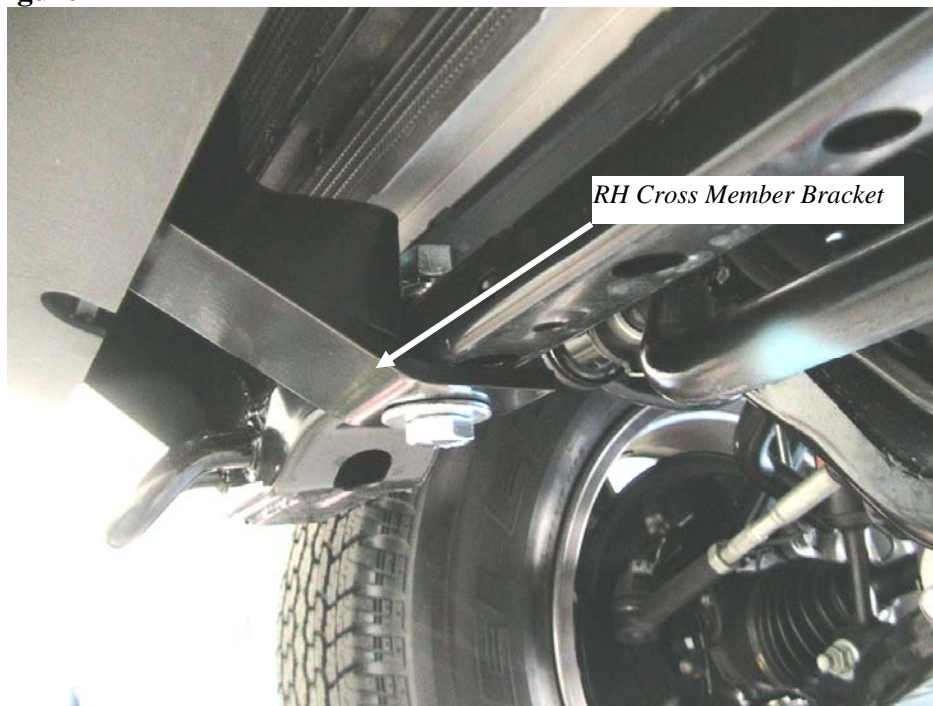

**Figure 17** RH Cross Member bracket installed

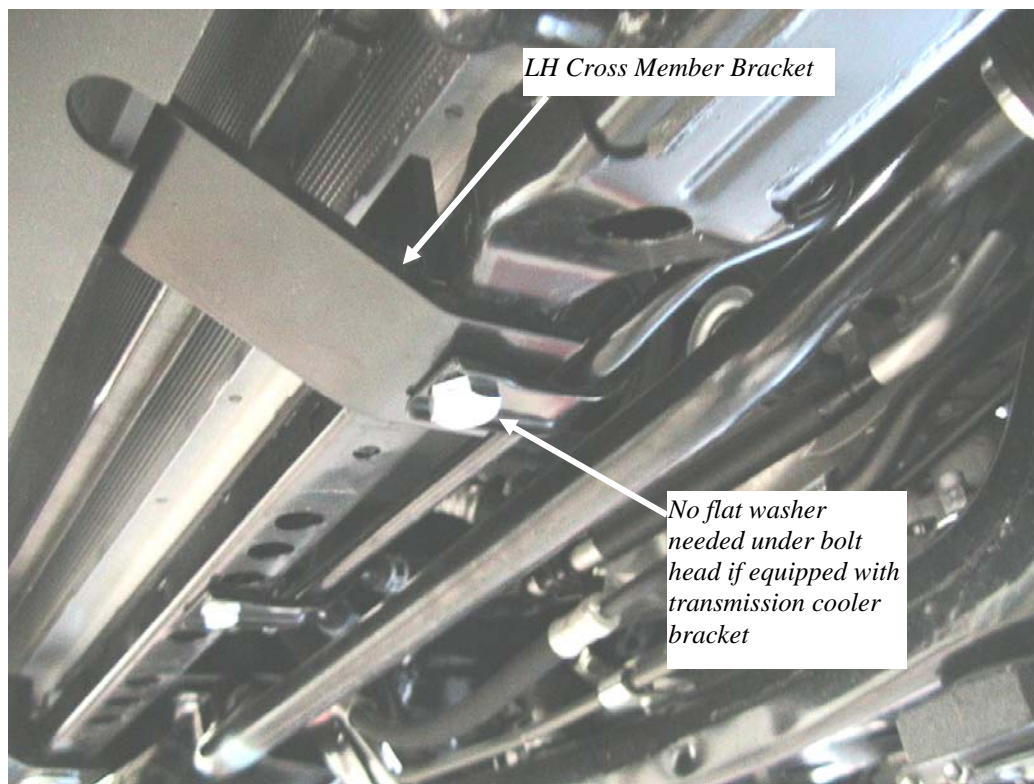

**Figure 18 LH Cross Member Bracket installed**

20. Repeat for the LH Cross Member Bracket. Position the Cross Member Bracket as shown in **Figure 18** if the vehicle is equipped with the transmission cooler line bracket. Insert a 1/2 x 2 1/4" bolt. Install a 1/2" flat washer, lock washer and nut. **Note: No flat washer is needed under the bolt head if equipped with transmission cooler line bracket.** Do not tighten yet.
21. Insert a 1/2 x 1 1/2" bolt and flat washer through the bracket into the slot in the back of the bumper. Install a 1/2" flat washer, lock washer and nut. Do not tighten yet. Repeat steps for the other Cross Member Bracket.
22. Insert a 7/16 x 1 1/2" bolt with flat washer through each of 3 slots in the Bumper Gusset Plate, into the Frame Brackets. Install a 7/16" flat washer, lock washer and nut on each. Do not tighten yet.
23. Level the bumper and tighten the eight flange nuts.
24. Tighten the 1/2 x 4" frame bolts then the 12mm Lower Frame Bracket bolt.
25. Tighten the Bumper Gusset Plate hardware.
26. Finally, tighten the Cross Member Bracket hardware. Do not over tighten the 2 1/4" bolts as this may distort the cross member.
27. The plastic inner fenders can be tucked up into the rear of the bumper and zip-tied to the body mount studs or trimmed to the desired shape. **Figure 19**
28. Reinstall the skid pan and grille with the original fasteners.



**Figure 19** Left side inner fender tucked into bumper

**Optional:**

Install the LH and RH Auxilliary Light Brackets using 7/16 x 1 1/2" bolts, flat washers, lock washers and nuts. The shape of some winches may prevent the use of these brackets. **Figure 21**



**Figure 20** RH Light Bracket installed

Install the License Plate "L" Brackets using the 1/4" hardware. The brackets can be installed from the back of the bumper. **Figure 22**



**Figure 21 License Plate Brackets installed**

**THE BUMPER INSTALLATION IS NOW COMPLETE. PROCEED TO SECTION III TITLED “MAINTENANCE/CARE”.**

**⚠ WARNING**

**READ THE VEHICLE’S OPERATOR MANUAL, WINCH OPERATOR MANUAL, AND ALL WARNING LABELS PRIOR TO OPERATION WINCH.**

**⚠ WARNING**

**FAILURE TO SECURELY TIGHTEN ALL BOLTS ON THE BUMPER, WINCH, AND FAIRLEAD CAN RESULT IN PRODUCT FAILURE WHICH MAY RESULT IN VEHICLE DAMAGE AND OPERATOR INJURY OR DEATH. DOUBLE CHECK THAT ALL BOLTS ARE SECURELY TIGHTENED PRIOR TO USE.**

**V. MAINTENANCE/CARE**

1. Inspect all parts on the winch, winch mount, and related hardware prior to each use. Replace all hardware that appears rusted or deformed.
2. Inspect all nuts and bolts on the winch, winch mount,, and related hardware prior to each use. Tighten all nuts that appear to be loose. Stripped, fractured, or bent bolts or nuts need to be replaced.
3. Check all cables prior to use. Replace cables that look worn or frayed.
4. Check all moving or rotating parts. Remove debris that may inhibit the part from moving freely.

**⚠ WARNING**

**PERFORM REGULAR INSPECTIONS ON THE WINCH, BUMPER, AND RELATED HARDWARE. NEVER OPERATE THE WINCH WITH DAMAGED OR MISSING PARTS. FAILURE TO FOLLOW THIS WARNING MAY CAUSE VEHICLE DAMAGE AND OPERATOR INJURY OR DEATH.**