



BEDLINER & TAILGATE COVER



Part No. 22106ZX, 22107X, 22107ZX, 22110X, TG05X, TG06X, TG16X



Do not over tighten as screws can be stripped out.



30-60 min

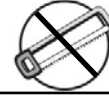

CUTTING NOT
REQUIRED



DRILLING
REQUIRED



REMOVE CONTENTS FROM BOX. VERIFY ALL PARTS ARE PRESENT.



READ INSTRUCTIONS CAREFULLY BEFORE STARTING INSTALLATION.

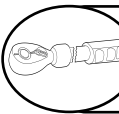

DO NOT OVER TORQUE. STANDARD OPERATING LOAD FOR TIGHTEN BODY MOUNT NUTS & BOLTS VARIES FROM 45 TO 65 FOOT POUND.

Tools Required

Phillips Head Screwdriver

Phillips Head Screwdriver, Power Screwdriver with Phillips bit

1. INSTALLATION PROCEDURE:

WARNING:

- Do not transport a pickup truck facing backward with a liner installed.
- Air can get under the liner which may result in the liner coming out of the truck and causing damage or injury.

Truck Box Preparation:

- Clean truck box of all foreign matter and open any floor drains to ensure ventilation and moisture drainage.

NOTE:

- Bed liner can be installed by one person. However, using two people is recommended by the manufacturer.

2. Dodge Tailgate Cover Installation Steps using Scrivets

NOTE: Your tailgate cover kit may have more or less hardware than shown.

STEP 1 (FIGURE 1)

Remove plastic screws (FIGURE 1A) from all Scrivet locations in the Tailgate Cover. Remove Scrivet bases (FIGURE 1B) from all Scrivet locations in the Tailgate Cover. Re-assemble Scrivet screw and base two or three threads. (Hand turn) (FIGURE 1C).

STEP2:

Place the Tailgate Cover on Truck Tailgate, lining up the holes in the plastic Tailgate Cover with the holes in the truck tailgate.

STEP 3 (FIGURE 2)

Place Scrivet Fastener in hole. PRESS DOWN FIRMLY on the Scrivet Fastener to Seat in Hole. Repeat Procedure for the 7 Other Scrivet Fasteners.

STEP 4 (FIGURE 3)

Using Phillips Screwdriver, Tighten the 8 Scrivet Screws. **DO NOT OVER-TIGHTEN. DO NOT USE POWER TOOLS.**

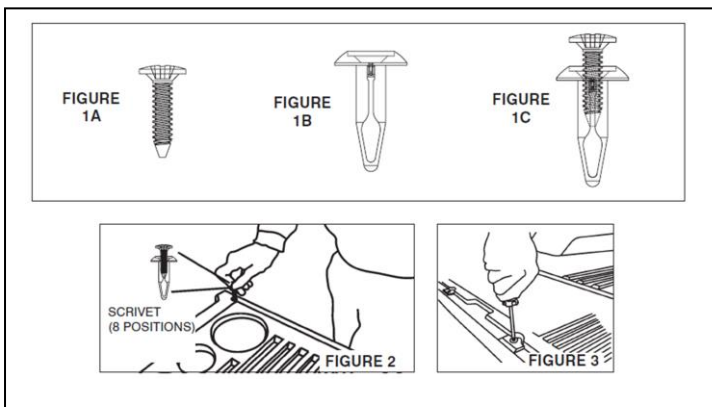

Your truck May Not use Scrivet Fasteners in your Tailgate

2A. Tailgate Cover Installation (with pre-drilled holes) without Factory Fasteners

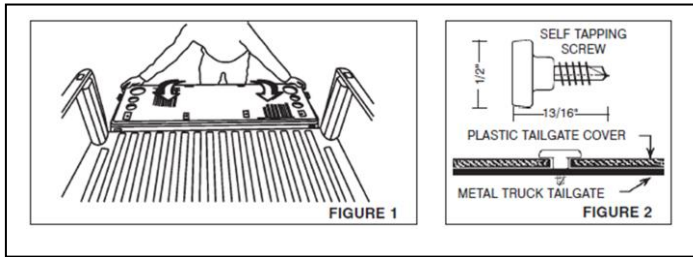

NOTE: Your tailgate cover kit may have more or less hardware than shown.

STEP 1

Center tailgate cover on truck tailgate. (See FIGURE 1)

STEP 2

Using a power screwdriver, center a self tapping screw in a pre-drilled hole in tailgate cover and fasten to truck tailgate. (See FIGURE 2)

STEP 3

Repeat Step 3 to remaining hole locations until all are completed.

2B. Tailgate Cover Installation (without pre-drilled holes) without Factory Fasteners

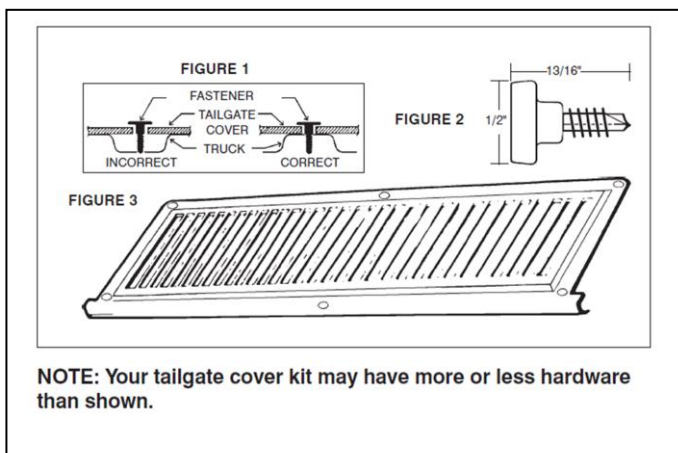

NOTE: Your tailgate cover kit may have more or less hardware than shown.

STEP 1

Center tailgate cover on truck tailgate.

STEP 2

Placement of first screw should be centered along the bottom edge of the tailgate cover.

STEP 3

Choose a location on truck tailgate which is NOT recessed, curved or obstructed (between truck ribs, over bolts, etc.). Drill a 1/8" hole through tailgate cover and steel tailgate (see FIGURE 1).

STEP 4

Drill a second 1/4" hole through first hole in tailgate cover. DO NOT drill second hole through steel!

STEP 5

Fasten tailgate cover to tailgate up to 8 places using screw shown in FIGURE 2 and following the procedure in steps 3 & 4.

2C. Tailgate Cover Installation Steps - replacing factory screws

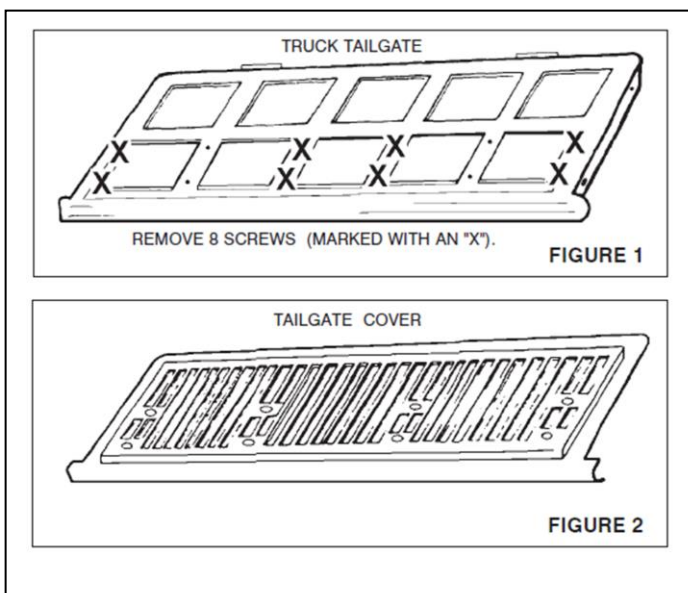

NOTE: Your tailgate cover kit may have more or less hardware than shown.

STEP 1

Center tailgate cover on truck tailgate, locating 8 factory screws at pre-drilled hole locations. Remove these screws. (See FIGURE 1) STEP 1.

STEP 2

Center tailgate cover (FIGURE 2) on truck tailgate. Line up pre-drilled holes in tailgate cover with the 8 holes in truck tailgate removed in STEP 1.

STEP 3

Using screws provided in kit, fasten tailgate cover to truck tailgate using a Phillips Screwdriver.

3. Under Rail Bedliner Installation Steps

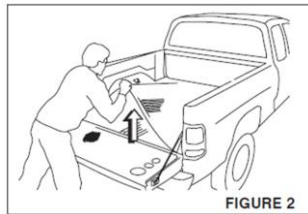
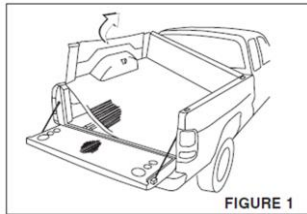

(NOTE: Some bedliners may not have front rail lip. These require two (2) screws to secure front wall.)

NOTE: Dodge Dakota Under Rail Bedliner Only

Some trucks may not use Scrivet Fasteners on the upper rear side wall. For those trucks follow use the screws supplied in the kit to fasten the upper rear side wall thru the predrilled hole.

CAUTION: It is recommended that two (2) people install the bedliner to avoid damage to the painted surface of the truck.

(NOTE The bedliner has been designed to allow for expansion/contraction in extreme ambient temperatures. Therefore it is impossible to have a perfect fit at all times.)

STEP 1 (Figure 1)

Place bedliner in the truck bed, such that the front rail retainer fits over the front rail of the truck bed. While standing on the side of the truck, lift one side of the bedliner and slip the sidewall of the bedliner under the opposite wall of truck box.

STEP 2 (Figure 2)

While standing at the rear of the truck, lift the bedliner floor in the center. (FIGURE 2) This procedure allows the bedliner sidewall to rotate away from the bed rail. Have a 2nd person slip/lock the bedliner sidewall in position by applying a downward force. **NOTE:** Make sure that the raised liner locking tabs on the sidewalls are secured behind and under the side rail sheet metal of the truck box.

STEP 3

Check the overall fit. It is important that the bedliner fits securely in place under the bed rails. If necessary, repeat steps 2 & 3.

4. Overrail Bedliner Installation Steps

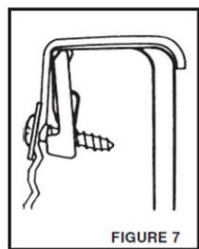
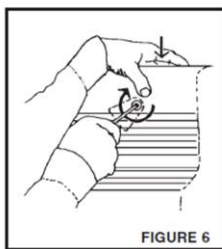
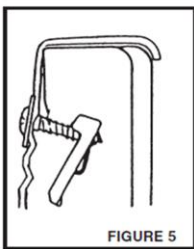
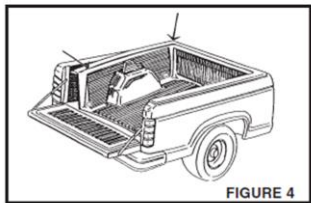
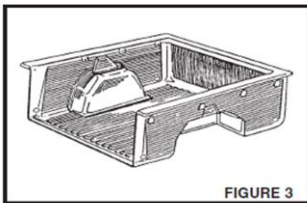
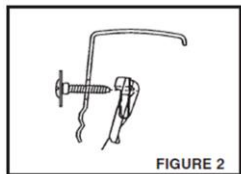
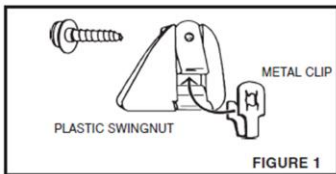

STEP 1

With the Bedliner Out Of Truck:

1. Assemble "Liner-Lok™" fasteners by sliding metal clip onto plastic swingnut (see FIGURE 1).
2. Insert screw through hole provided in bedliner side wall, with head of screw toward inside of truck bed.
3. Position "Liner-Lok™" fastener with side "A" towards screw tip (see FIGURE 2).
4. Insert screw tip into hole and metal clip of fastener and turn one or two rotations, or until tip of screw is engaged into fastener.

IMPORTANT: The "Liner-Lok™" must be in a loose downward Hanging position at this time. (see FIGURE 5)

5. Repeat "Liner-Lok™" fastener assembly to remaining holes.

STEP 2

Place bedliner with loosely hanging "Liner-Lok™" fasteners into truckbox. Pull the bedliner rails away from truck rails and push downward starting at front corner, until forward "Liner-Loks™" slip under the truck rails. Make certain that all "Liner-Lok™" fasteners have slipped under the truck rails before tightening (see FIGURES 3, 4 & 5).

STEP 3

Close tailgate. Adjust bed liner if needed.

STEP 4

Standing or kneeling on bedliner in truck box:

1. Start at either front (cab end) corner and push downward on bedliner rail while turning screw clockwise with screw driver (see FIGURE 6). You should "feel" the "Liner-Lok™" pivot upwards and stop. Continue turning the screw clockwise until tight (see FIGURE 7).
2. Move to opposite corner and repeat step 4 - 1.
3. Repeat step 4 - 1 to remaining "Liner-Loks™".

PRODUCT CARE

- Sweep any dirt and debris out of the bed of the truck. Pick up any items that may scratch the liner, such as rocks or large sticks.
- Inspect Bed liner on frequent basis to identify any damages.
- Clean the product with mild soap / cleaner to remove stains.
- While washing Rinse bed and tailgate thoroughly until no soap runs off the truck.

FAQ's

1. **Will the bed feel hotter than the rest of the truck?**
No, protective coating shall help to keep it cooler than truck.
2. **Protective coating is used as an undercoating?**
Yes, it can be used.
3. **Is protective coating environmentally friendly?**
Yes, there is no possible health hazard and it is environment friendly
4. **Can I take it out Protective Coating?**
No, Protective coating is a permanent coating and can't be removed.
5. **Does the lining require special maintenance?**
No, it can be cleaned up with mild soap.
6. **Missing / Excess Hardware.**
Recheck hardware count as per the part list.
7. **Product not installing properly.**
Ensure make model year, cab length and bed size of your vehicle is listed in the application. All installation steps are followed correctly.