

PARTS INCLUDED

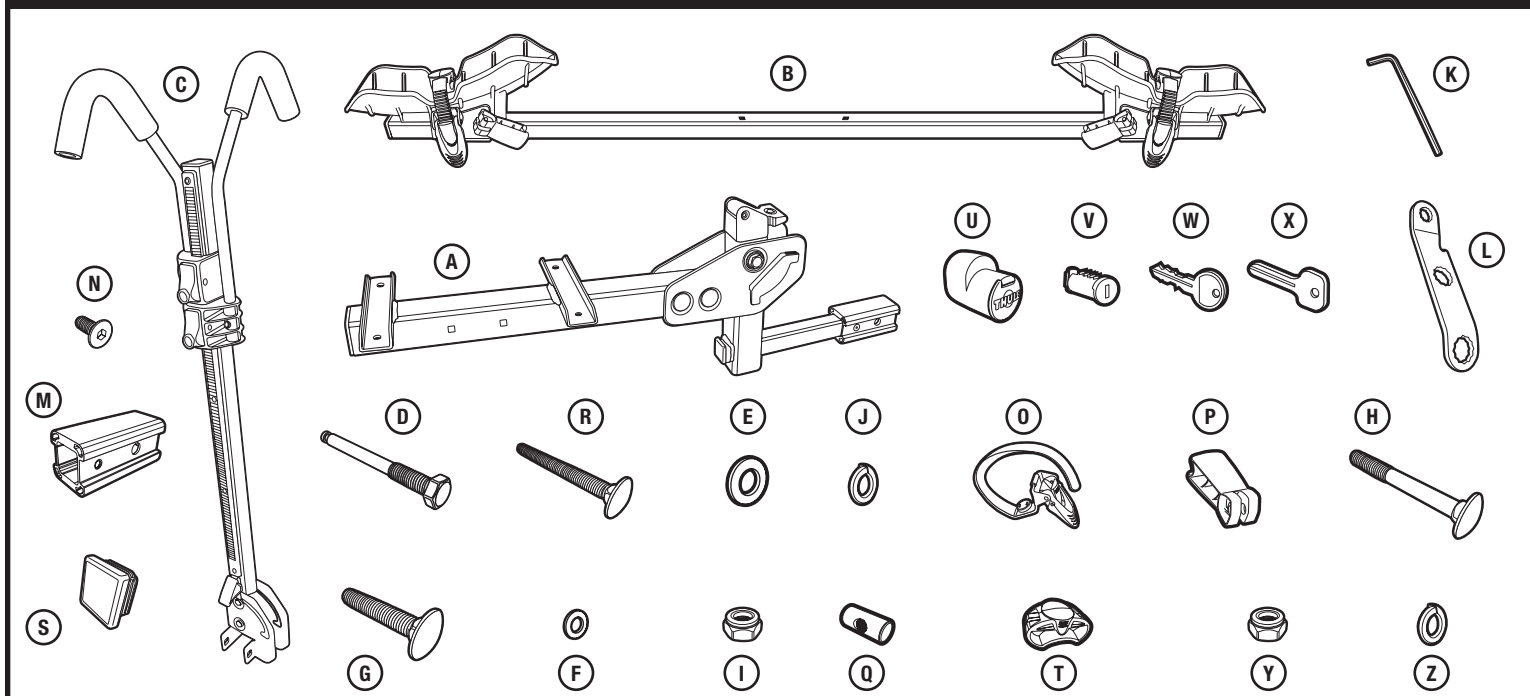

part	description	part number	qty.
A	stinger & backbone assembly	—	1
B	bike tube & wheel holder assembly	7533928	2
C	upright tube & hook assembly	7533929	1
D	STL2 hitch lock pin	8535917	1
E	washer 12mm x 24mm	951122411	1
F	washer 8mm x 16mm	951081611	6
G	carriage bolt M8 x 45mm	915084531	4
H	carriage bolt M8 x 70mm	915087031	2
I	locknut M8	938080011	2
J	lock washer 12mm	956122111	1
K	hex key 4mm	853243002	1
L	Thule hitch tool	8535524	1
M	adapter sleeve, short	8537489	1
N	flat cap screw M6 x 16mm	853578702	1
O	wheel strap assembly	7533001	4
P	lever / levier / palanca	8533506	4
Q	axle nut 18mm	8530446	4
R	carriage bolt M6 x 60mm	915066031	4
S	end cap 1.25" square	8537484	4
T	road bike adapter	8535426	4
U	STL2 hitch lock	753372502	1
V	lock cylinder	—	3
W	locking key	—	2
X	change key	8531251	1
Y	hex nut M8	936080011	4
Z	lock washer M8	956081411	4

WARNINGS / LIMITATIONS

- Fits 20-29" wheels up to 3" wide
- 2 Bike maximum carrying capacity = 70lbs.
- Carries bikes with wheel bases up to 46.5"
- The 990XT Doubletrack™ can work with bikes with tire fenders.

1

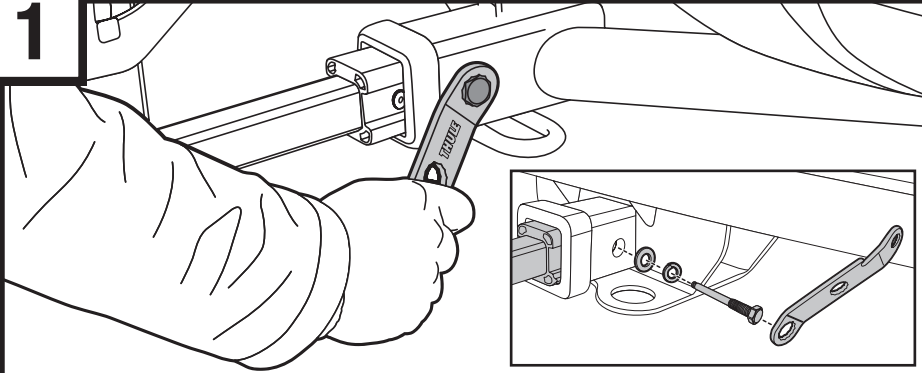

- Slide hitch into trailer hitch receiver until hole in horizontal tube aligns with receiver hole. Secure in position with STL2 receiver bolt (D), lock washer 12mm (J), and washer 12mm x 24mm (E) as illustrated. Tighten firmly with Thule hitch tool (L).

FOR 1 1/4" INSTALLATION

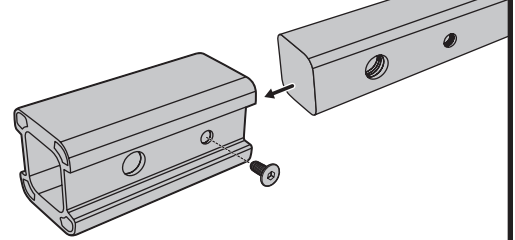

- Remove adapter sleeve, short (M) using hex key 5mm (K) provided, as illustrated.

2

SECURE UPRIGHT ASSEMBLY

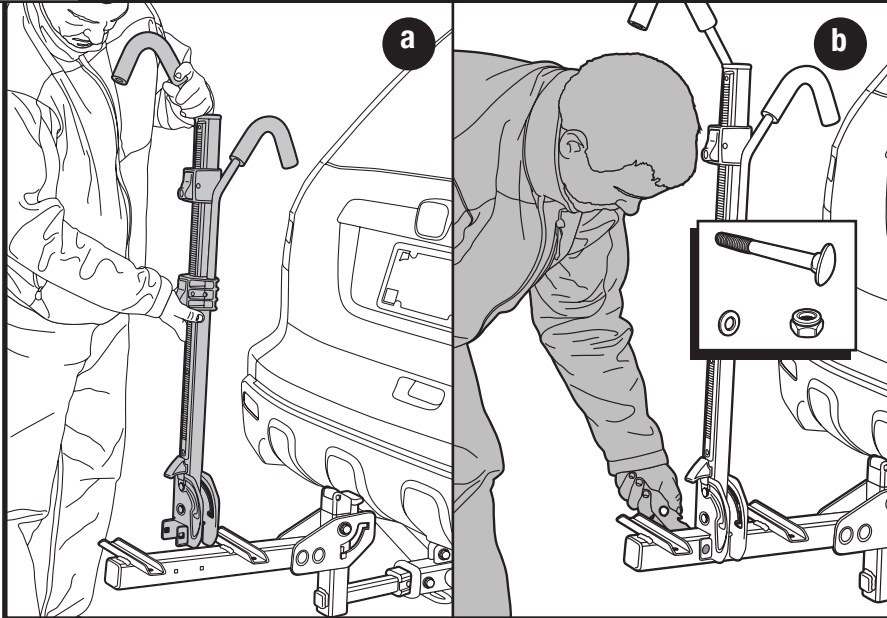

- a Align upright tube & hook assembly (C) mounting holes with holes on the sides of the stinger & backbone assembly (A).
- b Secure with M8 x 70mm carriage bolts (H), washer 8mm x 16mm (F), and locknut M8 (I) as illustrated. Tighten firmly with Thule hitch tool (L).

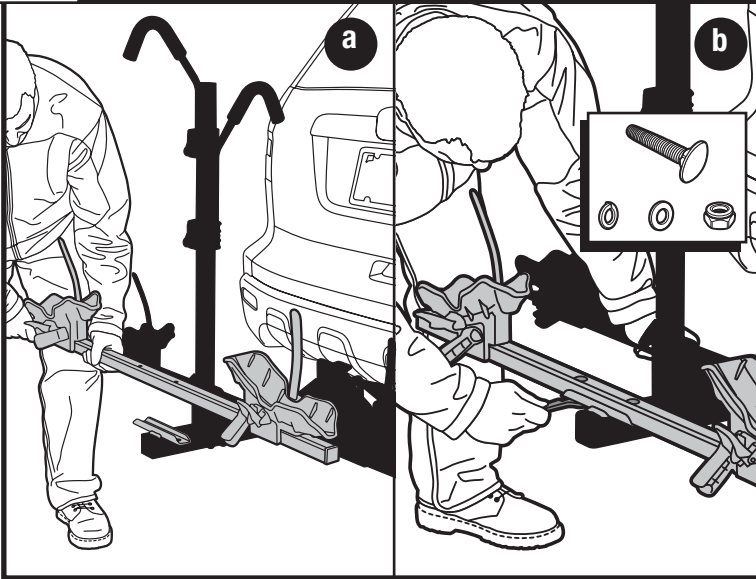
3**SECURE BIKE CARRIER TUBES**

- Place bike tube & wheel holder assemblies (B) centered on tray of stinger & backbone assembly (A).
- Align bike tube holes with holes on base unit and secure with M8 x 45mm carriage bolts (G), washer 8mm x 16mm (F), lock washer M8 (Z) and hex nut M8 (Y) as illustrated. Tighten firmly with Thule hitch tool (L).

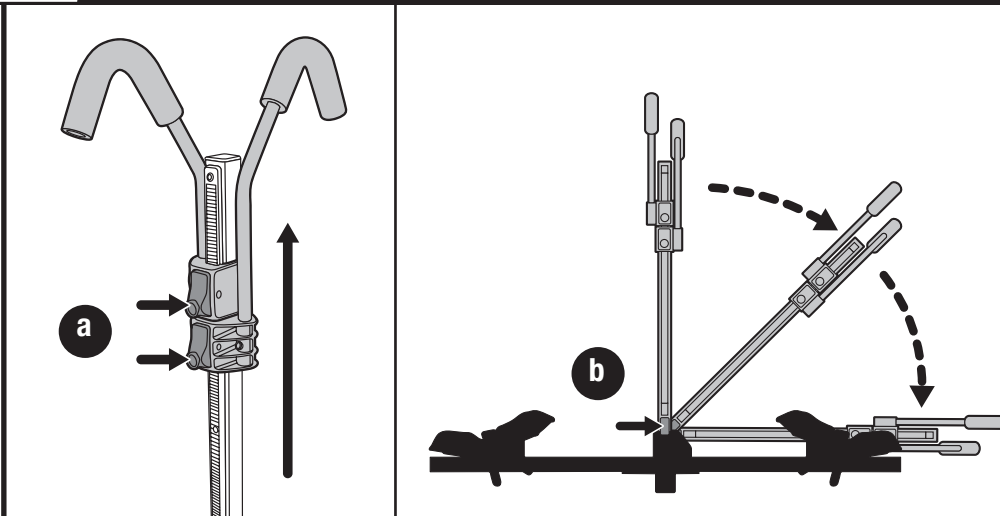
4**LOADING BICYCLE**

a Press release-button on upright tube & hook assembly (C) and raise up the hooks as far as possible.

b Lift upright release lever and rotate upright to down position.

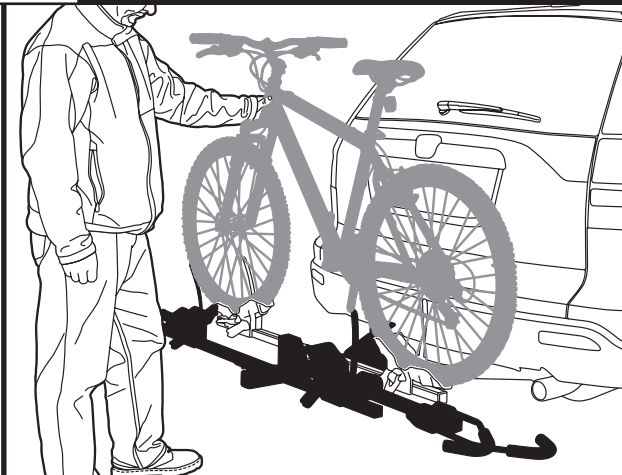
5**LOADING BICYCLE**

- Place smaller bike on inner carrier with wheels in wheel holders and handlebars to left side of vehicle.

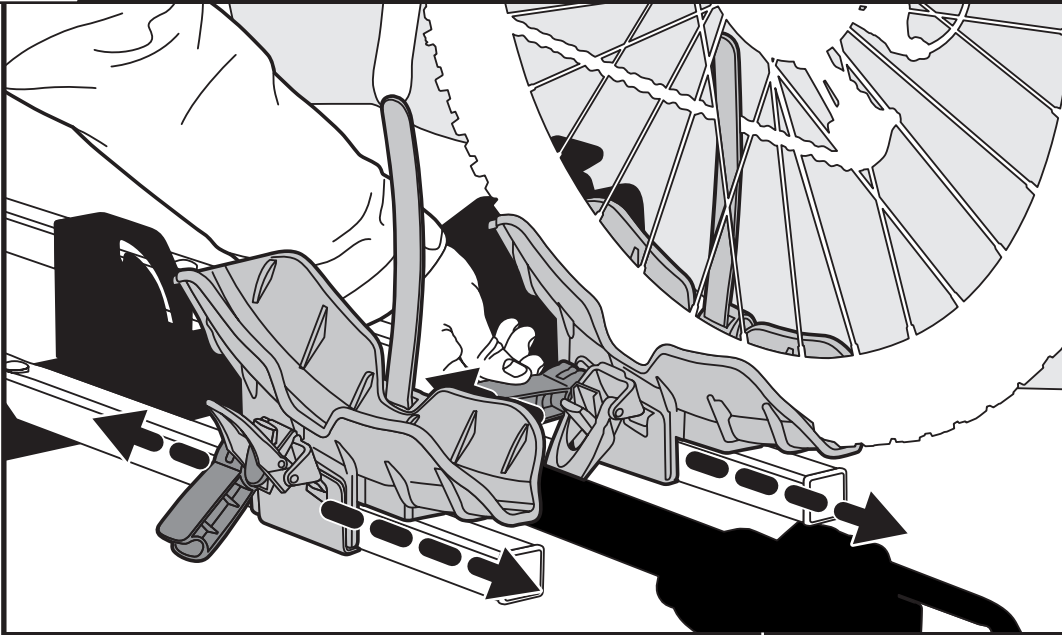
6**LOADING BICYCLE CONTINUED**

- With cam lever in open position, position wheel trays on tube. Move cam lever to closed position to tighten wheel tray in position.

Road bike only

- Slide on adapter onto strap.

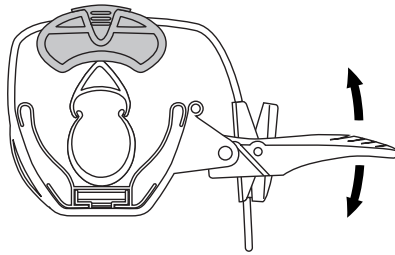
**Mountain bike only**

- Invert or remove for mountain bikes.

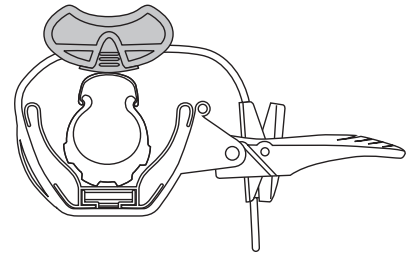

NOTE: Thread wheel strap through buckle. Then push down to close buckle. You may have to open buckle and adjust strap length for a tight closure.

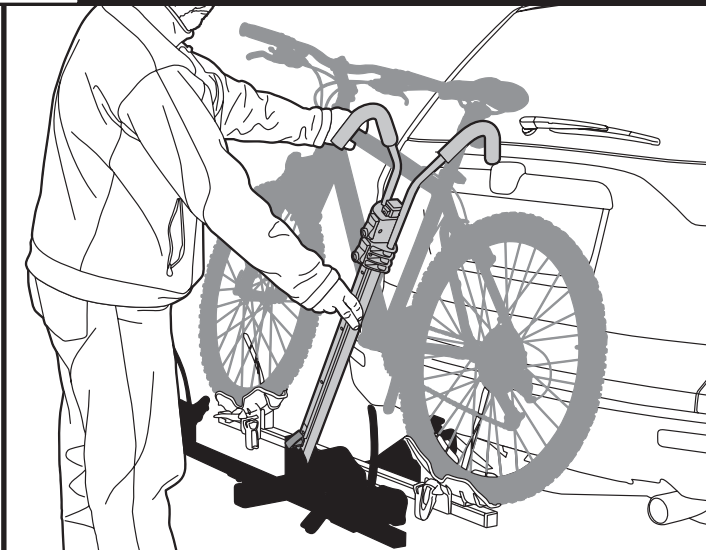
7**LOADING BICYCLE CONTINUED**

- Lift upright tube release latch and raise upright tube and hook assembly until it clicks into position.

NOTE: You may need to tilt bike towards vehicle for clearance.

- Push bike hook down with firm pressure until it is secure on the bike's top tube.

8

LOADING BICYCLE CONTINUED

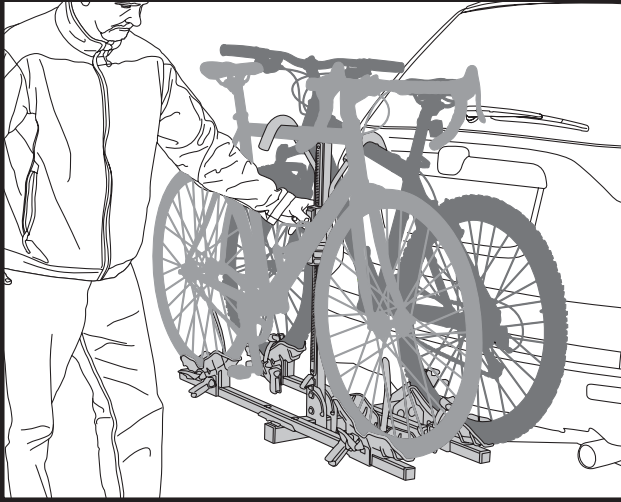

- Load second bike with handle bars to the right side of vehicle.
- Secure bike with bike hook and wheel straps.

9

FOLDING UP THE RACK ON VEHICLE

a With bikes unloaded, rotate upright tube & hook assembly (C) into down position.

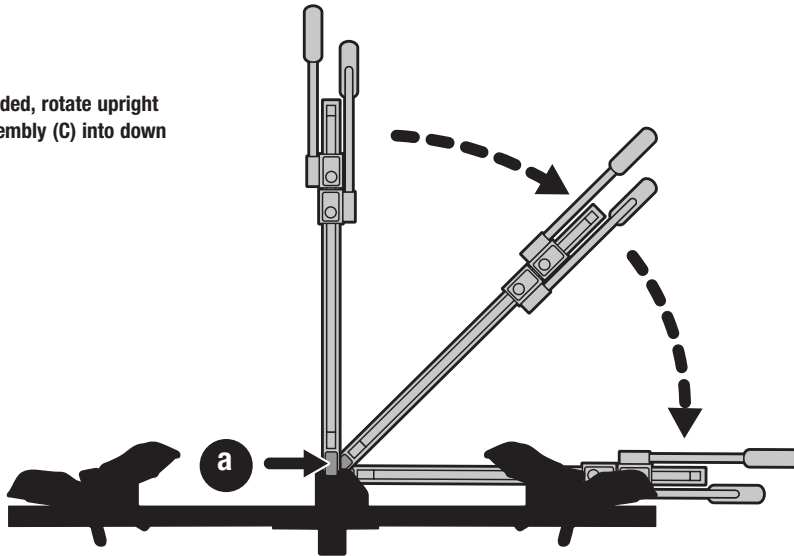

b

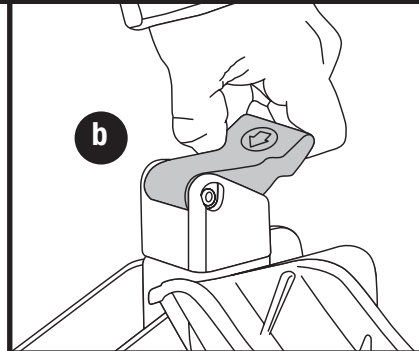

b Lift lever on Hitch Switch as illustrated.

c

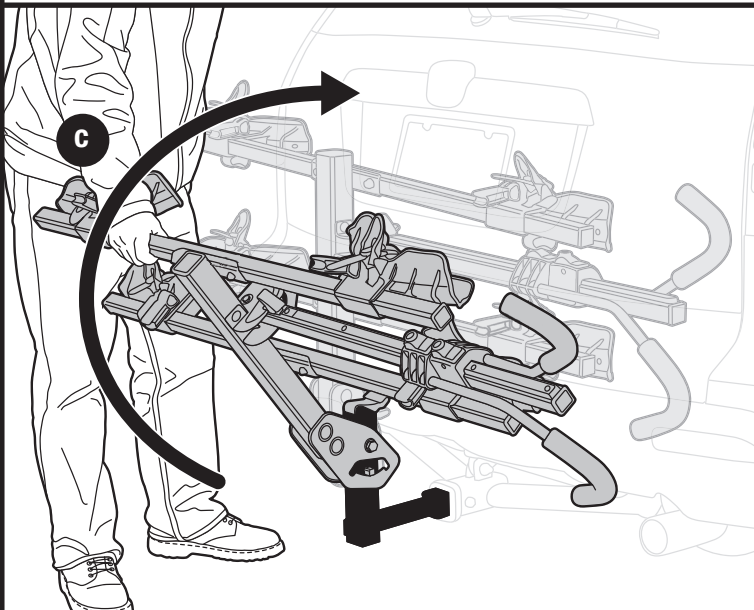

c With other hand, lift bike carrier assembly upward until the Hitch Switch lever clicks into locked position.

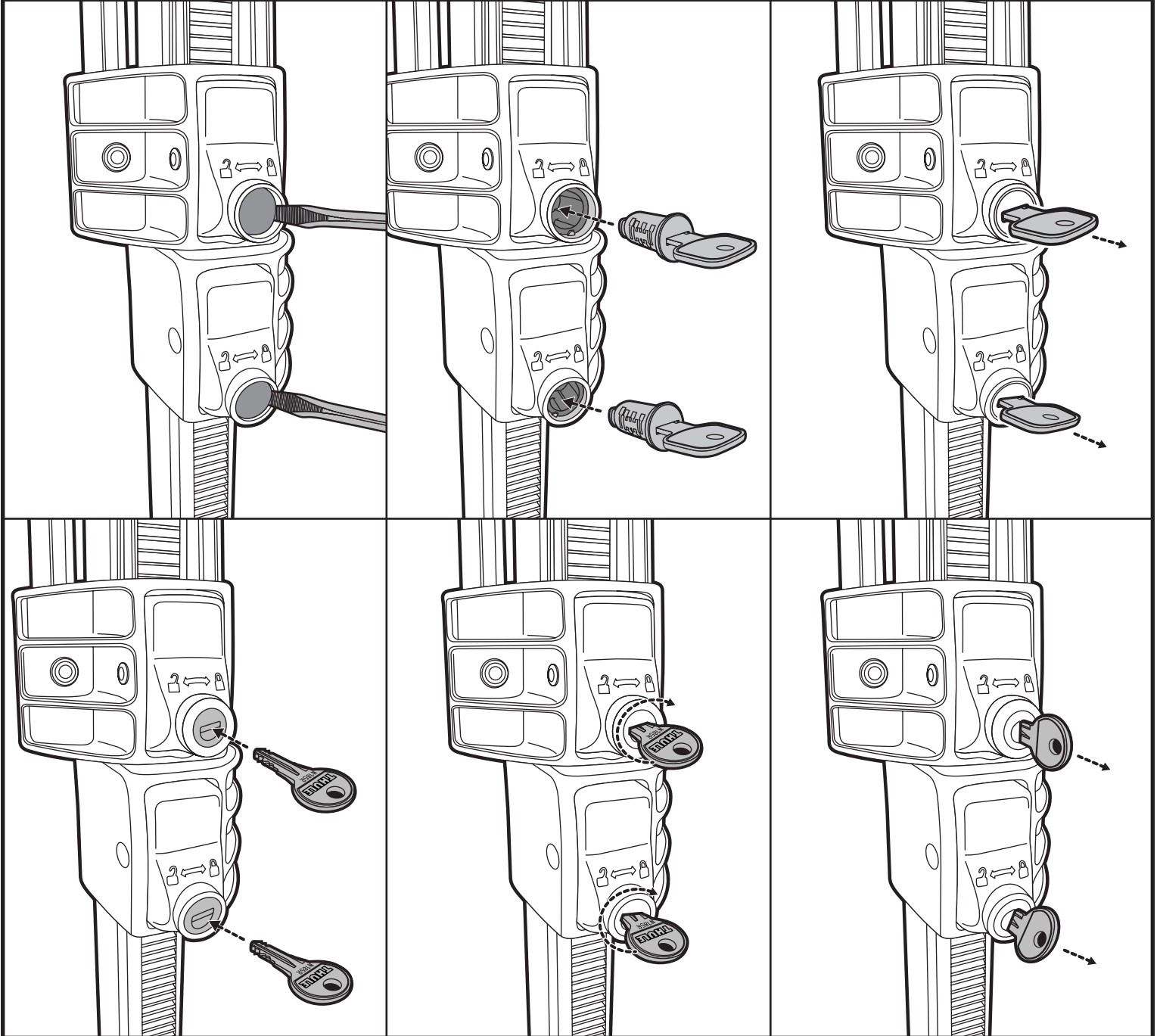

Thule strongly recommends the use of locks to deter theft. As shown, follow these easy steps for installing the lock cylinders.

Using a flat head screw driver, first remove the black plug caps from the ratcheting hook bases. Then insert the change key into the lock cylinder and slide the lock cylinder into the round slot as shown. Remove change key. To lock, insert locking key and turn clockwise.

LOCK CYLINDER INSTALLATION FOR STL2

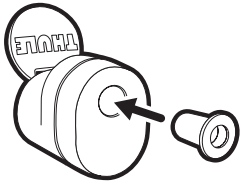

a. Remove and discard plug.



b. Open cover.

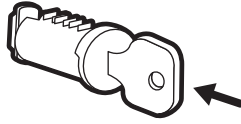

c. Insert change key into lock cylinder

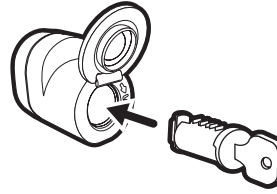

d. Insert cylinder into STL2 lock housing.

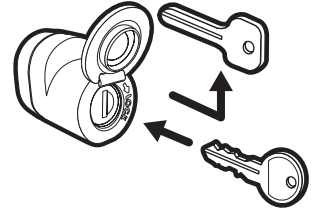

e. Remove change key. Insert locking key.

INSTALLATION OF STL2

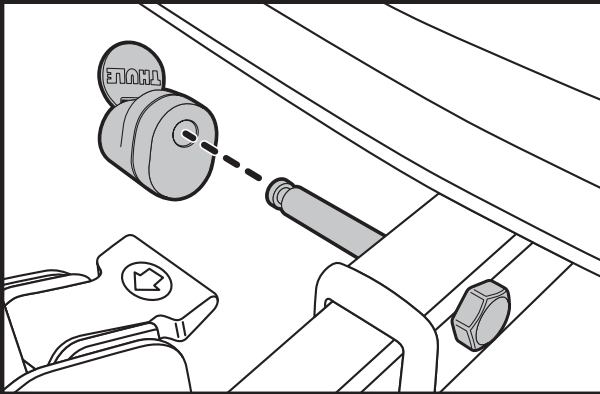

- Slide STL2 onto hitch pin, keeping key vertical.
- Turn key clockwise to lock, remove key.
- Close cover.