

Installation Instructions

Electric Trailer Brake Control Wiring Adapter



ENGLISH

1. Locate the vehicle's electric brake control harness. The harness will be located under the dash near the center console on most vehicles. The harness for the Ford Full Size Van is located underneath and left of the steering column. The harness for the Ford Explorer/Mercury Mountaineer is located behind the vehicle glove box on the Passenger side or the harness will be located underneath and left of the steering column, taped to another harness near the emergency brake pedal. There will be a 6-pin connector that mates with the one on the adapter at the end of the harness.
2. Verify that there is battery power supplied to the connector by carefully probing the connector with a test light. This can also be accomplished by following the wires to their source, ensuring they do not dead end without connections behind the instrument panel. For vehicle's with power supplied at this connector, proceed to Step 4.
3. For vehicles with no power to the electric brake control connector: Using an electric brake control wiring kit, route all wires as described in the wiring kit installation instructions. Cut the vehicle connector's battery feed wire, allowing enough wire remaining to connect the battery wire from the brake control wiring kit using the butt connector supplied. Cut the vehicle connector's trailer brake wire, allowing enough wire remaining to connect the trailer brake wire from the wiring kit using the supplied butt connector.

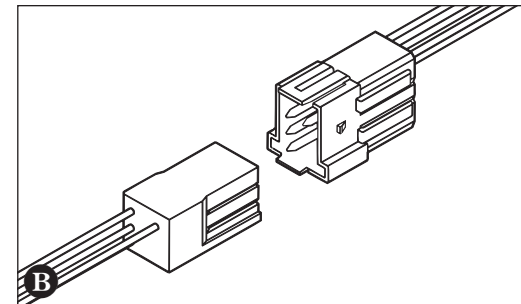
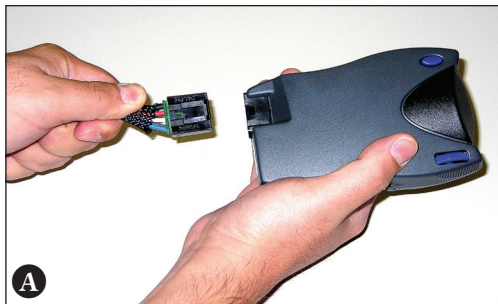

TRAILER BRAKE
CONTROLLER (OUTPUT)

GROUND

VEHICLE STOP LAMP
SWITCH TO BRAKE
CONTROLLER (INPUT)

HEAD LAMP
SWITCH TO VEHICLE
RUNNING LAMPS
(UNUSED)

FUSED TRAILER BRAKE
CONTROLLER BATTERY FEED

4. Plug the brake control adapter into the vehicle's electric brake control harness connector. Follow all brake control manufacturer's installation instructions **B**.