

Pyrometers



Gauges & Senders



**TECTRAN**  
...Making the Right Connections



# Instrument Gauges

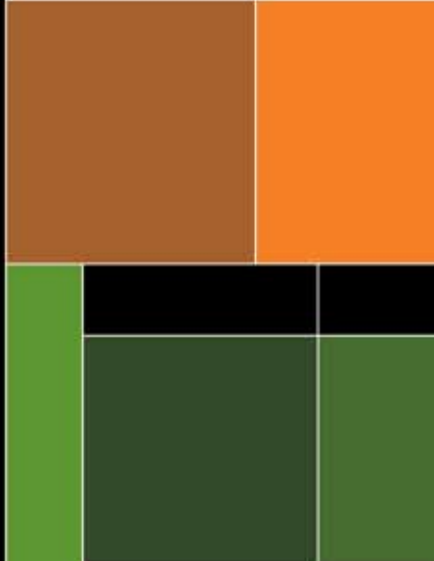

Specialty  
Products

Tachometers &  
Speedometers



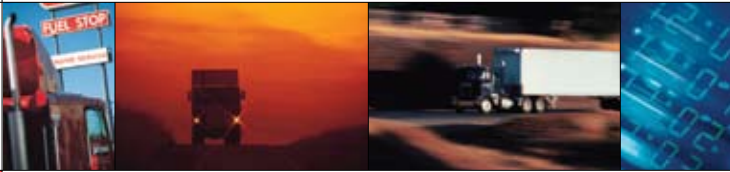

For over 30 years TECTRAN has been known as a problem-solver in the mobile equipment industry. Our unique air and electrical hookup lines and other “connections” products reduce maintenance costs and downtime. Industry-leading order fill rates enable parts marketers and end users to get what they want when they want it. Our broad product offering allows you to consolidate orders and reduce the number of suppliers to deal with. Teaming up with other specialized high quality manufacturers of “maintenance solutions” products has helped TECTRAN fulfill these needs even better.



We are very proud to introduce this complete new line of instrument gauges. Many of the items shown here are in stock and available to ship immediately with orders of other Tectran products. As always, TECTRAN stands behind the quality of all the products that we supply, and we’re here to answer your questions and hear your suggestions about this exciting new line.

At TECTRAN, we believe in simplifying life, so on each package label we’ve included interchange numbers to other leading manufacturers’ products. Most gauges are packed in window cartons which allow you to see the contents.



In addition to the many industry-standard gauges depicted here, we wish to draw special attention to the excellent maintenance value of the pyrometer systems covered in the separate catalog section beginning on page 11. A pyrometer, which measures exhaust temperature, will provide an early indication of engine problems, better fuel efficiency and lower emissions.



Please take note of our tube-style ultimate fuel level senders shown on pages 9 & 10. These state-of-the-art fuel level monitoring devices are becoming the industry standard, replacing the traditional float-arm style senders used in the past.



# Table of Contents

## Gauges & Senders

1 - 10



Oil & Drive Pressure - Mechanical	2
Air & Dual Air Pressure - Mechanical	2
Axle Load - Mechanical	2
Fuel, Manifold & Turbo Boost - Mechanical	3
Vacuum & Vacuum/Turbo Boost - Mechanical	3
Water & Oil Temperature & Gauge Panel Kits - Mechanical	4
Oil Pressure & Fuel Level - Electrical	5
Ammeters & Voltmeters - Electrical	6
Air & Fuel Pressure - Electrical	6
Temperature - Electrical	7
Senders - Pressure, Temperature, Fuel Level	8-10

## Pyrometers

11 - 17

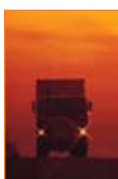

2 1/6" Pyrometers	12
Digital Pyrometers	13
2 3/4" Pyrometers	13
3" Pyrometers/Specialty Pyrometers	13
3" Turbocator	13
Pyrometer Basics	14
Lead Wires	15
Thermocouples	15
Thermocouple Accessories	16
Pyrometer Tester	16

## Speedometers & Tachometers

18 - 25



Mechanical Speedometers	19
Programmable Speedometers	19
Magnetic Sensors & Signal Generators	21
Mechanical Tachometers	21
Speedometer & Tachometer Cable Parts	22
Interconnect Harnesses	22
Programmable Tachometers	23
Electronic Tachometers	24
Alternator Tachometers	24
Hand Held Tachometers	24
Ignition Tachometers	25
Specialty Devices	25
Product Specifications	25

## Specialty Products

26 - 31



Engine Shutdowns	27
Turbo Temp Monitors	27
Low Water Alarms	27
Electronic Speed & Exhaust Temperature Switches	28
Pressure & Temperature Switches	28
Hourmeters	29
Heavy Duty Voltmeters & Ammeters	29
Gauge Mounting Accessories	29
Lighting, Relays, Buzzers & Alarms	30
Adapter Bushing Kit	30
Water Level Probes & Warning Lights	30
Voltage Reducers	31
Tubing Kits & Adapter Nuts	31
Black Ice Indicator Gauge	31

## Index

32

# Gauges & Senders

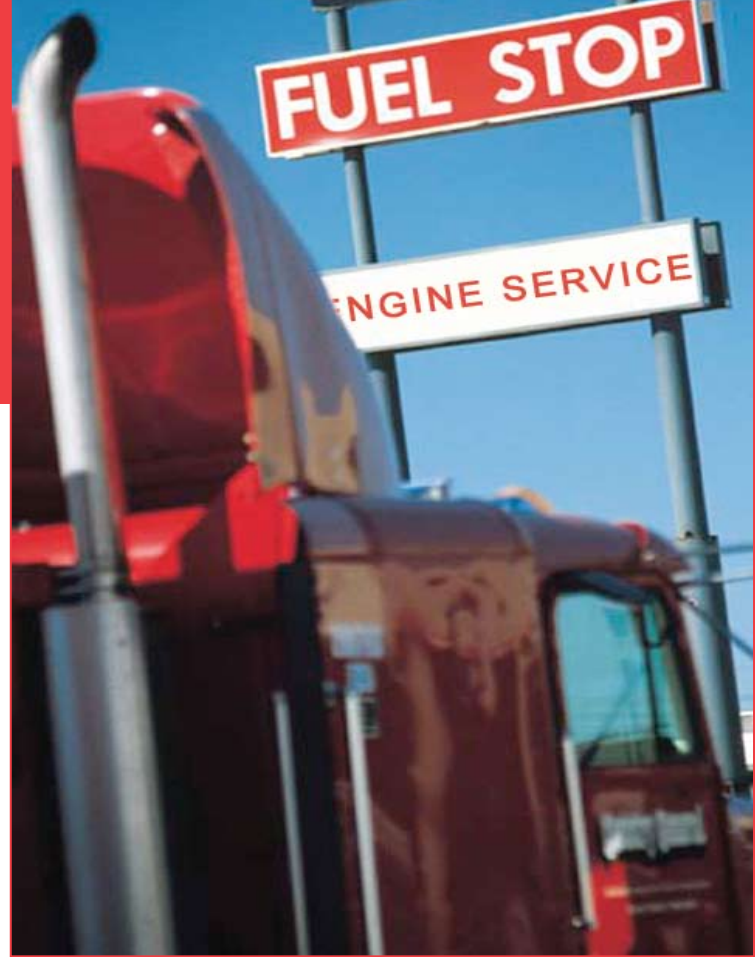

## All gauges offered in this section have the following features:

- Industry standard 2 1/16" mounting diameter
- Bright chrome or black brass bezels
- Silicone dampened air core movement for steady readings and vibration resistance.
- Knurled mounting nuts for easy installation.
- Glass filled nylon case resists corrosion and vibration.
- Water resistant lenses are glass, not plastic, so they are scratch resistant.
- Plated mounting hardware prevents corrosion.
- Mechanical gauges use precision hobbled brass gears for long life.
- 12 VDC NG operation. Consult factory for 24 VDC NG applications.
- Mounting hardware and light kit with 12 VDC light included.
- White pointer is standard except on english/metric gauges.
- English/metric gauges have red-orange pointers and dual scales.
- Bright, attractive packaging improves product visibility on display.
- Consult factory for positive ground applications.

## Contents

### Mechanical Gauges

- Oil & Drive Pressure
- Air & Dual Air Pressure
- Axle Load
- Fuel, Manifold & Turbo Pressure
- Vacuum & Vacuum/Turbo Boost
- Water & Oil Temperature & Gauge Panels

### Electrical Gauges

- Oil Pressure & Fuel Level
- Ammeters & Voltmeters
- Air & Fuel Pressure
- Temperature

### Senders

- Pressure, Temperature, Fuel Level

## 2 1/16" Mechanical Gauges

Mechanical gauges sense pressure or temperature through tubing that transmits this information. Electrical power is required for operation of night lighting only. Senders are not needed for mechanical gauges. Mechanical gauges, categorized by type, are shown on pages 2-4. All mechanical gauges have a 270° sweep.

### 2 1/16" Oil Pressure & Drive Oil Pressure Gauges

Requires pressure tubing kit for installation. For details, see page 31 of this catalog.

BLACK BEZEL	CHROME BEZEL	ENGLISH SCALE	METRIC SCALE
95-2235	95-2236	25-400 psi	170-3000 kPa
95-2230	95-2231	25-400 psi	N/A
N/A	95-2232	20-300 psi	N/A
N/A	95-2209	10-200 psi	N/A
95-2216	95-2221	5-100 psi	35-700 kPa
95-2201	95-2207	5-100 psi	N/A
95-2215	N/A	5-80 psi	35-550 kPa
95-2200	95-2206	5-80 psi	N/A
95-2202	95-2208	2-50 psi	N/A



95-2200 2 1/16" Oil pressure gauge  
2-50 psi scale, black bezel



95-2221 2 1/16" Oil pressure gauge  
english/metric scale, chrome bezel



95-2216 2 1/16" Oil pressure gauge  
english/metric scale, black bezel

### 2 1/16" Air Pressure & Dual Air Pressure Gauges

BLACK BEZEL	CHROME BEZEL	ENGLISH SCALE	METRIC SCALE
95-2270	95-2272	10-150 psi	N/A
<b>DUAL AIR PRESSURE</b>			
95-2285	N/A	10-150 psi	0-1050 kPa
95-2280	95-2282	0-150 psi	N/A

All dual air pressure gauges have metal cases and two pointers; top pointer is white, bottom pointer is red-orange.



95-2232 2 1/16" Drive oil pressure gauge  
10-200 psi scale, chrome bezel



95-2282 2 1/16" Air pressure gauge  
10-150 psi scale, chrome bezel



95-2280 2 1/16" Dual air pressure gauge  
english/metric scale, black bezel, two pointers

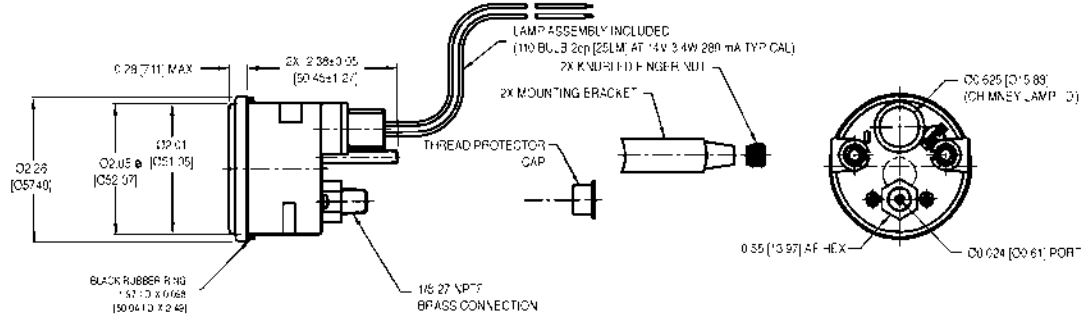

Typical view of a 2 1/16" air pressure gauge

### 2 1/16" Axle Load Gauges

BLACK BEZEL	CHROME BEZEL	SCALE
N/A	95-2335	5,000-55,000 lbs
N/A	95-2336	7,500-45,000 lbs

Lights not provided with gauge. If lights are needed order 95-6202.



95-2335 2 1/16" Axle load gauge  
5,000-55,000 lbs scale, chrome bezel, red-orange pointer



95-2345 2 1/16" Fuel pressure gauge 0-100 psi scale, black bezel



95-2349 2 1/16" Fuel pressure gauge 2-30 psi scale, chrome bezel



95-2301 2 1/16" Manifold pressure gauge 2-30 psi scale, black bezel, red-orange pointer



95-2312 2 1/16" Manifold pressure gauge 2-30 psi/13-207 kPa scale, black bezel



95-2369 2 1/16" Turbo pressure gauge 2-50 psi scale, chrome bezel



95-2366 2 1/16" Turbo pressure gauge 2-50 psi scale, black bezel, red-orange pointer

## 2 1/16" Fuel Pressure Gauges

Braided stainless steel tubing recommended.

BLACK BEZEL	CHROME BEZEL	SCALE
N/A	95-2350	10-200 psi
95-2345	95-2348	0-100 psi
N/A	95-2349	2-30 psi

## 2 1/16" Manifold Pressure Gauges

Requires pressure tubing kit for installation. For details see page 31 of this catalog.

BLACK BEZEL	CHROME BEZEL	SCALE	POINTER COLOR	REMARKS
95-2320	N/A	0-40 psi	white	backlit dial
95-2312	95-2313	2-30 psi/13-207 kPa	white	
95-2300	95-2306	2-30 psi	white	
95-2301	95-2307	2-30 psi	red-orange	
95-2302	N/A	1-15 psi	white	
95-2303	95-2309	1-15 psi	red-orange	

## 2 1/16" Turbo Pressure Gauges

Requires pressure tubing kit for installation. For details see page 31 of this catalog.

BLACK BEZEL	CHROME BEZEL	SCALE	POINTER COLOR	REMARKS
95-2376	N/A	0-60 psi	white	backlit dial
95-2384	N/A	0-60 psi	red-orange	backlit dial
95-2365	95-2369	2-50 psi	white	
95-2366	N/A	2-50 psi	red-orange	
95-2375	N/A	0-30 psi	white	backlit dial
95-2382	N/A	0-30 psi	red-orange	backlit dial

## 2 1/16" Vacuum Gauges

95-6264 tubing kit included with these units.

BLACK BEZEL	CHROME BEZEL	SCALE	POINTER COLOR
95-2407	N/A	2-30 inHg/50-760 mmHg	white
95-2400	95-2404	2-30 inHg	white
95-2401	N/A	2-30inHg	red-orange

## 2 1/16" Vacuum/Turbo Boost Gauges

Requires pressure tubing kit for installation. For details see page 31 of this catalog.

BLACK BEZEL	CHROME BEZEL	SCALE	POINTER COLOR	REMARKS
95-2432	N/A	0-30 inHg - 0-15psi	white	backlit dial
95-2425	95-2427	0-30 inHg - 0-15psi	white	



95-2404 2 1/16" Vacuum gauge 2-30 inHg scale, chrome bezel



95-2401 2 1/16" Vacuum gauge 2-30 inHg scale, black bezel, red-orange pointer



95-2427 2 1/16" Vacuum/turbo boost gauge 0-30 inHg - 0-15 psi scale, chrome bezel

## 2 1/16" Water Temperature Gauges

BLACK BEZEL	CHROME BEZEL	SCALE	CAPILLARY
95-2480	N/A	100-265°F/40-130°C	216"
95-2476	95-2485	100-265°F/40-130°C	144"
95-2478	95-2487	100-265°F/40-130°C	120"
95-2477	95-2486	100-265°F/40-130°C	96"
95-2475	95-2484	100-265°F/40-130°C	72"
95-2481	95-2490	100-265°F/40-130°C	60"
95-2479	95-2488	100-265°F/40-130°C	48"
N/A	95-2467	100-265°F	360"
N/A	95-2466	100-265°F	288"
N/A	95-2465	100-265°F	216"
95-2451	95-2461	100-265°F	144"
95-2453	95-2463	100-265°F	120"
95-2452	95-2462	100-265°F	96"
95-2450	95-2460	100-265°F	72"
95-2455	95-2468	100-265°F	60"
95-2454	95-2464	100-265°F	48"

## 2 1/16" Oil Temperature Gauges

BLACK BEZEL	CHROME BEZEL	SCALE	CAPILLARY
95-2541	95-2545	140-325°F/60-160°C	144"
95-2540	95-2544	140-325°F/60-160°C	72"
95-2531	95-2535	140-325°F	144"
95-2530	95-2534	140-325°F	72"

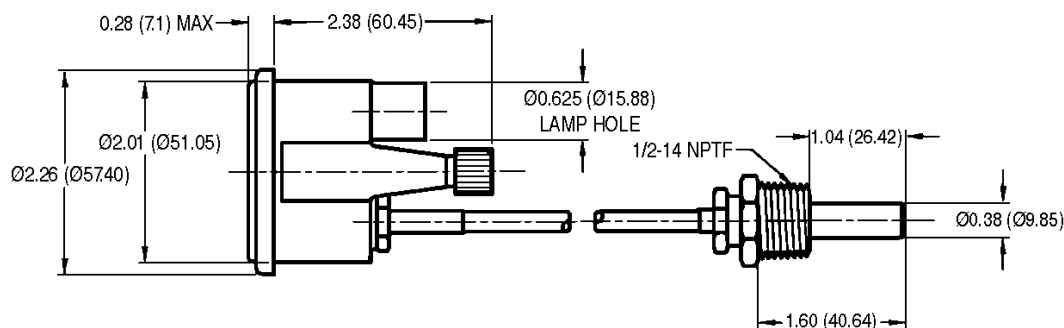

Typical view of a 2 1/16" mechanical temperature gauge

## Gauge Panels

Our most popular 2 1/16" gauges are available in pre-assembled three gauge panels. These include a color-coded voltmeter, mechanical water temperature gauge and mechanical oil pressure gauge with a six foot tubing kit and a mounting bracket. Specs:

- Oil pressure - 5-100 psi, 270° sweep. • Voltmeter - 12 VDC, 90° sweep, 10-16 VDC scale.
- Water temperature - 100-265°F, 270° sweep, 72" capillary.

BLACK BEZEL	CHROME BEZEL	REMARKS
95-2875	95-2876	
95-2879	95-2878	English Metric



95-2450 2 1/16" Water temperature gauge 100-265°F scale, black bezel



95-2465 2 1/16" Water temperature gauge 100-265°F scale, chrome bezel



95-2476 2 1/16" Water temperature gauge english/metric scale, black bezel



95-2478 2 1/16" Water temperature gauge english/metric scale, black bezel



95-2530 2 1/16" Oil temperature gauge 140-325°F scale, black bezel



95-2876 Gauge panel chrome



95-2570 2 1/16" Oil pressure gauge 0-80 psi scale, black bezel



95-2575 2 1/16" Oil pressure gauge 0-100 psi scale, chrome bezel



95-2578 2 1/16" Oil pressure gauge english/metric scale, black bezel



95-2584 2 1/16" Oil pressure gauge english/metric scale, chrome bezel



95-2587 2 1/16" Oil pressure gauge english/metric scale, black bezel



95-2592 2 1/16" Oil pressure gauge english/metric scale, black bezel



95-2630 2 1/16" Fuel level gauge 240-330 ohm, black bezel

## 2 1/16" Electrical Gauges

Electrical gauges are designed with a silicone dampened air core movement. A coil of wire is wound around a bobbin with a center magnet. When an electrical current is applied to the coil, the gauge pointer moves to the resulting electrical field. All electrical gauges have the same case, mounting dimensions and a 90° sweep.

Ordering information:

- These gauges require a sender. Senders must match the gauge type code and range. Please refer to pages 7 through 10 for more information about senders. Ammeters and voltmeters do not require a sender.
- Wiring with electrical ring terminals that providing 12 VDC NG and a ground, is also required.
- For trucks with 24 volt or 36 volt (negative ground) systems a voltage reducer is needed for the gauges listed as 12 volts. Ammeters and voltmeters do not require voltage reducers. Voltage reducers and related accessories are listed in the Specialty Products & Accessories section of this catalog (see page 31).

## 2 1/16" Oil Pressure Gauges

For sender information, see pages 7 and 8.

BLACK BEZEL	CHROME BEZEL	SCALE	SENDER TYPE	REMARKS
95-2594*	N/A	0-350 psi/0-25 Bar	PH	12 VDC
95-2596*	N/A	0-350 psi/0-25 Bar	PH	24 VDC
95-2592*	N/A	0-150 psi/0-10 Bar	PG	12 VDC
95-2593*	N/A	0-150 psi/0-10 Bar	PG	24 VDC
95-2587	95-2589	0-150 psi/0-1030 kPa	PD	12 VDC
95-2579	95-2584	0-100 psi/0-700 kPa	PB	12 VDC
N/A	95-2580	0-100 psi/0-700 kPa	PB	24 VDC
95-2571	95-2575	0-100 psi	PB	12 VDC
95-2590*	N/A	0-80 psi/0-5 Bar	PF	12 VDC
95-2591*	N/A	0-80 psi/0-5 Bar	PF	24 VDC
95-2578	95-2583	0-80 psi/0-500 kPa	PA	12 VDC
95-2570	95-2574	0-80 psi	PA	12 VDC

\* These units are compatible with VDO senders.

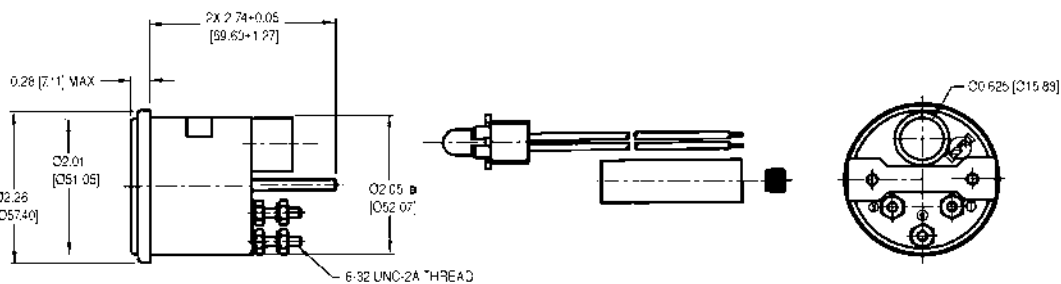

Typical view of a 2 1/16" electrical gauge

## 2 1/16" Fuel Level Gauges

For sender information, see pages 9 and 10.

BLACK BEZEL	CHROME BEZEL	SCALE	RESISTANCE	REMARKS
95-2634	95-2636	Empty, 1/4, 1/2, 3/4 & Full	240-33 ohm	12 VDC
95-2635	N/A	Empty, 1/4, 1/2, 3/4 & Full	240-33 ohm	24 VDC
95-2639*	N/A	Empty, 1/4, 1/2, 3/4 & Full	10-180 ohm	12 VDC
95-2640*	N/A	Empty, 1/4, 1/2, 3/4 & Full	10-180 ohm	24 VDC
95-2630	95-2631	Empty, 1/4, 1/2, 3/4 & Full	240-33 ohm	12 VDC

\* These units are compatible with VDO senders.



## 2 1/16" Ammeters

All ammeters shown below are internally shunted.

BLACK BEZEL	CHROME BEZEL	SCALE
95-2671	95-2674	100-0-100 amps
95-2670	95-2673	60-0-60 amps
95-2672	95-2675	30-0-30 amps
95-2662	95-2666	100-0-100 amps
95-2661	95-2665	60-0-60 amps
95-2660	95-2664	40-0-40 amps
95-2663	95-2667	30-0-30 amps



95-2660 2 1/16" Ammeter  
40-0-40 amp scale, black bezel



95-2665 2 1/16" Ammeter  
60-0-60 amp scale, chrome bezel



95-2662 2 1/16" Ammeter  
100-0-100 amp scale, black bezel



95-2667 2 1/16" Ammeter  
30-0-30 amp scale, chrome bezel

## 2 1/16" Voltmeters

All voltmeters have color-coded ranges and internal lighting except as noted.

BLACK BEZEL	CHROME BEZEL	SCALE
95-2698*	95-2702*	36 VDC/28-47 VDC
95-2697*	95-2701*	32 VDC/26-42 VDC
95-2705	95-2707	24 VDC/20-32 VDC
95-2696	95-2700	24 VDC/20-32 VDC
95-2704	95-2706	12 VDC/10-16 VDC
95-2695	95-2699	12 VDC/10-16 VDC

\* These units supplied without internal lighting.



95-2695 2 1/16" Voltmeter  
12VDC, black bezel

## 2 1/16" Air & Fuel Pressure Gauges

For sender information, see pages 7 and 8.

BLACK BEZEL	CHROME BEZEL	TYPE	Psi	SENDER TYPE
95-2847	95-2849	Air Pressure	0-150 psi/0-1030 kPa	PD
95-2845	95-2846	Air Pressure	0-150 psi	PD
95-2856	95-2857	Fuel Pressure	0-100 psi	—



95-2846 2 1/16" Air pressure gauge  
0-150 psi scale, chrome bezel



95-2847 2 1/16" Air pressure gauge  
english/metric scale, black bezel



95-2845 2 1/16" Air pressure gauge  
0-150 psi scale, black bezel



95-2700 2 1/16" Voltmeter 24 VDC, chrome bezel



95-2856 2 1/16" Fuel pressure gauge  
0-100 psi scale, black bezel



95-2857 2 1/16" Fuel pressure gauge  
0-100 psi scale, chrome bezel



95-2702 2 1/16" Voltmeter 36 VDC, chrome bezel



95-2697 2 1/16" Voltmeter  
32 VDC, black bezel



95-2740 2 1/16" Water temperature gauge 100-240°F scale, black bezel



95-2748 2 1/16" Oil temperature gauge 140-320°F scale, chrome bezel



95-2744 2 1/16" Temperature gauge 100-280°F scale, black bezel



95-2792 2 1/16" Transmission temperature gauge 100-280°F scale, black bezel



95-2758 2 1/16" Transmission temperature gauge english/metric scale, black bezel



95-3000 Pressure sender 1 stud



95-3009 Pressure sender 2 stud



95-3005 Pressure sender 2 stud with ground

## 2 1/16" Temperature Gauges

All units have red-orange pointers except where indicated. For sender information, see page 8.

BLACK BEZEL	CHROME BEZEL	SCALE	GAUGE TYPE	SENDER TYPE	REMARKS
95-2756	95-2760	140-320°F/60-160°C	Oil	TB	
95-2757	N/A	140-320°F/60-160°C	Oil	TB	24 VDC
95-2741	95-2748	140-320°F	Oil	TB	white-tip pointer
95-2742	N/A	140-320°F	Oil	TB	
95-2770*	N/A	120-300°F/50-150°C	Oil	TG	
95-2771*	N/A	120-300°F/50-150°C	Oil	TG	24 VDC
95-2764	95-2766	100-280°F/40-140°C	Temperature	TD	
95-2765	N/A	100-280°F/40-140°C	Temperature	TD	24 VDC
95-2744	95-2749	100-280°F	Temperature	TD	white-tip pointer
95-2758	95-2761	140-320°F/60-160°C	Transmission	TB	
95-2759	N/A	140-320°F/60-160°C	Transmission	TB	24 VDC
95-2743	N/A	140-320°F	Transmission	TB	
95-2788†	N/A	140-320°F	Trans/Oil	Included	white-tip pointer
95-2792†	N/A	100-280°F	Trans/Oil	Included	white-tip pointer
95-2768*	N/A	100-250°F/40-120°C	Water	TF	
95-2769*	N/A	100-250°F/40-120°C	Water	TF	24 VDC
95-2752	95-2754	100-240°F/40-115°C	Water	TA	
95-2753	N/A	100-240°F/40-115°C	Water	TA	24 VDC
95-2740	95-2747	100-240°F	Water	TA	white-tip pointer

\* These units are compatible with VDO senders. † These units come with a signal amplifier and matched send-

## Pressure Senders

Tectran pressure senders are designed to work best with Tectran electrical gauges but they are also compatible with many competing brands. Contact us for interchange information. Three kinds of pressure senders are available:

- The standard sender has one terminal and is designed to drive one gauge. The ground connection is made through the body of the sender.
- 95-3001, 95-3004 senders are for applications with two separate gauges. This sender type is commonly referred to as a "dual station". Gauges must be the same type code. One connection should be wired to each gauge. The body is the ground.
- 95-3002, 95-3005 senders are isolated ground senders. This type has a sender terminal to the gauge and a second terminal for a ground connection.
- Backlit gauges come complete with a signal amplifier and matched sender.

To order, select the kind of sender that fits your application, then match the type code and range of the sender with the type code and range of the gauge. 1/8" NPTF is standard.

PART NUMBER	TYPE CODE	RANGE	TERMINALS
95-3000	PA	0-80 psi	1 stud
95-3001	PA	0-80 psi	2 stud dual station
95-3002	PA	0-80 psi	2 stud with ground
95-3003	PB	0-100 psi	1 stud
95-3004	PB	0-100 psi	2 stud dual station
95-3005	PB	0-100 psi	2 stud with ground
95-3006	PD	0-150 psi	1 stud
95-3007*	PF	0-80 psi/5 bar	1 stud
95-3008*	PG	0-150 psi/10 bar	1stud
95-3009*	PH	0-350 psi/25 bar	2 stud

\* These units are compatible with VDO senders.

## Temperature Senders

Two termination types of temperature senders are available; standard 10-32 thread or isolated ground. For an explanation, see the pressure senders section on the previous page. We recommend that Tectran temperature senders be used with Tectran gauges to ensure accuracy.

Connections: Standard senders have one terminal for the gauge and grounding is through the body of the sender. 95-3021 and -3025 senders have one terminal for the gauge and one for the ground connection. For interchange information, contact us.

To order, determine the kind of sender needed and match type code and range with the gauge. Then, select the correct mounting thread for your application.

### 100-240°F RANGE, TA CODE

PART NUMBER	THREAD	TERMINALS
95-3020	1/2" NPTF	1 stud
95-3021	1/2" NPTF	2 blades
95-3022	3/8" NPTF	1 stud
95-3023	1/4" NPTF	1 stud
95-3024	1/8" NPTF	1 stud
95-3025	1/8" NPTF	2 blades
95-3026	M14 x 1.5	1 stud
95-3027	M16 x 1.5	1 stud
95-3028	M18 x 1.5	1 stud

### 140-320°F RANGE, TB CODE

PART NUMBER	THREAD	TERMINALS
95-3035	M14 x 1.5	1 stud
95-3036	M16 x 1.5	1 stud
95-3037	M18 x 1.5	1 stud
95-3038	1/8" NPTF	1 stud
95-3039	1/8" NPTF	2 blades
95-3040	1/4" NPTF	1 stud
95-3041	3/8" NPTF	1 stud
95-3042	1/2" NPTF	1 stud
95-3044	1/2"- 20 UNF	1 stud

PART NUMBER	CODE	TEMPERATURE	THREAD
95-3050	TF	250°F/120°C	1/2" NPTF
95-3051	TG	300°F/150°C	1/2" NPTF

PART NUMBER	CODE	RANGE	TERMINALS
95-3055	TC	140-320°F	1 stud
95-3056	TD	100-280°F	1 stud
95-3057	TA	100-240°F	1 stud
95-3058	TE	100-230°F	1 stud
95-3059	TB	140-320°F	1 stud

- 1/8" NPTF is standard
- Kits include 1/4", 3/8" and 1/2" adapter bushings

## Ultimate Pressure Senders

These senders are designed to provide increased reliability and accuracy. A ceramic resistor card is used instead of a wound wire resistor card. Movement across the resistor card is linear and pivot and hinge points have been eliminated. This provides extreme reliability for the toughest applications. Various combinations of connections, ranges and threads are possible. 1/8" NPTF thread is standard on all ultimate pressure senders. These senders are not for use in fuel pressure applications.

PART NUMBER	TYPE CODE	RANGE	TERMINALS	RESPONSE
95-3070	PA	0-80 psi	1 stud	240-33 ohm
95-3071	PB	0-100 psi	1 stud	240-33 ohm
95-3072	PD	0-150 psi	1 stud	240-33 ohm



95-3020 Temperature sender  
1 stud, 1/2" NPTF



95-3025 Temperature sender  
2 Blades



95-3050 Temperature sender  
VDO compatible, 1/2" NPTF



95-3051 Temperature sender  
VDO compatible, 1/2" NPTF



95-3056 Temperature sender  
kit, 1 stud, 100-280°F



95-3042 Temperature sender, 1  
stud, 1/2" NPTF



95-3038 Temperature sender  
1 stud, 1/8" NPTF



95-3044 Temperature sender  
1 stud, 140-320°F, 1/2" - 20UNF



95-3025 Temperature sender  
2 blades



95-3070 Ultimate pressure  
sender, 1 stud, 0-80 psi



95-3300  
6" tube, 240-33 ohm



95-3329  
36" tube, 240-33 ohm

## Ultimate Fuel Level Senders

Unlike the traditional float-arm style sender, our Ultimate fuel level sender consists of an internal PC board and floating reed switches all contained in a protective aluminum tube casing. This style is more durable and accurate, and is fast becoming the standard for new vehicles. The 95-33XX-series is available for most fuel tank sizes and in standard resistance curves.

- Standard SAE five bolt hole mounting.
- End cap keeps tube free of debris.
- Fluids measured: gas/diesel
- Temperature range: -90°C to 105°C
- Install within +/- 5(deg) from vertical for best results.
- Made in the USA

Resistance curves available:

STANDARD 240 - 33 ohm Items listed below

AC DELCO 0 - 90 ohm

FORD 78 - 10 ohm

EUROPEAN\* 10 - 180 ohm

Non-stock specialty items. Call for lead time and pricing.

\*VDO compatible.

### Technical Tip

Tube style senders are extremely durable and ideal for rugged applications. When ordering a tube style sender it is important to know the tank depth, resistance curve and tank shape.

Tank shape falls into two categories: volumetric (round and saddle) and non-volumetric (rectangular and square). Contact us for custom applications.

These senders are designed for use in gasoline and diesel fuel. Petroleum distillate additives or alcohol based additives at concentrations up to 10% of fuel mixture are permitted. These senders are not designed for use in applications involving water or other additives. The maximum operating temperature on these fuel level senders is 220°F.

PART NUMBER	TUBE LENGTH	TANK DEPTH	PART NUMBER	TUBE LENGTH	TANK DEPTH
95-3300	6"	6 1/2 - 7"	95-3315	21"	21 1/2 - 22"
95-3301	7"	7 1/2 - 8"	95-3316	22"	22 1/2 - 23"
95-3302	8"	8 1/2 - 9"	95-3317	23"	23 1/2 - 24"
95-3303	9"	9 1/2 - 10"	95-3318	24"	24 1/2 - 25"
95-3304	10"	10 1/2 - 11"	95-3319	25"	25 1/2 - 26"
95-3305	11"	11 1/2 - 12"	95-3320	26"	26 1/2 - 27"
95-3306	12"	12 1/2 - 13"	95-3321	27"	27 1/2 - 28"
95-3307	13"	13 1/2 - 14"	95-3322	28"	28 1/2 - 29"
95-3308	14"	14 1/2 - 15"	95-3323	29"	29 1/2 - 30"
95-3309	15"	15 1/2 - 16"	95-3324	30"	30 1/2 - 31"
95-3310	16"	16 1/2 - 17"	95-3325	31"	31 1/2 - 32"
95-3311	17"	17 1/2 - 18"	95-3326	32"	32 1/2 - 33"
95-3312	18"	18 1/2 - 19"	95-3327	33"	33 1/2 - 34"
95-3313	19"	19 1/2 - 20"	95-3328	34"	34 1/2 - 35"
95-3314	20"	20 1/2 - 21"	95-3329	36"	36 1/2 - 37"

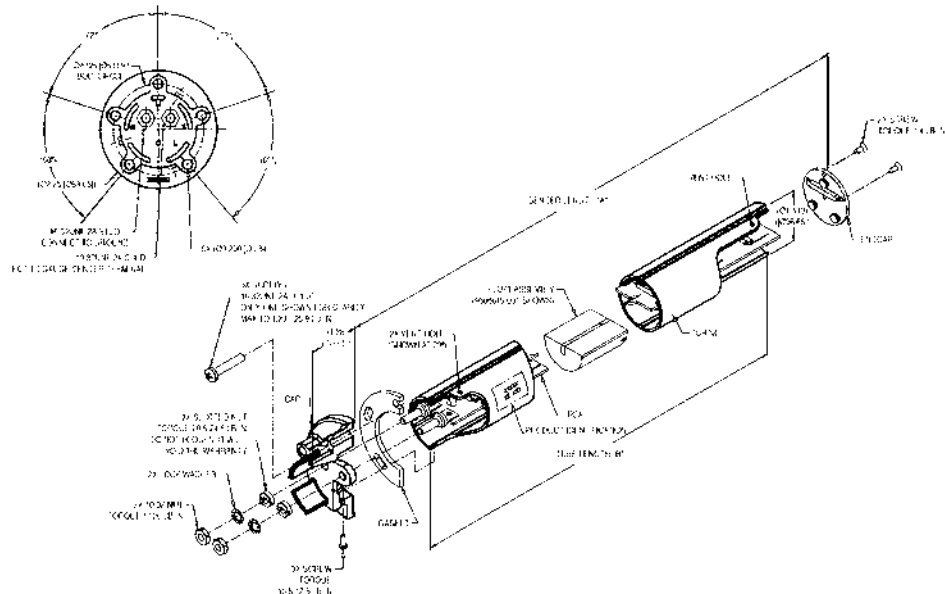

Ultimate fuel level sender drawing

### Ultimate Fuel Level Senders

This series is specifically calibrated for the cylindrically shaped tanks most commonly used on Class 8 trucks. These senders are ordered by the diameter of the fuel tank. To order, determine the diameter of the tank and order the appropriate part number.

PART NUMBER	FUEL TANK SIZE	PART NUMBER	FUEL TANK SIZE
95-3100	Tank O.D. 20"	95-3105	Tank O.D. 26"
95-3101	Tank O.D. 22"	95-3106	Tank O.D. 27"
95-3102	Tank O.D. 23"	95-3107	Tank O.D. 28"
95-3103	Tank O.D. 24"	95-3108	Tank O.D. 29"
95-3104	Tank O.D. 25"		

### Float Arm Fuel Level Senders

Most senders are adjustable for tanks with 6 -27 inch depth. They fit right or left hand swing applications. Contact us for interchange information.

PART NUMBER	RANGE	USE
95-3120*	240-33 ohm	with Tectran or Isspro gauges
95-3121	0-90 ohm	with AC type gauges
95-3122	78-10 ohm	with Ford or Chrysler
95-3123		replacement float for 93-3120, 21, 22
95-3124**	10-180 ohm	matches response of VDO models

\* Can be used with most other brands of gauges. \*\* Adjustable for 6-23 inch tank depth.



95-3100 Fuel Sender  
20" O.D. fuel tank size



95-3108 Fuel Sender  
29" O.D. fuel tank size



95-3120 Float arm fuel level sender  
240-33 ohm, use with Tectran gauges



95-3124 Float arm fuel level sender  
10-180 ohm, use with VDO match response

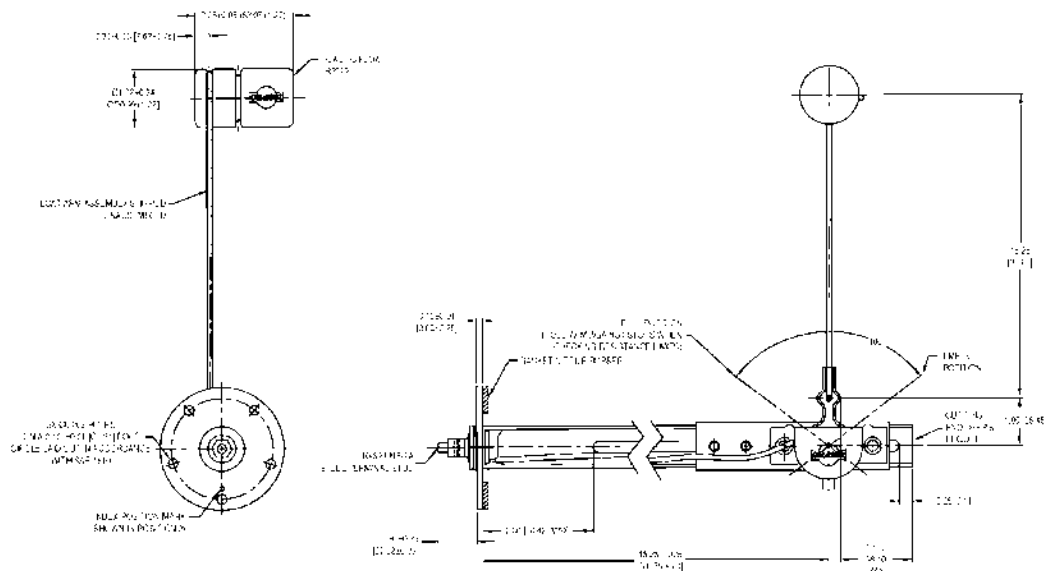

95-3120 float arm fuel level sender drawing

### Technical Tip

Traditional, float arm senders use a hollow float attached to a thin rod arm that extends into the tank. The movement of the arm over a resistor card sends resistance information to the gauge. This type of sender is prone to damage and less accurate than the Ultimate tube-style sender.



## Pyrometers



A pyrometer is an exhaust temperature gauge which reads exhaust temperature by a signal from a probe (thermocouple) inserted into the exhaust manifold. The monitoring of temperature alerts the driver to problems well before indications would be received from a water temperature gauge. Drivers can use pyrometers to diagnose engine problems and drive more efficiently, prolonging engine life and reducing fuel consumption.

Tectran has partnered with Isspro, Inc., premier manufacturer of pyrometers for the heavy duty, marine and industrial markets, to offer a wide variety of pyrometers.



### Contents

- Pyrometers Gauges - 2 1/16", 2 3/4", 3"
- Digital Pyrometers
- Dual Pyrometers
- Turbocators
- Thermocouples
- Lead Wires
- Thermocouple Accessories
- Pyrometer Tester
- Application Guidelines

## Pyrometers

The diesel engine takes energy from heat and converts it into motion to transport goods. **Excessive temperature is the greatest cause of damage to an engine.** By monitoring the temperature of the exhaust, you can detect changes in temperature which may be the early signs of trouble. A pyrometer, which measures and reports exhaust temperature, will indicate engine problems more efficiently than any other method.

**The pyrometer is one of the first indicators of trouble.** If an injector clogs, a cylinder or piston cracks, or an electronic injector has a problem, a pyrometer will note a change in temperature. The reason a pyrometer will call attention to engine problems faster is that a pyrometer measures the internal thermo-dynamics of an engine. The benefits are longer engine life, better fuel consumption, lower emissions and an indication of malfunctions before damage occurs.

### We offer the most widely used pyrometer system:

- Type K (chromel-alumel material), is designed for high temperature applications (to 2000°F), covering most diesel and gas engine applications.

### To design your own pyrometer system:

- Choose the proper pyrometer, by determining the temperature range you wish to measure and the size of the mounting hole for the gauge.
- Select the required thermocouple probe length and most convenient mounting style.
- Choose the appropriate length of lead wire and termination style to connect to the gauge and thermocouple.
- For highest accuracy and long life, do not mix components from different manufacturers within a pyrometer system.

### Standard features of our pyrometers:

- All our pyrometers have red-orange pointers.
- 12 VDC light kit is included. For a 24 VDC lamp, see page 30 in the Specialty & Accessories section of this catalog.
- Made in the USA.

## 2 1/16" Pyrometers

PART NUMBER	ISSPRO No.	°F SCALE	°C SCALE	SWEEP	BEZEL	REMARKS
95-5013	R607G	0-1500°	None	250°	Black	
95-5016*	R607T	0-1500°	None	250°	Black	color-coded dial
95-5019**	R607WV	0-1500°	None	250°	Black	color-coded dial
95-5242* †	R3607T	100-1500°	None	250°	Black	color-coded backlit dial
95-5243** †	R3607VW	100-1500°	None	250°	Black	color-coded backlit dial
95-5000	R605	300-1500°	200-800°	100°	Black	
95-5006	R605P	300-1500°	200-800°	100°	Chrome	
95-5007	R607	0-1800°	0-1000°	250°	Black	
95-5014	R607P	0-1800°	0-1000°	250°	Chrome	

\*Warning begins at 1100° for pre turbo installations \*\*Warning begins at 900° for post turbo installations

† These units come with a signal amplifier

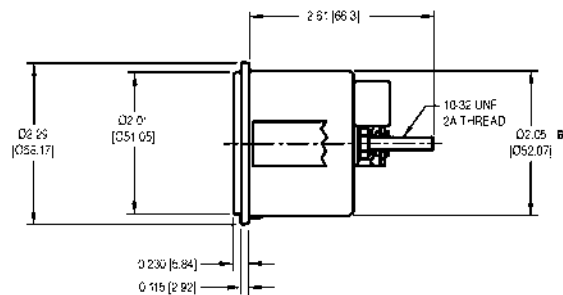

Typical view of a 2 1/16" pyrometer

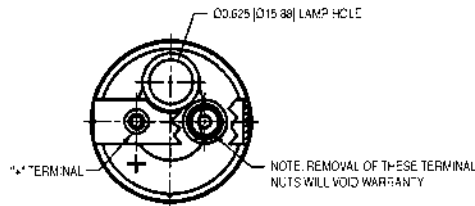

95-5019 2 1/16" Pyrometer  
250° sweep, black bezel,  
colored dial



95-5243 Pyrometer, 250°  
sweep, black bezel



95-5000 2 1/16" Pyrometer 100°  
sweep, black bezel



95-5006 2 1/16" Pyrometer  
100° sweep, chrome bezel



95-5007 2 1/16" Pyrometer  
250° sweep, black bezel



95-5014 2 1/16" Pyrometer  
250° sweep, chrome bezel



95-5085 2 1/16" Digital Pyrometer, black bezel



95-5040 3" Pyrometer 100° sweep, black bezel



95-5049 3" Pyrometer 250° sweep, black bezel



95-5054 3" Pyrometer 250° sweep, chrome bezel



95-5079 3" Dual pyrometer chrome bezel



95-5100 3" Turbocator and kit black bezel shown



## 2 1/16" Digital Pyrometers

All units have 0.3" LED displays. Celsius scales are also available.

PART NUMBER	ISSPRO No.	°F SCALE	PROBE	BEZEL
95-5085	R630	0-1990°	type K	Black
95-5088	R630-24VDC	0-1990°	type K	Black
95-5090	R630P	0-1990°	type K	Chrome

## 2 3/4" Pyrometer

PART NUMBER	ISSPRO No.	°F SCALE	°C SCALE	SWEEP	BEZEL	REMARKS
95-5030	R602	0-1800°	0-1000°	100°	Black	

## 3" Pyrometers

Requires pressure tubing kit for installation. For details, see page 31 of this catalog.

PART NUMBER	ISSPRO No.	°F SCALE	°C SCALE	SWEEP	BEZEL	REMARKS
95-5040	R604	0-1800°	0-1000°	100°	Black	
95-5048	R604P	0-1800°	0-1000°	100°	Chrome	
95-5049	R606	0-1800°	0-1000°	250°	Black	
95-5054	R606P	0-1800°	0-1000°	250°	Chrome	

## 3" Specialty Pyrometers

PART NUMBER	ISSPRO No.	°F SCALE	°C SCALE	BEZEL	REMARKS
95-5076	R624	300-1500°	200-800°	Black	Features dual pyrometer, two meters. Requires two thermocouples
95-5079	R624P	300-1500°	200-800°	Chrome	Features dual pyrometer, two meters. Requires two thermocouples

## 3" Turbocator

Dual scales allow monitoring of exhaust temperature on the lower scale and turbo boost pressure on the upper scale. Turbocator kits (95-5101, 95-5102) include tubing, lead wire and thermocouple. Black bezel. 100° sweep. Chrome bezel available.

PART NUMBER	ISSPRO No.	°F SCALE	°C SCALE	BOOST RANGE	BEZEL
95-5100	R609	300-1500°	None	0-30 psi	Black



The horsepower developed by a diesel engine depends on the amount of fuel burned. For maximum efficiency it is important that the fuel and air delivered to the combustion chambers is supplied in the proper ratio. It takes about 2,500 gallons of air for every gallon of fuel to provide efficient combustion. High exhaust temperature, excessive or incomplete fueling all will affect the efficiency of the engine.

Increases in exhaust temperatures are caused by:

- 1) Excessive fueling: Caused either by improper use of the throttle or by a faulty fuel system. Fueling problems on electronically controlled engines will first show up on the pyrometer, since the exhaust temperature will increase approximately by five degrees for every pound of excess fuel burned.
- 2) High intake air temperature: Every degree increase of intake air temperature will cause a three-degree rise in the exhaust temperature.
- 3) Air restriction: Caused by dirty air cleaners (intake restriction). For every increase of ten inches of engine vacuum, there will be a corresponding increase of thirty degrees in the exhaust temperature.
- 4) Vehicle operation at higher altitude: For every 1000 foot increase in operating altitude there will be a twenty five degree rise in the exhaust temperature.
- 5) Increase in rolling resistance due to improper tire inflation or operating into a headwind.
- 6) Lugging the engine due to improper throttle use or improper shifting.

Excessive heat is one of the enemies of turbochargers. The maximum input temperature to a turbocharger should be in the 1400 degree F range. Temperatures higher than this will hasten the deterioration of the turbocharger's housing through cracking, and will foul the turbocharger and may also result in damage to the intake and exhaust manifolds and cylinders.

Engine over revving through excessive fueling can give cause to many engine problems such as breaking valves, and heat damage to both the engine and the turbocharger. Over speeding of the engine past the governed speed on down grades will cause the engine governor to shut off fuel to the injectors, thereby depriving them of lubrication which can result in sticking injectors. Badly adjusted speed governors, incorrect governor settings, or wrong governor selection can all lead to engine damage.

Incomplete fueling is another cause of many engine problems. Often caused by restricted air supply, it too will lead to excessive fuel consumption. The unburned fuel will wash lubricating oil off the cylinder walls, causing burned or scored pistons and damaged piston rings. Unburned fuel may also contaminate and dilute the lubricating oil.



To determine the **safe maximum exhaust temperature**, run a well tuned engine at full RPM and horsepower on an inertia dynamometer or under full load. Note the exhaust temperature and subtract 200 F degrees, which gives the safe maximum exhaust temperature. This temperature may be exceeded for short periods of time without causing serious damage, but staying in the upper third of the temperature range of the pyrometer will give the best performance and will reduce the danger of engine problems.



95-5169 Leadwire Plug in connector



95-5173 Lead wire standard length



95-5121 Thermocouple hose clamp for easy installation



95-5127 Thermocouple for smaller diameter exhaust tubes



95-5130 Thermocouple plug-in connector



95-5131 Thermocouple probe, adjustable for depth



95-5138 Thermocouple plug-in connector

## Lead Wires

A type K high temperature lead wire is required for all of the pyrometers contained in this catalog. They are generally purchased separately but can also be purchased along with the gauge, thermocouple and weld bushing, as part of a convenient pyrometer system kit. Refer to the price list for kits

WITH RING TERMINAL			WITH PLUG-IN		
PART NUMBER	ISSPRO No.	LENGTH	PART NUMBER	ISSPRO No.	LENGTH
95-5165	R660-6	6 ft.	95-5169	R660-6PL	6 ft.
95-5173	R660-10	10 ft.	95-5174	R660-10PL	10 ft.
95-5175	R660-14	14 ft.	95-5176	R660-14PL	14 ft.

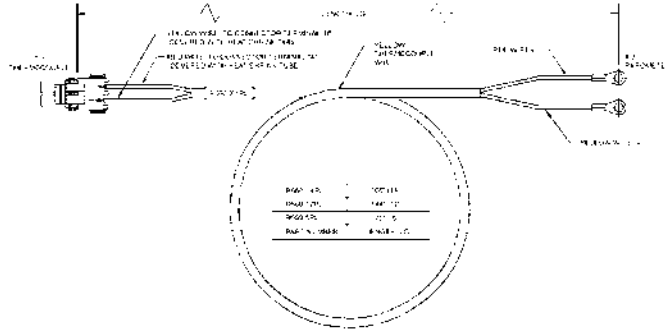

## Thermocouples

The **thermocouple** is the primary element of the pyrometer system. Two different types of metal are induction welded together to form the tip of the thermocouple. This assures a fast reaction time because the tip and thermocouple wire are the same and this junction is protected from damage. The tip is made of stainless steel and is filled with a ceramic material, making the probe solid and protecting the internal wires from damage.

The aircraft quality Kapton® leads are encased in a flexible stainless steel wire braid for protection from heat and abrasion. A spiral wound strain relief spring protects the wire at the exit point of the probe. When heat is applied to the thermocouple a voltage proportional to the amount of heat applied is produced, and this voltage is read by the pyrometer and interpreted as a temperature. Note that it is important to never introduce any solder joints between the thermocouple and the pyrometer as such joints would introduce further voltages which would affect the calibration of the pyrometer and produce erroneous readings. The pyrometers cataloged here are calibrated to a type K thermocouple which produce  $-1.63nV$  at  $0^{\circ}F$  and  $26.03mV$  at  $1200^{\circ}F$  (Ref. Junc.  $75^{\circ}F$ )

PART NUMBER	ISSPRO No.	MOUNTING	°F SCALE	PROBE LENGTH	EXHAUST TUBE DIAMETER	GAUGE CONNECTION
95-5120	R650	1/4" NPTF	0-1600°	2.25"	Standard	Bolt-on
95-5126	R650PL	1/4" NPTF	0-1600°	2.25"	Standard	Plug-in
95-5127	R650S	1/4" NPTF	0-1600°	1.6"	Small	Bolt-on
95-5130	R650SPL	1/4" NPTF	0-1600°	1.6"	Small	Plug-in
95-5131	R658	1/4" NPTF	0-1600°	Adjustable	Standard	Bolt-on
95-5134	R658PL	1/4" NPTF	0-1600°	Adjustable	Standard	Plug-in
95-5135	R658S	1/4" NPTF	0-1600°	Adjustable	Small	Bolt-on
95-5138	R658SPL	1/4" NPTF	0-1600°	Adjustable	Small	Plug-in
95-5124	R650HT	1/4" NPTF	0-2000°	2.25"	Standard	Bolt-on
95-5125	R650HT-PL	1/4" clamp	0-2000°	2.25"	Standard	Plug-in
95-5128	R650SHT	1/4" NPTF	0-2000°	1.6"	Small	Bolt-on
95-5129	R650SHT-PL	1/4" NPTF	0-2000°	1.6"	Small	Plug-in
95-5132	R658-HT	1/4" NPTF	0-2000°	Adjustable	Standard	Bolt-on
95-5133	R658HT-PL	1/4" NPTF	0-2000°	Adjustable	Standard	Plug-in
95-5136	R658SHT	1/4" NPTF	0-2000°	Adjustable	Small	Bolt-on
95-5137	R658SHT-PL	1/4" NPTF	0-2000°	Adjustable	Small	Plug-in
95-5121	R650A-HT	clamp	0-2000°	Adjustable	Standard	Bolt-on
95-5123	R650A-HT-PL	clamp	0-2000°	Adjustable	Standard	Plug-in

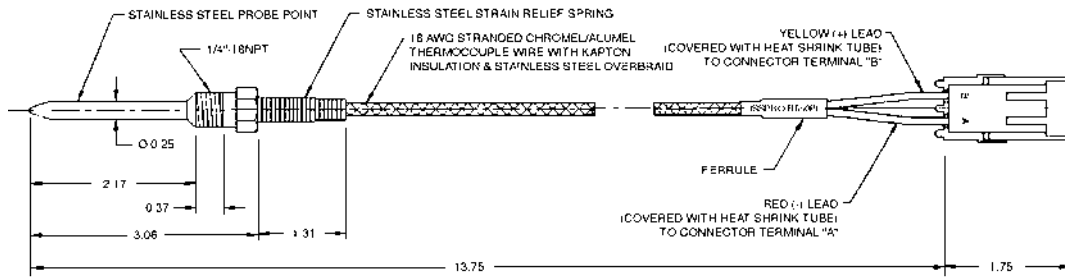

95-5126 Thermocouple

### Thermocouple Accessories

PART NUMBER	ISSPRO No.	TYPE	DESCRIPTION
95-5155	R680	Weld Bushing	Weld onto exhaust tube for a 1/4" NPTF connection to mount thermocouple.
95-5156	R681	Compression Fitting	Brass, 1/8-27 NPTF
95-5157	R682	Compression Fitting	Brass, 1/4-18 NPTF
95-5158	R683	Compression Fitting	Steel, 1/8-27 NPTF
95-5160	R7980	Fiberglass sleeve	Protects thermocouple leads from shorting.



95-5155 Weld bushing



95-5156 Compression fitting brass, 1/8-27 NPTF

### Pyrometer Tester

#### 95-5221 Pyrometer Tester

We have found that over 75% of all warranty claims are for non-defective parts. Mechanics have not had an inexpensive way of testing the pyrometer system. Our **Pyrometer System Tester** (illustrated below) eliminates guess work by checking the thermocouple and lead wire continuity. It allows running the meter through the entire scale to check its operation, thus diagnosing the complete system in a few minutes.



## Technical Tips

Hot engine shutdown is a major cause of turbocharger damage. To prevent this, engine manufacturers recommend idling an engine for a period of time before it is shut down. This allows oil to flow through the bearings to cool them. The goal is to reduce bearing temperature to 300°F. Using Tectran's Turbo Temp Monitor can achieve this (see page 30 in the Specialty & Accessories section). A thermocouple is mounted downstream of the turbocharger and monitors exhaust gas temperature and delays shutdown until 300°F is reached. Shutting the engine down after proper cooling prevents dangerous deposits from forming and turbo life is increased.



*Refer to the Specialty Products and Accessories section of this catalog for more information about Turbo Temp Monitors and Engine Shutdown/Protection Kits.*



All too often, a mechanic will install a replacement gauge only to find that the fault condition still exists with the new gauge. When trouble-shooting pyrometer systems, be sure to test the lead wire, its connections and the thermocouple as well as the gauge. Tectran can supply complete kits that include all of the components needed in the pyrometer system. This kit approach is also convenient for retrofitting vehicles that do not have exhaust temperature measurement systems.

## Design Your Own Pyrometer System...

Pyrometers	Step 1	Thermocouples	Step 2	Lead Wires	Step 3
List Your Part Number Selections Here	1. _____	List Your Part Number Selections Here	1. _____	List Your Part Number Selections Here	1. _____
	2. _____		2. _____		2. _____
	3. _____		3. _____		3. _____
	4. _____		4. _____		4. _____
	5. _____		5. _____		5. _____
Select Your Pyrometer (see pages 12 -13)		Select Your Thermocouple (see page 15)		Select Your Leadwire (see page 15)	

**Congratulations! Your Pyrometer System Is Complete.**

- Tectran speedometers are robust and reliable in heavy duty equipment environments. Electronic models such as the micro-processor units with two-speed axle switching utilize the latest in design technology
- High quality mechanical and programmable speedometers, sensors and generators are also offered.
- Our line of speedometers fit the broadest application range with a minimum of part numbers.



## Speedometers & Tachometers



### Contents

- Mechanical Speedometers
- Programmable Speedometers
- Magnetic Sensors & Signal Generators
- Mechanical Tachometers
- Speedometer & Tachometer Cable Parts
- Interconnect Harnesses
- Programmable Tachometers
- Electronic Tachometers
- Alternator Tachometers
- Ignition Tachometers
- Hand Held Tachometer
- Specialty Devices
- Product Specifications





95-0400 Speedometer 4 5/8", english/metric scale, black bezel



95-0402 Speedometer 5", 80 mph scale, black bezel



95-0404 Speedometer 3 3/8", 120 mph scale, chrome bezel



95-0408 Speedometer 3 3/8", 120 mph scale, chrome bezel, with trip odometer



95-0410 Speedometer 3 3/8", english/metric, black bezel



95-0413 Speedometer 3 3/8", 80 mph scale, black bezel

## Mechanical Speedometers

These gauges are driven mechanically by a speedometer cable. They are calibrated for use in applications generating 1,000 cable revolutions per mile (except metric units) with a standard 0.104" square tip and 5/8"-18 cable nut. Features:

- All models have million mile odometers with tenths and several have trip odometers.
- The chrome bezel is a true bright chrome which matches older equipment.
- Mounting hardware and light kit is included.
- Optional features (bezels, pointer color, face dials/ranges) are available. Contact the factory.
- Made in the USA.

PART NUMBER	SIZE	SCALE	ODOMETER	BEZEL	POINTER
95-0402	5"	80 mph	yes	Black	white tip
95-0400	4 5/8"	80mph/130 kph	yes	Black	red-orange tip
95-0409	3 3/8"	120 mph	yes + trip	Black	white tip
95-0408	3 3/8"	120 mph	yes + trip	Chrome	white tip
95-0405	3 3/8"	120 mph	yes	Black	white tip
95-0404	3 3/8"	120 mph	yes	Chrome	white tip
95-0406	3 3/8"	80 mph	yes + trip	Black	white tip
95-0407	3 3/8"	80 mph	yes + trip	Chrome	white tip
95-0423	3 3/8"	80mph/130 kph	yes, metric	Black	white tip
95-0424	3 3/8"	80mph/130 kph	yes, metric	Chrome	white tip
95-0410	3 3/8"	80mph/130 kph	yes	Black	red-orange tip
95-0413	3 3/8"	80 mph	yes	Black	white tip
95-0412	3 3/8"	80 mph	yes	Chrome	white tip

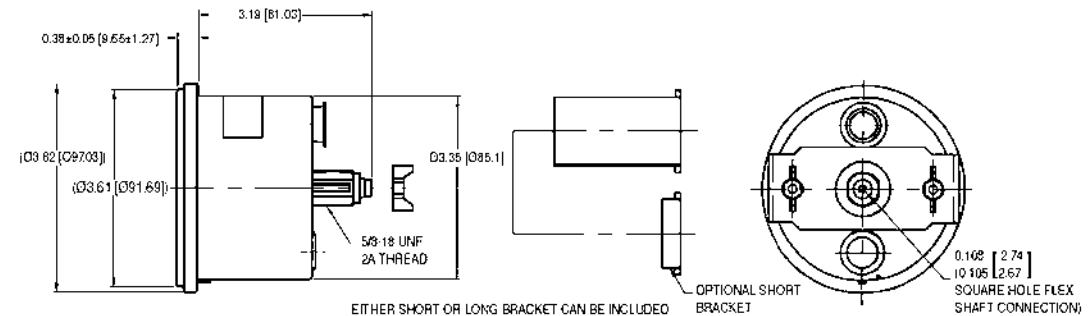

Typical view of a 3 3/8" mechanical speedometer.

## Programmable Speedometers

These speedometers are driven electronically by a signal generated by a pulse generator or magnetic pickup. They function over a broad range of applications by using dip switches for field programmability. For replacement applications, they will accept signals from most sensors or generators in use. For 24 VDC NG applications, a 24 VDC bulb must be purchased separately. See Gauge Lighting section on page 33. Features:

- All odometers are six digit, (million mile) with tenths of a mile.
- Speedometers are available in 3 3/8", 4 5/8" and 5" mounting diameters.
- 3 3/8" units are 12 or 24 VDC NG.
- 4 5/8" and 5" units are 12 VDC NG standard. 24 VDC NG is optional. Specify when ordering.
- Mounting hardware and lighting kit are included.
- Silicon dampened air core movement provides steady readings.
- Non-microprocessor units are available for special applications.
- Optional styling features are also available.
- Resettable odometer can be set to match the mileage on the unit which is being replaced.
- Two speed axle reading switching is automatic on 4 5/8" models and microprocessor units.
- English scale predominant on all dual scale units.
- Contact us for positive ground applications.
- Made in the USA.



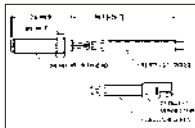

95-0017 Sensor

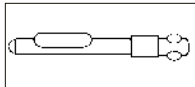

Male drive tip

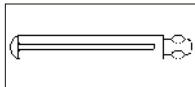

Female drive tip



95-0010 Sensor 2.6", with wire leads



95-0031 Sender 7/8"-18, generator



95-0700 Tachometer 5", 0-3000 rpm, black bezel



95-0704 Tachometer 4 5/8", 0-3500 rpm, black bezel



95-0706 Tachometer 3 3/8", 0-3500 rpm, chrome bezel



95-0707 Tachometer 3 3/8", 0-3500 rpm, chrome bezel

## Magnetic Sensors & Signal Generators

MAGNETIC SENSORS			SIGNAL GENERATORS (30 PULSES/REV)
All mounting threads are 3/4" - 16, except 95-0013, which is 5/8"-18.			
PART NUMBER	HOUSING LENGTH	CONNECTIONS	95-0030
95-0010	2.6"	wire leads	Sender, 7/8"-18, feed through. One male and one female drive tip required.
95-0011	4.4"	wire leads	
95-0012	3.1"	wire leads	95-0031
95-0013	4.0"	wire leads	
95-0014	3.0"	terminals	
95-0015	4.8"	terminals	
95-0016	3.5"	terminals	Sender, 7/8"-18, generator. One male drive tip required.
95-0017	2.6"	plug w/mating conn	

### DRIVE TIP GENERATORS

MALE		FEMALE	
95-0040	.152" tang	95-0048	.203" tang hole
95-0041	.187" tang	95-0049	.104" square hole
95-0042	.203" tang	95-0050	.152" tang hole
95-0043	.104" square	95-0051	.187" tang hole
95-0044	.150" square		

## Tachometers

As with our speedometers, Tectran's tachometer line is designed to withstand adverse environments and is the most comprehensive of any aftermarket supplier. Mechanical, programmable, ignition and alternator tachometers are available. Optional styling features such as bezels, ranges, custom dials and pointer colors are available by contacting the factory. Non-microprocessor units are available for special applications.

### Mechanical Tachometers

These tachometers are cable driven and offer the same features as our mechanical speedometers. They are rugged and reliable for new or replacement applications.

PART NUMBER	SIZE	SCALE	COUNTER	BEZEL	POINTER	RATIO
95-0700	5"	0-3000 rpm	no	Black	white tip	.5:1
95-0701	5"	0-3000 rpm	yes	Black	white tip	.5:1
95-0704	4 5/8"	0-3500 rpm	no	Black	red-orange tip	.5:1
95-0710	3 3/8"	0-3500 rpm	yes	Black	white tip	.5:1
95-0707	3 3/8"	0-3500 rpm	yes	Chrome	white tip	.5:1
95-0705	3 3/8"	0-3500 rpm	no	Black	white tip	.5:1
95-0706	3 3/8"	0-3500 rpm	no	Chrome	white tip	.5:1
95-0712	3 3/8"	0-3500 rpm	yes	Black	white tip	1:1
95-0709	3 3/8"	0-3500 rpm	yes	Chrome	white tip	1:1
95-0711	3 3/8"	0-3500 rpm	no	Black	white tip	1:1
95-0708	3 3/8"	0-3500 rpm	no	Chrome	white tip	1:1
95-0713	3 3/8"	0-2500 rpm	yes	Chrome	all white	1:1
95-0715	3 3/8"	0-2500 rpm	yes	Chrome	all white	1:1 ccw
95-0717	3 3/8"	0-2500 rpm	yes	Chrome	all white	.5:1



## Speedometer & Tachometer Cable Parts

Tectran offers a complete selection of tips, ferrules, core and casing for mechanical speedometer and tachometer drives. Commonly ordered items are listed below.

PART NUMBER		PART NUMBER	
95-0060	Comp. ferrule for .445 hsg	95-0083	Extension tip for .150 core, .203 tang hole
95-0061	Upper ferrule for .445 hsg, 5/8 nut	95-0084	Extension tip for .150 core, .104" sq
95-0062	Lower ferrule for .445 hsg	95-0085	Extension ferrule for .445 hsg
95-0063	Nut, 7/8/18	95-0088	Lower tip for .130 core, .124" sq
95-0064	Lower tip for .150 core, .150" sq	95-0089	Upper tip for .130 core, .104" sq hole
95-0065	Short tip for .150 core, .104" sq	95-0090	Brass collar
95-0067	Lower tip for .150 core, .203" tang	95-0093	Lower ferrule for .297 housing
95-0068	Lower tip for .150 core, .187" tang	95-0096	Upper ferrule for .330 housing, GM
95-0069	Lower tip for .150 core, .152" tang	95-0098	Upper ferrule for .330 housing
95-0070	Lower tip for .150 core, .104" sq	95-0100	Lower ferrule for .330 housing
95-0071	Upper tip for .150 core, .104" sq	95-0102	Casing, .445 metal-vinyl, 100'
95-0072	Comp. tip for .150 core, .152" tang	95-0103	Core, .130, 100'
95-0073	Comp. tip for .150 core, .187" tang	95-0104	Core, .130, 500'
95-0074	Comp. tip for .150 core, .203" tang	95-0105	Core, .130, 1000'
95-0075	Comp. tip for .150 core, .104" sq	95-0106	Core, .150, 100'
95-0076	Comp. tip for .150 core, .150" sq	95-0107	Core, .150, 500'
95-0077	Upper tip for .150 core, .187" sq hole	95-0108	Core, .150, 1000'
95-0078	Lower tip for .150 core, .203" tang	95-0110	Core, .187, 100'
95-0081	Lower tip for .150 core, .124" sq	95-0112	Casing, .330, metal-vinyl, 100'

## Interconnect Harnesses

For installation of Tectran speedometers and tachometers in original electronic equipment applications.

PART NUMBER	APPLICATIONS
95-0140	Adapts Peterbilt 17-03551-001 for Tectran unit 95-0519
	Adapts Peterbilt 17-03551-002 for Tectran unit 95-0519
	Adapts Peterbilt 17-03552-001 for Tectran unit 95-0904
	Adapts Peterbilt 17-03552-002 for Tectran unit 95-0906
	Adapts Kenworth 3K tachometers (with or without hourmeter) for Tectran unit 95-0904
95-0141	Adapts Peterbilt part numbers: 14-03190 for Tectran 95-0519, 17-03183 for Tectran 95-0904
95-0142	Adapts Kenworth K152-471 for Tectran unit 95-0504

## Technical Tip

### Checking the accuracy of the speedometer after installation:

After the speedometer has been installed in the vehicle, the accuracy of the indication may be checked and corrected as follows.

The vehicle should be driven at a constant speed. The time taken and the distance traveled should be noted. The distance traveled is to be taken from the milepost and not from the odometer indication. A stopwatch is suggested to measure the time.

The speed indicated by the speedometer also to be noted. (Indicated speed)

The exercise may be repeated three or four times. From this data the actual speed of the vehicle and programming number can be determined with the following equations.

$$\text{Actual speed (MPH)} = \frac{\text{Sum of the distance traveled for three passes in miles}}{\text{Sum of the time taken for three passes in seconds}} \times 3600$$

$$\text{New programming number} = \frac{\text{Set programming} \times \text{indicated speed}}{\text{Actual speed}}$$

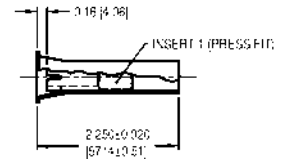

95-0060 Comp. ferrule for .445 hsg

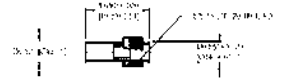

95-0061 Upper ferrule for .445 hsg, 5/8-18 nut



95-0107 Core .150, 500'



95-0112 Casing .330, metal-vinyl, 100'



95-0141 Interconnect harness

Speedometers & Tachometers

## Technical Tip

### Finding the programming number:

The programming number = the number of output pulses from the sensor per mile.

If the programming number is indicated in the vehicle's user manual, go to "Setting the programming number". If the number is not available, connect a pulse measuring counter to the sensor and find the number of pulses output by driving the vehicle one mile. The milepost on the road can be used as a reference. It is suggested to repeat the exercise a few times and average value.

The speedometer will work with the signals from either a magnetic pick-up sensor or Hall effect sensor.



95-0903 Tachometer  
3 3/8", 0-2000 rpm, black bezel



95-0907 Tachometer  
3 3/8", 0-3000 rpm, chrome bezel



95-0915 Tachometer  
5", 0-3000 rpm, black bezel



95-0916 Tachometer  
4 5/8", 0-3500 rpm, black bezel



95-0920 Tachometer  
3 3/8", 0-4000 rpm, black bezel



95-0924 Tachometer  
3 3/8", 0-4000 rpm, black bezel



95-0932 Tachometer  
3 3/8", 0-5000 rpm, black bezel

## Programmable Tachometers

These instruments are designed to accept signals from pulse generators, magnetic senders or alternator taps. Alternator signals vary significantly and applications must be checked for proper function. For 24 VDC NG applications, a 24 VDC bulb must be purchased separately. See page 30 in Specialty Products & Accessories section of this catalog. Features:

- Most units have hourmeters that count only when a signal is present (engine running).
- 12 or 24 VDC NG operation on 3 3/8" models.
- 4 5/8" and 5" units are 12 VDC NG standard. 24 VDC NG is optional. Specify when ordering.
- Dip switch programming.
- Mounting hardware and light kit are included.
- Silicone dampened air core movements and black bezels are standard.
- Non-microprocessor units are available for special applications.
- Contact us for positive ground applications.
- Made in the USA.

PART NUMBER	SIZE	MICROPROCESSOR	SCALE	HOURLMETER	BEZEL	POINTER
95-0914	5"	no	0-3000 rpm	no	Black	white tip
95-0915	5"	no	0-3000 rpm	no	Black	red-orange tip
95-0916	4 5/8"	no	0-3500 rpm	no	Black	red-orange tip
95-0934	3 3/8"	yes	0-8000 rpm	no	Black	white tip
95-0920	3 3/8"	yes	0-6000 rpm	no	Black	white tip
95-0917	3 3/8"	no	0-6000 rpm	no	Black	white tip
95-0931	3 3/8"	yes	0-5000 rpm	yes	Black	white tip
95-0932	3 3/8"	yes	0-5000 rpm	no	Black	white tip
95-0930	3 3/8"	no	0-5000 rpm	yes	Black	white tip
95-0929	3 3/8"	no	0-5000 rpm	no	Black	white tip
95-0924	3 3/8"	yes	0-4000 rpm	yes	Black	white tip
95-0927	3 3/8"	yes	0-4000 rpm	no	Black	white tip
95-0922	3 3/8"	no	0-4000 rpm	yes	Black	white tip
95-0923	3 3/8"	no	0-4000 rpm	yes	Chrome	white tip
95-0921	3 3/8"	no	0-4000 rpm	no	Black	white tip
95-0926	3 3/8"	no	0-4000 rpm	no	Chrome	white tip
95-0908	3 3/8"	yes	0-3000 rpm	yes	Black	white tip
95-0909	3 3/8"	yes	0-3000 rpm	yes	Chrome	white tip
95-0912	3 3/8"	yes	0-3000 rpm	no	Black	white tip
95-0913	3 3/8"	yes	0-3000 rpm	no	Chrome	white tip
95-0906	3 3/8"	no	0-3000 rpm	yes	Black	white tip
95-0907	3 3/8"	no	0-3000 rpm	yes	Chrome	white tip
95-0904	3 3/8"	no	0-3000 rpm	no	Black	white tip
95-0911	3 3/8"	no	0-3000 rpm	no	Chrome	white tip
95-0902	3 3/8"	yes	0-2000 rpm	yes	Black	white tip
95-0903	3 3/8"	yes	0-2000 rpm	no	Black	white tip
95-0901	3 3/8"	no	0-2000 rpm	yes	Black	white tip
95-0900	3 3/8"	no	0-2000 rpm	no	Black	white tip

## 2 1/16" Electronic Tachometers

These tachometers are used in small engine applications such as the 6.2/6.5 liter GM Diesel, 6.9/7.3 Ford Diesel and Dodge/Cummins.

- All units can be used with any sensor kit listed in this section.
- All units are 12 VDC NG only.
- To install sensor, mount two magnets to front engine pulley and sensor to a pan bolt.
- All units have black bezels and red-orange pointers.
- Made in the USA.

Select a tachometer and sensor kit for your application:				Replacement parts for sensor kit at left. Not needed for new installations.	
APPLICATION	RPM	TACH HEAD	SENSOR KIT	MAGNET KIT	SENSOR ONLY
Universal 3K	3K	95-1000	95-1010	95-0180	95-0185
Dodge/Cummins, Pre 92	4K	95-1002	95-1011	95-0180	95-0186
Dodge/Cummins, Pre 92 & later	4K	95-1002	95-1012	N/A	N/A
GM 6.2/6.5 liter	4K	95-1002	95-1013	95-0180	95-0187
Ford 6.9/7.3 liter	4K	95-1002	95-1014	95-0180	95-0188
Universal 4K	4K	95-1002	95-1010	95-0180	95-0185
Universal 5K	5K	95-1003	95-1010	95-0180	95-0185
Volkswagen	5K	95-1003	95-1010	95-0180	N/A
Universal 6K	6K	95-1005	95-1010	95-0180	95-0185



95-1002 2 1/16" Tachometer  
0-4000 rpm, black bezel



95-1011 Sensor kit  
For Dodge/Cummins, pre 92



95-1012 Sensor kit  
For Dodge/Cummins, 92 & later

## 3 3/8" Alternator Tachometers

These products are designed for alternator applications with an alternating current tap and are field adjustable. For 24 VDC NG applications, a 24 VDC bulb must be purchased separately. See Gauge Lighting section on page 30.

- 12 or 24 VDC NG operation.
- Alternator tachs have silicone dampened air core movements.
- Black bezels are standard.
- Made in the USA.

PART NUMBER	SCALE	HOURLY	BEZEL COLOR	POINTER
95-1512	0-8000 rpm	yes	Black	white tip
95-1511	0-8000 rpm	no	Black	white tip
95-1510	0-6000 rpm	yes	Black	white tip
95-1509	0-6000 rpm	no	Black	white tip
95-1507	0-4000 rpm	yes	Black	white tip
95-1504	0-4000 rpm	no	Black	white tip
95-1503	0-3000 rpm	yes	Black	white tip
95-1502	0-3000 rpm	no	Black	white tip
95-1501	0-2000 rpm	yes	Black	white tip
95-1500	0-2000 rpm	no	Black	white tip



95-1500 Alternator tachometer  
3 3/8", 0-2000 rpm, hourmeter



95-1503 Alternator tachometer  
3 3/8", 0-3000 rpm, hourmeter



95-1507 Alternator tachometer  
3 3/8", 0-4000 rpm



95-1509 Alternator tachometer  
3 3/8", 0-6000 rpm

## Hand Held Tachometers

95-0150 Digital Hand Held Tachometer

Measures rotational speeds without mechanical contact on any rotating object. Included are carrying case, batteries and reflective tape. Features:

- Memory
- Rugged lightweight construction
- Accuracy:  $\pm .1$  rpm, 5 to 999.9 rpm
- Accurate digital LCD readout
- Range: 6 to 100,000 rpm
- $\pm 1$  rpm, 1,000 to 100,000 rpm

95-0151 Replacement reflective tape, one 2 ft. piece.



95-0150 Digital hand held  
photo-tachometer



95-1700 Ignition tachometer  
2 1/16", 0-4000 rpm, black bezel



95-1710 Ignition tachometer  
3 3/8", 0-5000 rpm, black bezel



95-1715 Ignition tachometer  
3 3/8", 0-6000 rpm, hourmeter

## Ignition Tachometers

These tachometers are designed for most standard ignition systems that have a coil type ignition or tach output connection. Applications are for 4, 6 or 8 cylinder, four stroke engines. For 24 VDC NG applications, a 24 VDC bulb must be purchased separately. See Gauge Lighting section on page 30.

- Hourmeters reflect true engine running hours.
- 12 or 24 VDC NG operation on 3 3/8" air core units.
- 12 VDC NG only on 2 1/16" units.
- All models include light kit and mounting hardware.
- 2 1/16" units have black bezels and red-orange pointers.
- 3 3/8" units have black bezels and white pointers.

PART NUMBER	SIZE	SCALE	HOURLMETER	BEZEL	POINTER
95-1718	3 3/8"	0-8000 rpm	yes	Black	white tip
95-1716	3 3/8"	0-8000 rpm	no	Black	white tip
95-1715	3 3/8"	0-6000 rpm	yes	Black	white tip
95-1713	3 3/8"	0-6000 rpm	no	Black	white tip
95-1712	3 3/8"	0-5000 rpm	yes	Black	white tip
95-1710	3 3/8"	0-5000 rpm	no	Black	white tip
95-1708	3 3/8"	0-4000 rpm	yes	Black	white tip
95-1706	3 3/8"	0-4000 rpm	no	Black	white tip
AIR CORE MOVEMENT					
95-1702	2 1/16"	0-6000 rpm	no	Black	red-orange tip
95-1701	2 1/16"	0-5000 rpm	no	Black	red-orange tip
95-1700	2 1/16"	0-4000 rpm	no	Black	red-orange tip

## Specialty Devices

### 95-0160 Pulse Distribution Module

This module corrects problems caused by attaching multiple instruments to one magnetic speed sender or pulse generator. It accepts existing speedometer or tachometer signal and will boost and isolate it into five separate outputs. These can be used to drive speedometers, on-board computers, cruise control, taximeters and other devices that use the signal without weak or intermittent signals and interference. 12 VDC NG.

95-0161 Pulse Distribution Module Same as 95-0160 except 24VDC NG.



95-0160 Pulse distribution module

### 95-0162 Electronic Ratio Adapter

This device corrects speedometer accuracy caused by tire size and rear end ratio changes. Instructions help you calculate percentage of increase or decrease necessary to correct the speedometer reading. Dip switches are then set to adjust the signal and calibrate the speedometer. Wiring is 12 VDC NG keyed on/off, ground, input signal from magnetic sensor or signal generator and output signal to the speedometer.



95-0162 Electronic ratio adapter

## Product Specifications

### Mechanical Speedometers & Tachometers

Fit SAE 3 3/8" standard mounting hole, 5" diameter models available.

Speedometer:

Meets SAE J678, ± 2% full scale @ -7°C to 54°C

Odometer:

± 0.3% error @ -7°C to 54°C.

Tachometer:

Meets SAE J678, ± 2% full scale @ -7°C to 54°C

Hourmeter:

± 2% @ 24°C

### Electric Speedometers & Tachometers

Speedometer:

Meets SAE J1226 at ambient, ± 2% full scale @ -7°C to + 54°C

Odometer:

± 0.3% error @ -7°C to + 54°C

Tachometer:

Meets SAE J1399, ± 2% full scale @ -7°C to + 54°C

Hourmeter:

± 1% @ -7°C to + 54°C

## Contents

Engine Shutdowns  
Turbo Temp Monitors  
Low Water Alarms  
Electronic Speed & Exhaust Temperature Switches  
Pressure & Temperature Switches  
Hourmeters  
Heavy Duty Voltmeters & Ammeters  
Gauge Mounting Accessories  
Lighting, Relays, Buzzers & Alarms  
Adapter Bushing Kit  
Water Level Probes & Warning Lights  
Voltage Reducers  
Tubing Kits & Adapter Nuts  
Black Ice Indicator Gauge



## Specialty Products & Accessories



95-6010 Engine shutdown/protection kit



95-6030 Turbo temp monitor



95-6040 Low water alarm kit



95-6042 Low water alarm module



95-6070 Pressure switch 1 stud



95-6072 Pressure switch 2 1/4" blades



95-6077 Pressure switch 2 1/4" blades



95-6076 Pressure switch 2 1/4" blades

## Engine Shutdowns

PART NUMBER	DESCRIPTION
95-6010	Engine Shutdown/Protection Kit for use in mobile applications (trucking, automotive) Solid state engine protection module with 20A(NO) or 10A(NC) contacts to handle heavy switch loads. The kit includes a 12 VDC NG 95-6013 shutdown module (15 second delay for engine starting and 30 second delay before shutdown after alarm), low coolant probe, low oil pressure switch (7-9 PSI), high engine temperature switch (225°F), warning light and buzzer.
95-6011	Engine Shutdown/Protection Kit for stationary engines Same as 95-6010 except for use in 24 VDC NG systems.
95-6012	Engine Shutdown/Protection Kit for stationary engines The kit includes a 12 VDC NG 95-3506 shutdown module (30 second delay to allow engine starting, then immediate shutdown with alarm), low coolant probe, low oil pressure switch (7-9 PSI), high engine temperature switch (225°F), warning light and buzzer. Specifications are the same as 95-6010 shutdown kit but for use in stationary engine applications (immediate shutdown after alarm).
95-6018	Engine Shutdown/Protection Box for stationary engines Same as 95-6012 except for use in 24 VDC NG system.
95-6013	Engine Shutdown/Protection Control Module Control module only for 95-6010 kit. Switches (ground on alarm) and other devices can be added for your specific application. Low water warning uses an AC voltage to eliminate potential plating problems which a DC voltage could cause. Enclosure is anodized metal box with reliable terminal block connections. 12 VDC NG.
95-6014	Engine Shutdown/Protection Control Module Same as 95-6013 except for use in 24 VDC NG systems.
95-6015	Engine Shutdown/Protection Control Module for use in stationary engine applications (generator, pump). Solid state engine protection module with 20A(NO) or 10A(NC) contacts to handle heavy switch loads.
95-6016	Engine Shutdown/Protection Control Module Same as 95-6015 except for use in 24 VDC NG systems.

## Turbo Temp Monitors

PART NUMBER	DESCRIPTION
95-6030	This monitor can help eliminate early turbocharger failure in diesel applications. When engine ignition is turned off, the 95-6030 causes the engine to idle until a safe exhaust temperature is reached, then automatically shuts it down. By shutting down in a cooled condition, deposits are reduced and turbo life is increased. Standard shutdown is 300°F. The existing pyrometer system can be used or order lead wire 95-5165-8 and a type K thermocouple 12 VDC NG.
95-6031	Same as 95-6030 except for use in 24 VDC NG systems.

## Low Water Alarms

PART NUMBER	DESCRIPTION
95-6040	Low Water Alarm Kit Solid state low water alarm uses AC to detect low coolant conditions, thus eliminating potential plating problems. High current relay 20A (NO), 10A (NC) relay will handle most shutdown or alarm circuits. 12 VDC NG version includes probe, warning light and buzzer. Plastic radiators require two probes
95-6041	Low Water Alarm Kit Same as 95-6040 except for use in 24 VDC NG systems.
95-6042	Low Water Alarm Module Control module only for 95-6040 kit. A very commonly used trouble free coolant alarm. 12 VDC NG. Plastic radiators require two probes.
95-6043	Low Water Alarm Module Same as 95-6042 except for use in 24 VDC NG systems.

## Electronic Switches

PART NUMBER	DESCRIPTION
95-6050	Single Level Speed Switch Speed switch will trip at preset rpm to control engine function or other control circuitry. Relay outputs can switch external circuit on or off at trip point. 12 VDC NG. Specify when ordering: sensor or ignition input, latched or auto-reset relay, desired switch point.
95-6051	Single Level Speed Switch - Adjustable Single level speed switch is field adjustable and designed to be used as an over rev alarm or road speed alarm. When setting is exceeded, an audio and visual warning device or shutdown is activated. Accepts signals from Tectran magnetic pickup or signal generator. Set point is adjustable from 100 to 5,000 hertz. 12 VDC NG. Unlatched (auto-reset) design only. When the set point is exceeded the relay will remain tripped until the signal falls below the set point when it will reset. Not compatible with ignition inputs. Use 95-6051, factory preset to your specs, for latched applications.
95-6052	Single Level Speed Switch - Adjustable Same as 95-6051 except for use in 24 VDC NG systems.
95-6053	Dual Level Speed Switch Same as 95-6050 except with dual switch point, one upper and one lower. Specify two set points when ordering, as well as 12 or 24 VDC NG, sensor or ignition input, latched or auto-reset relay.
95-6054	Dual Level Speed Switch Same as 95-6053 except for use in 24 VDC NG systems.
95-6055	Two Level Temperature Switch Designed to give a two step warning when predetermined exhaust temperatures are reached. When step one is reached, a warning light will come on, when step two is reached, additional warnings or controls will activate. 12 VDC NG. Alarm points must be specified for factory setting.
95-6056	Two Level Temperature Switch Same as 95-6055 except for use in 24 VDC NG systems.



95-6051 Single level speed switch



95-6055 Two level temperature switch



95-6079 Pressure switch  
3 1/4" blades



95-6081 Pressure switch  
1 stud



95-6090 Temperature switch  
1 stud



95-6091 Temperature switch  
1 stud



95-6094 Temperature switch  
2 blades



95-6099 Temperature switch  
1 stud

## Pressure & Temperature Switches

Rugged and reliable for indicator light, relays, hourmeters, etc. Switches can be supplied for custom applications. Contact factory for details. All pressure switches have a six amp capacity except 95-6070 and 95-6071 which have a three amp capacity. All temperature switches have a one amp capacity.

### PRESSURE SWITCHES-ALL HAVE 1/8" NPTF THREAD

PART NUMBER	SETTING	TYPE	TERMINALS	PART NUMBER	SETTING	TYPE	TERMINALS
95-6070	15 psi	N/C	1 stud	95-6075	15 psi	N/C, HD	2 1/4" blades
95-6071	6 psi	N/C	1 stud	95-6077	60 psi	N/O, HD	2 1/4" blades
95-6072	4 psi	N/O, HD	2 1/4" blades	95-6078	60 psi	N/C, HD	2 1/4" blades
95-6073	4 psi	N/C, HD	2 1/4" blades	95-6079	4 psi	N/C & O, HD	3 1/4" blades
95-6074	15 psi	N/O, HD	2 1/4" blades	95-6080	4 psi	N/O	1 stud
95-6076	8 psi	N/C, HD	2 1/4" blades	95-6081	8 psi	N/C	1 stud

### TEMPERATURE SWITCHES-NORMALLY OPEN

PART NUMBER	SETTING	TYPE	TERMINALS	PART NUMBER	SETTING	TYPE	TERMINALS
95-6090	250°F	1/4" NPTF	1 stud	95-6096	200°F	3/8" NPTF	1 stud
95-6091	255°F	1/4" NPTF	1 stud	95-6097	200°F	1/2" NPTF	1 stud
95-6092	212°F	1/2" NPTF	1 stud	95-6098	225°F	1/2" NPTF	1 stud
95-6093	200°F	1/4" NPTF	1 stud	95-6099	250°F	1/2" NPTF	1 stud
95-6094	200°F	1/4" NPTF	2 blades				

Specialty Products & Accessories



95-6302 Hourmeter stainless bezel



95-6305 Hourmeter black bezel



95-6308 Hourmeter digital display



95-6306 Hourmeter rectangular mini-meter, black finish



95-6320 Heavy duty voltmeter 7-18 VDC scale, black bezel



95-6150 Mounting bracket black finish



95-6173 Swivel mounting bracket for 3" gauges

## Hourmeters

Tectran's standard range is 10/80 VDC. 4-40 VDC meters are available by special order.

- The 95-6308 digital hourmeter is designed with solid state memory which retains its reading when voltage is removed.
- Standard 2 1/16" mounting diameter except 95-6306 and 95-6307, which are rectangular.
- Made in the USA.

PART NUMBER	VOLTS	BEZEL	STYLE
95-6300	4-40 VDC	Black	snap on clamp
95-6301	10-80 VDC	Black	snap on clamp
95-6302	4-40 VDC	Stainless	snap on clamp
95-6303	10-80 VDC	Stainless	snap on clamp
95-6304	4-40 VDC	Black	SAE 3 hole
95-6305	10-80 VDC	Black	SAE 3 hole
95-6306	4-40 VDC	Black	rectangular mini-meter
95-6307	10-80 VDC	Black	rectangular mini-meter
95-6308	9-30 VDC	Black	digital display with clamp

## 2 1/16" Heavy Duty Full Sweep Voltmeters & Ammeters

These meters are used in applications where precision readings are required. Bezels and face dials do not match our regular gauges.

- 2 1/16" mounting diameter is standard
- Red-orange pointer, 250° sweep and black bezel is standard

PART NUMBER	TYPE
95-6320	Voltmeter, 7-18 VDC scale
95-6321	Ammeter/shunt 100-0-100 scale
95-6323	Ammeter/shunt 150-0-150 scale
95-6324	Ammeter/shunt 200-0-200 scale
95-6325	Ammeter/shunt 300-0-300 scale

## Gauge Mounting Accessories

MOUNTING BRACKETS			
BLACK BEZEL	CHROME BEZEL	NUMBER OF GAUGES	GAUGE DIAMETER
95-6150	N/A	1	3"
95-6151	95-6156	1	2 1/16"
95-6152	95-6157	2	2 1/16"
95-6153	95-6158	3	2 1/16"
95-6154	95-6159	4	2 1/16"
95-6155	95-6160	1	3 3/8"

MISCELLANEOUS CUPS & BRACKETS				
BLACK BEZEL	CHROME BEZEL	SIZE	FINISH	DESCRIPTION
95-6161	95-6162	3 3/8"	Black/Chrome	Tachs and speedometers
95-6163	95-6164	2 1/16"	Black/Chrome	All 2 1/16" gauges
95-6166	95-6167	3"	Black/Chrome	Pyrometer only
95-6170	N/A	5"	Black	All 5" gauges
N/A	95-6173	3"	Zinc Plated	Swivel mounting bracket



## Gauge Lighting

MISCELLANEOUS CUPS & BRACKETS				
PART NUMBER	TYPE OF ASSEMBLY	WIRES	BULB NUMBER	MOUNTING DIAMETER
95-6200	Gauge light	2 wires	12V - #53 24V - #356	5/8" short depth
95-6201	Gauge light	1 wire ground to gauge	12V - #53 24V - #356 32V - #1822 36V - #1828	9/16" & 5/8" universal most gauges
95-6202	Gauge light	2 wires	12V - #161 24V - #656	9/16" & 5/8" universal, most gauges
95-6203	Wedge base light - twist in	N/A	12V - #161 24V - #656	twist in assembly
95-6204	Gauge light	1 wire	14V - #1893	9/16" & 5/8"



95-6200 Gauge light  
2 wires



95-6203 Gauge light  
wedge base light

## Relays, Buzzers & Alarms

PART NUMBER	TYPE	VOLTS	MISCELLANEOUS
95-6215	Relay	12	20 amp with connector
95-6216	Buzzer	12	
95-6217	Buzzer	12 or 24	steady tone
95-6218	Buzzer	12 or 24	pulse tone
95-6220	Alarm	12 or 24	103 DBA
95-6221	Buzzer & Light	12	



95-6215 Relay  
12 VDC NG



95-6218 Buzzer  
pulse tone

## Adapter Bushing Kit

For electric pressure senders and some temperature senders.

PART NUMBER	DESCRIPTION
95-6290	Metric adapter fitting Includes M10 x 1.0, M12 x 1.5, M14 x 1.5, M16 x 1.5 and M18 x 1.5 to 1/8" NPTF adapters.



95-6290 Metric adapter kit

## Water Level Probes

PART NUMBER	TYPE
95-6230	Sensor, 2.36" extension beyond threads
95-6231	Sensor, 1.36" extension beyond threads



95-6230, 95-6231  
Water Level Probes

## Warning Lights

PART NUMBER	COLOR/MARKING
95-6240	Red - no marking
95-6241	Red - marked LOW WTR



95-6240 Warning light red,  
no marking



95-6250 Voltage Reducer



95-6261 Tubing Kit  
Oil pressure, 10 feet



95-6264 Tubing kit  
Vacuum, 6 feet



95-6270 Adapter nut  
1/2" NPTF



95-6285 Black ice indicator gauge  
2 1/16", black pedestal mounting  
(removable)

## Voltage Reducers/Gauge Voltage Dropping Resistors

Voltage reducers are not designed for light bulb applications.

PART NUMBER	USE
95-6251	For 32 - 12 VDC NG gauges. Use one for each gauge.
95-6250	For 24 - 12 VDC NG gauges. Use one for each gauge.

## Tubing Kits

PART NUMBER	TYPE	LENGTH
95-6260	Oil Pressure, Manifold Pressure, Boost	6 feet
95-6261	Oil Pressure	10 feet
95-6264	Manifold Vacuum	6 feet
95-6265	Oil Pressure	16 feet

Custom length kits are also available.

## Adapter Nuts

For mechanical temperature gauges. Adapts capillary tube to male thread size shown.

PART NUMBER	LENGTH
95-6270	1/2" NPTF
95-6271	3/8" NPTF
95-6272	1/4" NPTF
95-6273	5/8"-18 UNF

## Black Ice Indicator

Indicates ice-forming temperatures exist outside the vehicle. Red LED indicates temperatures at or below freezing, warning of potentially dangerous road conditions. Standard with pedestal mounting. Pedestal mounting removable for mounting into typical 2 1/16" dash mounting hole. Includes internal lighting, sensor for mounting outside vehicle and all necessary mounting hardware. For use in 12 VDC NG systems. Operating range: -20°F to 100°F.

PART NUMBER	SPECS
95-6285	Black ice indicator
95-6286	Replacement lamp for 95-6285
95-6287	Replacement sensor for 95-6285

## Index by Part Number

Part No.	Pg.	Part No.	Pg.	Part No.	Pg.	Part No.	Pg.	Part No.	Pg.	Part No.	Pg.	Part No.	Pg.	Part No.	Pg.
95-0010	21	95-0406	19	95-1000	24	95-2401	3	95-2670	6	95-3036	8	95-5076	13	95-6093	28
95-0011	21	95-0407	19	95-1002	24	95-2404	3	95-2671	6	95-3037	8	95-5079	13	95-6094	28
95-0012	21	95-0408	19	95-1003	24	95-2407	3	95-2672	6	95-3038	8	95-5085	13	95-6096	28
95-0013	21	95-0409	19	95-1005	24	95-2425	3	95-2673	6	95-3039	8	95-5088	13	95-6097	28
95-0014	21	95-0410	19	95-1010	24	95-2427	3	95-2674	6	95-3040	8	95-5090	13	95-6098	28
95-0015	21	95-0412	19	95-1011	24	95-2432	3	95-2675	6	95-3041	8	95-5100	13	95-6099	28
95-0016	21	95-0413	19	95-1012	24	95-2450	4	95-2695	6	95-3042	8	95-5120	15	95-6150	29
95-0017	21	95-0423	19	95-1013	24	95-2451	4	95-2696	6	95-3044	8	95-5121	15	95-6151	29
95-0030	21	95-0424	19	95-1014	24	95-2452	4	95-2697	6	95-3050	8	95-5123	15	95-6152	29
95-0031	21	95-0500	20	95-1500	24	95-2453	4	95-2698	6	95-3051	8	95-5124	15	95-6153	29
95-0040	21	95-0501	20	95-1501	24	95-2454	4	95-2699	6	95-3055	8	95-5125	15	95-6154	29
95-0041	21	95-0502	20	95-1502	24	95-2455	4	95-2700	6	95-3056	8	95-5126	15,16	95-6155	29
95-0042	21	95-0504	20	95-1503	24	95-2460	4	95-2701	6	95-3057	8	95-5127	15	95-6156	29
95-0043	21	95-0505	20	95-1504	24	95-2461	4	95-2702	6	95-3058	8	95-5128	15	95-6157	29
95-0044	21	95-0510	20	95-1507	24	95-2462	4	95-2704	6	95-3059	8	95-5129	15	95-6158	29
95-0048	21	95-0511	20	95-1509	24	95-2463	4	95-2705	6	95-3070	8	95-5130	15	95-6159	29
95-0049	21	95-0512	20	95-1510	24	95-2464	4	95-2706	6	95-3071	8	95-5131	15	95-6160	29
95-0050	21	95-0513	20	95-1511	24	95-2465	4	95-2707	6	95-3072	8	95-5132	15	95-6161	29
95-0051	21	95-0514	20	95-1512	24	95-2466	4	95-2740	7	95-3100	10	95-5133	15	95-6162	29
95-0060	22	95-0516	20	95-1700	25	95-2467	4	95-2741	7	95-3101	10	95-5134	15	95-6163	29
95-0061	22	95-0518	20	95-1701	25	95-2468	4	95-2742	7	95-3102	10	95-5135	15	95-6164	29
95-0062	22	95-0519	20	95-1702	25	95-2475	4	95-2743	7	95-3103	10	95-5136	15	95-6166	29
95-0063	22	95-0520	20,25	95-1706	25	95-2476	4	95-2744	7	95-3104	10	95-5137	15	95-6167	29
95-0064	22	95-0521	20	95-1708	25	95-2477	4	95-2747	7	95-3105	10	95-5138	15	95-6170	29
95-0065	22	95-0522	20	95-1710	25	95-2478	4	95-2748	7	95-3106	10	95-5155	16	95-6173	29
95-0067	22	95-0523	20	95-1712	25	95-2479	4	95-2749	7	95-3107	10	95-5156	16	95-6200	30
95-0068	22	95-0524	20	95-1713	25	95-2480	4	95-2752	7	95-3108	10	95-5157	16	95-6201	30
95-0069	22	95-0525	20	95-1715	25	95-2481	4	95-2753	7	95-3120	10	95-5158	16	95-6202	30
95-0070	22	95-0526	20	95-1716	25	95-2484	4	95-2754	7	95-3121	10	95-5160	16	95-6203	30
95-0071	22	95-0527	20	95-1718	25	95-2485	4	95-2756	7	95-3122	10	95-5165	15	95-6204	30
95-0072	22	95-0528	20	95-2200	2	95-2486	4	95-2757	7	95-3123	10	95-5169	15	95-6215	30
95-0073	22	95-0541	20	95-2201	2	95-2487	4	95-2758	7	95-3124	10	95-5173	15	95-6216	30
95-0074	22	95-0700	21	95-2202	2	95-2488	4	95-2759	7	95-3300	9	95-5174	15	95-6217	30
95-0075	22	95-0701	21	95-2206	2	95-2490	4	95-2760	7	95-3301	9	95-5175	15	95-6218	30
95-0076	22	95-0704	21	95-2207	2	95-2530	4	95-2761	7	95-3302	9	95-5176	15	95-6220	30
95-0077	22	95-0705	21	95-2208	2	95-2531	4	95-2764	7	95-3303	9	95-5221	16	95-6221	30
95-0078	22	95-0706	21	95-2209	2	95-2534	4	95-2765	7	95-3304	9	95-5242	12	95-6230	30
95-0081	22	95-0707	21	95-2215	2	95-2535	4	95-2766	7	95-3305	9	95-5243	12	95-6231	30
95-0083	22	95-0708	21	95-2216	2	95-2540	4	95-2768	7	95-3306	9	95-6010	27	95-6240	30
95-0084	22	95-0709	21	95-2221	2	95-2541	4	95-2769	7	95-3307	9	95-6011	27	95-6241	30
95-0085	22	95-0710	21	95-2230	2	95-2544	4	95-2770	7	95-3308	9	95-6012	27	95-6250	31
95-0088	22	95-0711	21	95-2231	2	95-2545	4	95-2771	7	95-3309	9	95-6013	27	95-6251	31
95-0089	22	95-0712	21	95-2232	2	95-2570	5	95-2788	7	95-3310	9	95-6014	27	95-6260	31
95-0090	22	95-0713	21	95-2235	2	95-2571	5	95-2792	7	95-3311	9	95-6015	27	95-6261	31
95-0093	22	95-0715	21	95-2236	2	95-2574	5	95-2845	6	95-3312	9	95-6016	27	95-6264	31
95-0096	22	95-0717	21	95-2270	2	95-2575	5	95-2846	6	95-3313	9	95-6018	27	95-6265	31
95-0098	22	95-0900	23	95-2272	2	95-2578	5	95-2847	6	95-3314	9	95-6030	27	95-6270	31
95-0100	22	95-0901	23	95-2280	2	95-2579	5	95-2849	6	95-3315	9	95-6031	27	95-6271	31
95-0102	22	95-0902	23	95-2282	2	95-2580	5	95-2856	6	95-3316	9	95-6040	27	95-6272	31
95-0103	22	95-0903	23	95-2285	2	95-2583	5	95-2857	6	95-3317	9	95-6041	27	95-6273	31
95-0104	22	95-0904	23	95-2300	3	95-2584	5	95-2875	4	95-3318	9	95-6042	27	95-6285	31
95-0105	22	95-0906	23	95-2301	3	95-2587	5	95-2876	4	95-3319	9	95-6043	27	95-6286	31
95-0106	22	95-0907	23	95-2302	3	95-2589	5	95-2878	4	95-3320	9	95-6050	28	95-6287	31
95-0107	22	95-0908	23	95-2303	3	95-2590	5	95-2879	4	95-3321	9	95-6051	28	95-6290	30
95-0108	22	95-0909	23	95-2306	3	95-2591	5	95-3000	7	95-3322	9	95-6052	28	95-6300	29
95-0110	22	95-0911	23	95-2307	3	95-2592	5	95-3001	7	95-3323	9	95-6053	28	95-6301	29
95-0112	22	95-0912	23	95-2309	3	95-2593	5	95-3002	7	95-3324	9	95-6054	28	95-6302	29
95-0140	22	95-0913	23	95-2312	3	95-2594	5	95-3003	7	95-3325	9	95-6055	28	95-6303	29
95-0141	22	95-0914	23	95-2313	3	95-2596	5	95-3004	7	95-3326	9	95-6056	28	95-6304	29
95-0142	22	95-0915	23	95-2320	3	95-2630	5	95-3005	7	95-3327	9	95-6070	27,28	95-6305	29
95-0150	24	95-0916	23	95-2335	2	95-2631	5	95-3006	7	95-3328	9	95-6071	28	95-6306	29
95-0151	24	95-0917	23	95-2336	2	95-2634	5	95-3007	7	95-3329	9	95-6072	27,28	95-6307	29
95-0160	25	95-0920	23	95-2345	3	95-2635	5	95-3008	7	95-5000	12	95-6073	28	95-6308	29
95-0161	25	95-0921	23	95-2348	3	95-2636	5	95-3009	7	95-5006	12	95-6074	28	95-6320	29
95-0162	25	95-0922	23	95-2349	3	95-2639	5	95-3020	8	95-5007	12	95-6075	28	95-6321	29
95-0180	24	95-0923	23	95-2350	3	95-2640	5	95-3021	8	95-5013	12	95-6076	27,28	95-6323	29
95-0185	24	95-0924	23	95-2365	3	95-2660	6	95-3022	8	95-5014	12	95-6077	27,28	95-6324	29
95-0186	24	95-0926	23	95-2366	3	95-2661	6	95-3023	8	95-5016	12	95-6078	28	95-6325	29
95-0187	24	95-0927	23	95-2369	3	95-2662	6	95-3024	8	95-5019	12	95-6079	28		
95-0188	24	95-0929	23	95-2375	3	95-2663	6	95-3025	8	95-5030	13	95-6080	28		
95-0400	19	95-0930	23,25	95-2376	3	95-2664	6	95-3026	8	95-5040	13	95-6081	28		
95-0402	19	95-0931	23	95-2382	3	95-2665	6	95-3027	8	95-5048	13	95-6090	28		
95-0404	19	95-0932	23	95-2384	3	95-2666	6	95-3028	8	95-5049	13	95-6091	28		
95-0405	19	95-0934	23	95-2400	3	95-2667	6	95-3035	8	95-5054	13	95-6092	28		