

TALL-SIZE/MID-SIZE/SHORT-SIZE HD HEADACHE RACK

PARTS LIST:

1	Tall-Size/Mid-Size/Short-size HD Headache Rack	16	10mm Lock Washers
1	Driver/Left Side Mounting Bracket	12	10mm Hex Nuts
1	Passenger/Right Side Mounting Bracket	4	10mm Nylon Lock Nuts
1	Rear window louvered Access Panel	2	Light Plates
4	10mm x 25mm Button Head Bolts	2	Blank Cover Plates
1	6mm Allen Wrench (10mm)	8	6mm Button Head Combo Bolts
2	Special 10mm "J" Bolts	1	Allen Wrench (4mm)
4	10mm x 80mm Half-thread Hex Bolts	12	4mm x 15mm Button Head Bolts
10	10-1.5mm x 40mm Hex Bolts	24	4mm x 12mm x 1mm Flat Washer
2	12mm x 37mm x 3mm Flat Washers	12	4mm Nylon Lock Nuts
6	10mm x 34mm x 3mm Flat Washers (Large)	1	2.5mm Allen Wrench
34	10mm x 24mm x 2.2mm Flat Washers (Small)	4	Rubber grommets (for light wiring)
		6	10mm Plastic Insulating Washers (Use with Ford aluminum beds ONLY)

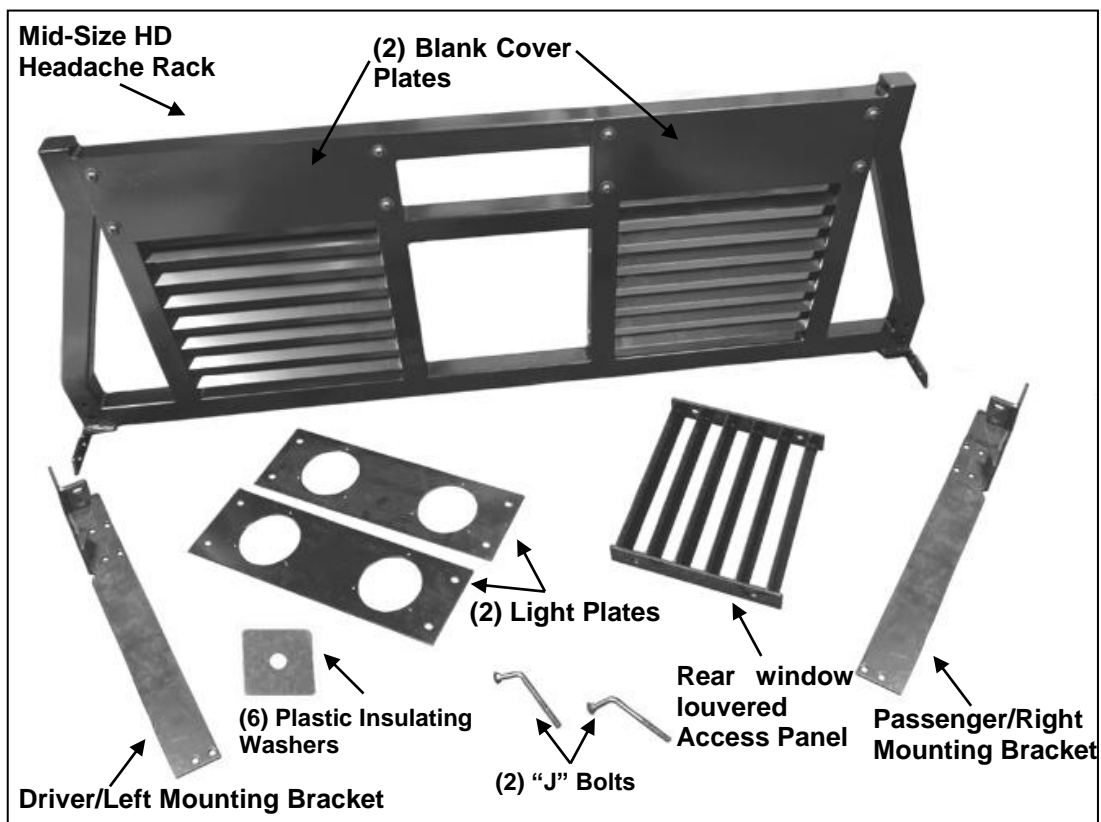

REMOVE CONTENTS FROM BOX. VERIFY ALL PARTS ARE PRESENT. READ INSTRUCTIONS CAREFULLY BEFORE STARTING INSTALLATION. DRILLING IS REQUIRED. ASSISTANCE IS RECOMMENDED. CUTTING OF PLASTIC BED LINER (IF EQUIPPED) MAY BE REQUIRED.

1. Determine if the rear window Access Panel will be installed, (optional).

If Access Panel will be installed:

- a. Place the Headache Rack and Rear Panel on a clean, flat work surface. Line up the louvers in the Access Panel with the louvers on the Headache Rack.
- b. Attach the Panel to the Headache Rack with (4) 10mm Button Head Bolts, (4) 10mm Lock Washers and (4) 10mm x 24mm Flat Washers, (**Figure 1**).
- c. Fully tighten hardware at this time.

TALL-SIZE/MID-SIZE/SHORT-SIZE HD HEADACHE RACK

- Determine if lights will be installed.

If lights will not be installed at this time:

- Select the Blank Cover Plates. Attach the Covers to the openings in the Headache Rack with the included (8) 6mm Button Head Combo Bolts, **(Figures 2 & 3)**.
- Tighten hardware and proceed to **Step 3**.

If lights will be installed, (lights not included):

- Replace the rubber plug in the upright with the included rubber grommet. **NOTE:** Either outer upright on the Headache Rack is suitable for running internal electrical wiring.
 - Select (2) Light Plates. Use the provided (12) 4mm Button Head Bolts, (24) 4mm Flat Washers and (12) 4mm Nylon Lock Nuts to attach the (4) lights to the Light Plates.
 - Attach the (2) Plates to the Rack with the included (8) 6mm Button Head Combo Bolts. Leave hardware loose until ready to attach electrical wiring to lights.
 - Replace the rubber plugs on the bottom crossbar of the Headache Rack with the included rubber grommets.
- Select the passenger side Mounting Bracket. Attach the Bracket to the tab using (2) 10mm x 40mm Hex Bolts, (4) 10mm x 24mm Flat Washers, (2) 10mm Lock Washers and (2) 10mm Hex Nuts, **(Figure 4 & 5)**. Attach the Bracket to the Headache Rack Upright using (2) 10mm x 80mm Hex Bolts, (4) 10mm x 24mm Flat Washers, (2) 10mm Lock Washers and (2) 10mm hex Nuts, **(Figure 4 & 5)**. Snug but do not fully tighten hardware at this time.
 - Repeat the previous Step to attach the driver side Mounting Bracket to the Headache Rack.
 - With assistance, carefully place the Headache Rack onto the approximate mounting position at the front end of the truck bed. Line up the forward end of the Brackets with the end of the bed.
 - Determine if the forward holes in the Brackets line up with the front stake pockets. **NOTE:** On some vehicles, the front stake pocket may be covered with a plastic bed cap. Remove or cut out the cover as required to gain access to the stake pocket, **(Figure 6)**.

If forward holes line up with stake pocket:

- On most vehicles, the forward holes in the Mounting Bracket will line up with or close to the forward stake pockets. On these vehicles, select (1) 10mm "J" Bolt and (1) 12mm Flat Washer, **(Figure 7)**. Slide the Flat Washer over the "J" Bolt down to the head on the bolt. Insert the "J" Bolt into the hole in the side of the stake pocket and up and out the hole in the Bracket, **(Figure 8)**. **NOTE:** "J" Bolts are provided for use in some but not all installations. Do not use the "J" Bolts if the bolt is too short to reach up through the Mounting Bracket or if the pocket does not have access holes in a usable location.
 - Secure the Bracket to the "J" Bolt with (1) 10mm Small Flat Washer, (1) 10mm Lock Washer and (1) 10mm Hex Nut, **(Figure 13)**. Do not fully tighten hardware at this time.
 - Repeat to install the "J" Bolt on the driver side, (if possible).
 - Proceed to **Step 7** for additional drilling and bolting information. **IMPORTANT: Do not attach the Headache Rack with only the "J" Bolts! Additional hardware is required and drilling is mandatory.**
- With the Headache Rack properly positioned on the top of the bed, locate the best location to drill. Use the provided holes in the Brackets if possible, **(Figure 9)**. Do not drill the top of the bed until you have made absolutely sure that you can gain access to the bottom of the mounting locations. **(Figure 10)**.
 - Use the pre-punched holes in the Bracket if possible. If you are using the "J" Bolts, only mark the rear mounting location on the top of the bed, **(Figure 9)**. If "J" Bolts are not used, mark the forward and rear mounting locations, **(Figure 11)**.
 - Each mounting location on the Bracket has (2) holes. Use the holes in the center if possible to better support the Rack. The holes toward the inner edge of the Bracket are

TALL-SIZE/MID-SIZE/SHORT-SIZE HD HEADACHE RACK

provided for models with inner panels on the bed and a narrow mounting surface along the top edge.

8. The provided mounting holes in the Brackets will allow installation on most but not all vehicles. If the holes are not in the correct location for your particular model, drill new mounting holes through the Bracket and top of the bed as necessary for best possible fit, **(Figures 11 & 12)**.
9. On some models, the location of the inner stake pocket interferes with the forward mounting holes. For additional support, drill an additional hole at the front of the Bracket, **(Figures 11 & 12)**. Additional hardware has been provided to bolt the Brackets to the front of the bed.
10. Once all locations have been checked and the holes marked on the top of the bed, remove the Headache Rack assembly. Drill the required holes as marked with a 7/16" drill bit. Reinstall the Headache Rack and attach the Bracket to each mounting hole with (1) 10mm Hex Bolt, (1) 10mm x 24mm Small Flat Washer, (1) 10mm x 24mm Small Flat Washer or (1) 10mm x 34mm Large Flat Washer, (1) 10mm Lock Washer and (1) 10mm Hex Nut, **(Figure 13)**.
 - a. **IMPORTANT:** To help support the Headache Rack, 10mm x 34mm Large Flat Washers have been provided. Use the Large Flat Washers under the top of the bed if possible. Use the Small Flat Washers if there is insufficient room.
 - b. **IMPORTANT SPECIAL NOTE for 2015-on Ford F150, 2017-on Ford Super Duty only:** (6) 10mm Plastic Insulating Washers have been included to insulate the aluminum bed from the steel 10mm Flat Washers. Insert the Plastic Washers between the underside of the bed and the 10mm Flat Washer, **(Figure 13)**.
11. On models with lights installed, **(Step 2)**, Follow the light manufacturer's instructions to properly attach the lights to the vehicle's electrical system.
12. Center the Headache Rack on the truck, check the alignment and tighten all hardware.
13. Do periodic inspections to the installation to make sure that all hardware is secure and tight.

To protect your investment, wax this product after installing. Regular waxing is recommended to add a protective layer over the finish. Do not use any type of polish or wax that may contain abrasives that could damage the finish.

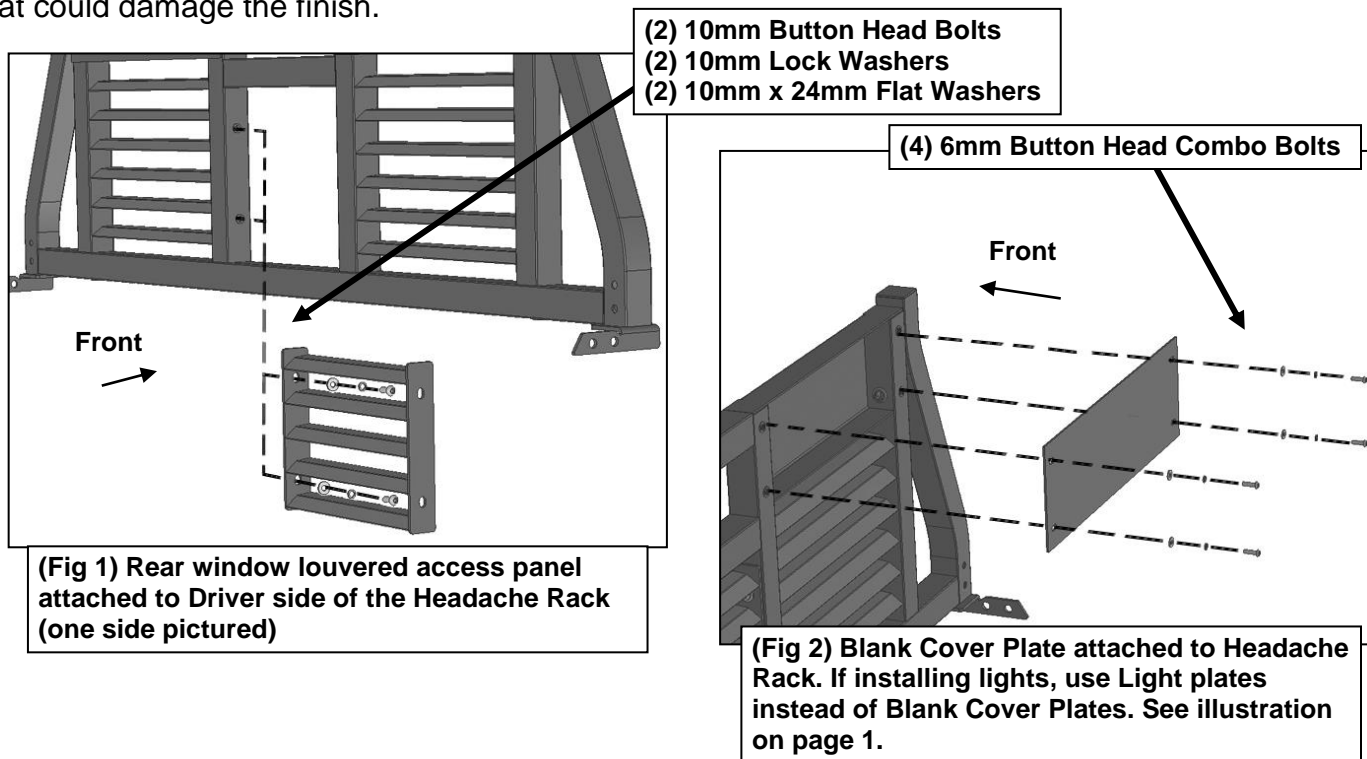

TALL-SIZE/MID-SIZE/SHORT-SIZE HD HEADACHE RACK



(Fig 3) Rear window louvered Access Panel and Plates assembled to Headache Rack

- (2) 10mm x 80mm Hex Bolts
- (4) 10mm x 24mm Flat Washers
- (2) 10mm Lock Washers
- (2) 10mm Hex Nuts



(Fig 5) Passenger side Mounting Bracket attached to Headache Rack pictured

- (2) 10mm x 40mm Hex Bolts
- (4) 10mm x 24mm Flat Washers
- (2) 10mm Lock Washers
- (2) 10mm Hex Nuts

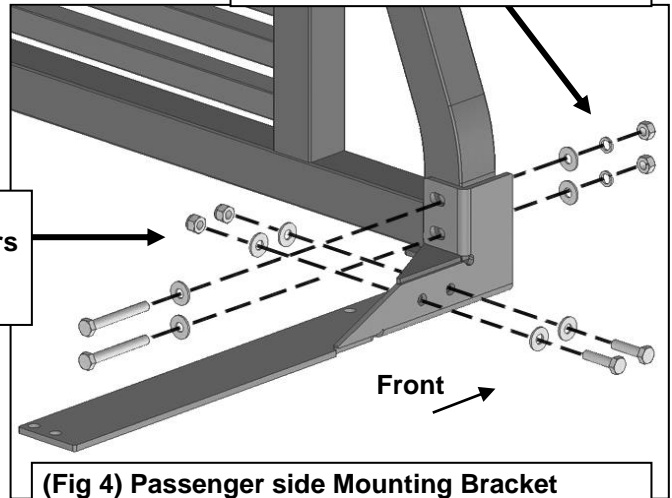

(Fig 4) Passenger side Mounting Bracket attached to Headache Rack assembly

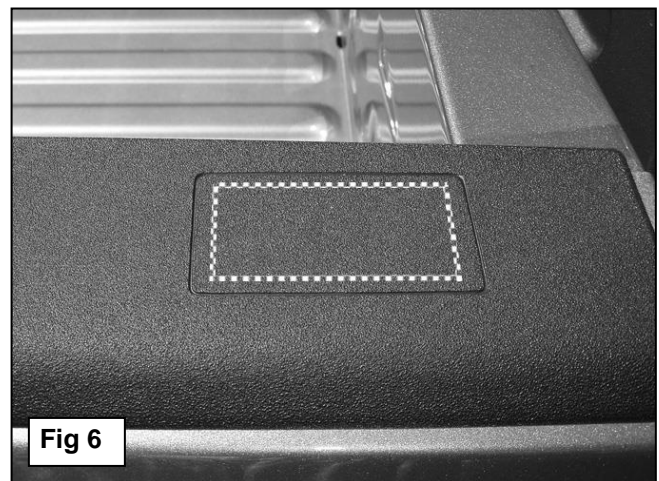

Fig 6

TALL-SIZE/MID-SIZE/SHORT-SIZE HD HEADACHE RACK



(Fig 7) 10mm "J" Bolt w/12mm Flat Washer

Do not use "J" Bolts if the bolt does not extend through the Bracket or if there are no accessible holes in the stake pocket as pictured in example. J-Bolts are not mandatory for installation.



(Fig 8) Use the "J" Bolt to secure the front mounting holes on the Bracket to the stake pocket if possible. Do not drill any mounting holes until after all mounting locations are checked for clearance

Line up appropriate hole in Bracket with "J" Bolt

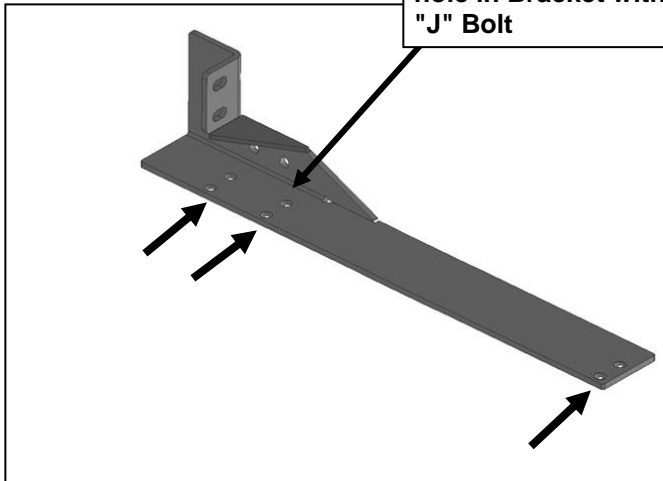

(Fig 9) Insert 10mm "J" Bolt with 12mm Flat Washer into hole in side of stake pocket and up through opening and appropriate hole in the Bracket.



(Fig 10) Before drilling any holes through the top of the bed, check the bottom of the top edge of the bed for hardware clearance.

TALL-SIZE/MID-SIZE/SHORT-SIZE HD HEADACHE RACK

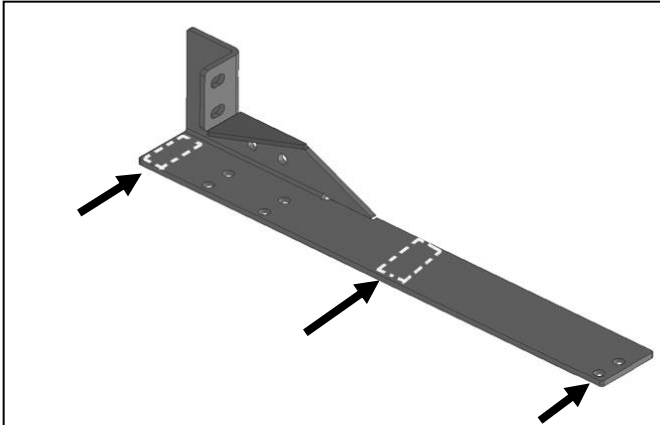

(Fig 11) If the forward hole in the Bracket does not line up with the stake pocket or the J Bolt will not fit properly, drill the necessary holes and bolt the Bracket directly to the top of the bed.

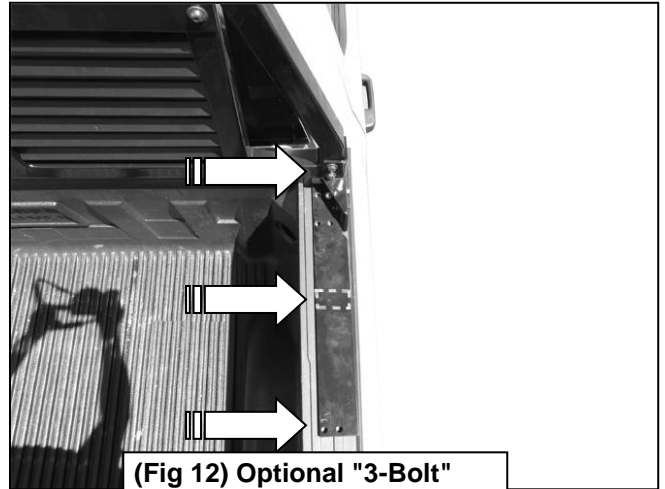

(Fig 12) Optional "3-Bolt" per side installation

- 10mm x 24mm Flat Washer
- 10mm Lock Washer
- 10mm Hex Nut

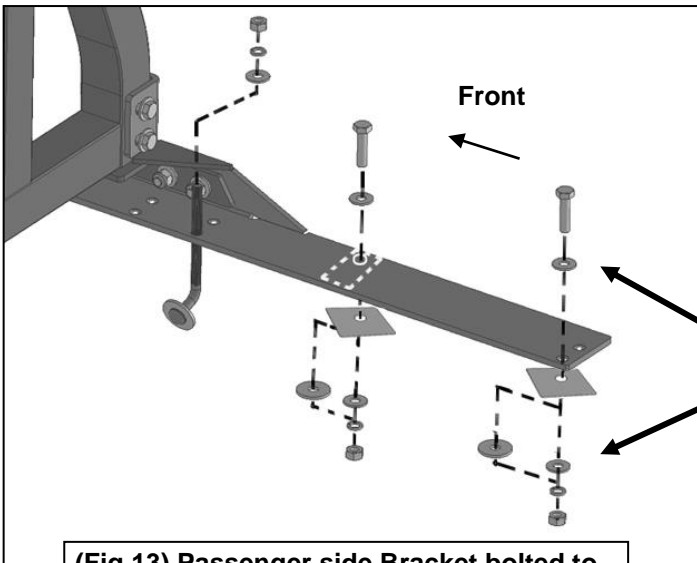

(Fig 13) Passenger side Bracket bolted to vehicle assembly (one possible example)

IMPORTANT: Use the 10mm Plastic Insulating Washers ONLY with Ford aluminum beds.

- (1) 10mm Hex Bolt
- (1) 10mm Small Flat Washer (top)
- (1) 10mm Plastic Washer (Use with Ford aluminum beds ONLY)
- (1) 10mm Large or Small Flat Washer (bottom)
- (1) 10mm Lock Washer
- (1) 10mm Hex Nut

NOTE: Use the appropriate Flat Washer on the bottom of the bed rail as seen fit for vehicle.