

PARTS LIST:

1	Bull Bar	4	10mm Lock Washers
1	Driver/Left Mounting Bracket	4	10-1.5mm Hex Nuts
1	Passenger/Right Mounting Bracket	4	6-1.0mm x 20mm Button Head Bolts
2	Light Brackets	4	6mm x 18mm OD x 1.6mm Flat Washers
4	10-1.5mm x 30mm Hex Bolts	4	6mm Lock Washers
8	10mm x 27mm x 3mm Flat Washers		

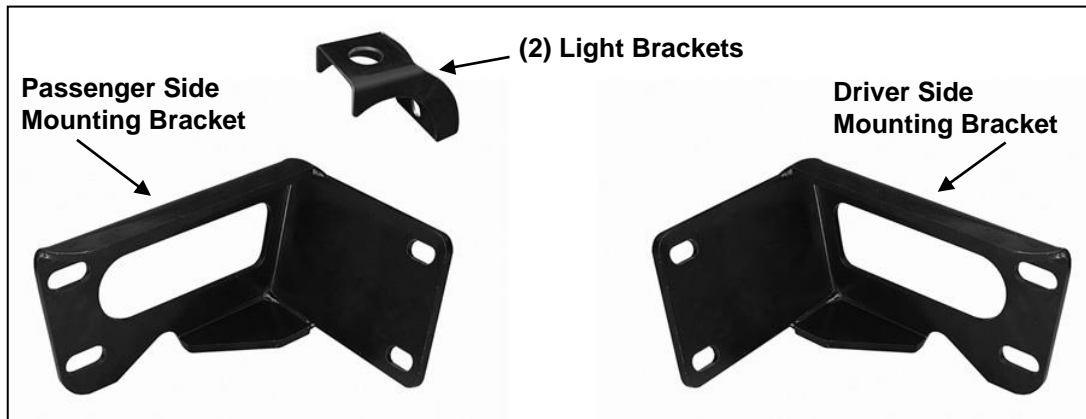

PROCEDURE:

- 1. REMOVE CONTENTS FROM BOX. VERIFY ALL PARTS ARE PRESENT. READ INSTRUCTIONS CAREFULLY BEFORE STARTING INSTALLATION. ASSISTANCE IS RECOMMENDED.**
- 2. NOTE:** It may be necessary to remove/relocate front license plate and bracket. It is not required, but strongly recommended. If local/state law requires a license plate, license plate relocation kit is available.
- Measure the gap between bottom of the headlight assembly and the top of the bumper on the driver and passenger side. Record these measurements for bumper realignment as necessary, **(Step 9)**.
- Start installation at the passenger side, front of the vehicle. Remove the (2) passenger side bumper bolts and double nut plate behind the bumper, **(Figures 1 & 2)**. **WARNING!** Do not loosen or remove the passenger and driver side bumper mounting bolts at the same time or bumper may move out of alignment or fall off of the vehicle. Only remove the bumper bolts from one side and install one Mounting Bracket at a time.
- Place the passenger side Mounting Bracket onto the vehicle, **(Figure 3)**, and line up the (2) slots with the (2) holes for the bumper bolts. Insert the factory bumper bolts through the Bracket, bumper and into the double nut plate, **(Figure 4)**. **NOTE:** Leave a minimum 1/8" clearance between the top or bottom of the Bracket and the bumper. Fully tighten the bumper bolts at this time.
- Repeat **Steps 4—5** for driver side Mounting Bracket installation.
- With assistance, position the Bull Bar onto the outside of the (2) Mounting Brackets. **NOTE:** Move the Mounting Brackets in or out as required to line up with the mounting tabs on the Bull Bar.
- Attach the Bull Bar to the Mounting Brackets using the included (4) 10mm x 30mm Hex Bolts, (8) 10mm Flat Washers, (4) 10mm Lock Washers and (4) 10mm Hex Nuts, **(Figure 5)**. Snug but do not tighten hardware at this time.
- Center the Bull Bar on the vehicle, level and adjust as desired and tighten all hardware at this time. Check front bumper alignment and readjust as necessary as mentioned in **Step 3**.

3-1/2" OVAL BULL BAR
1999-2007 FORD SUPER DUTY F250-F550
2000-2006 EXCURSION

10. If not installing lights at this time, use the included (4) 6mm Button Head Bolts, (4) 6mm Lock Washers and (4) 6mm Flat Washers to plug the (4) threaded holes in the back of the cross bar, **(Figure 6)**.
11. If aftermarket lights, (not included), are to be installed, remove the rubber plugs on the top of the cross bar. Select (1) Light Bracket, **(Figure 7)**. Attach the light to the Light Bracket using the hardware included with the light. Attach the light and Bracket to the back of the Bull Bar with (2) 6mm Button Head Bolts, (2) 6mm Lock Washers and (2) 6mm Flat Washers, **(Figure 8)**. Adjust the light as desired.
NOTE: Depending on light design, repeated removal and reinstallation of the light and Bracket may be required for proper adjustment. Tighten all hardware.
12. Repeat **Step 9** to install the second light.
13. Do periodic inspections to the installation to make sure that all hardware is secure and tight.

To protect your investment, wax this product after installing. Regular waxing is recommended to add a protective layer over the finish. Do not use any type of polish or wax that may contain abrasives that could damage the finish.

For stainless steel: Aluminum polish may be used to polish small scratches and scuffs on the finish. Mild soap may be used also to clean the Bull Bar.

For gloss black finishes: Mild soap may be used to clean the Bull Bar.

Passenger Side Installation Pictured

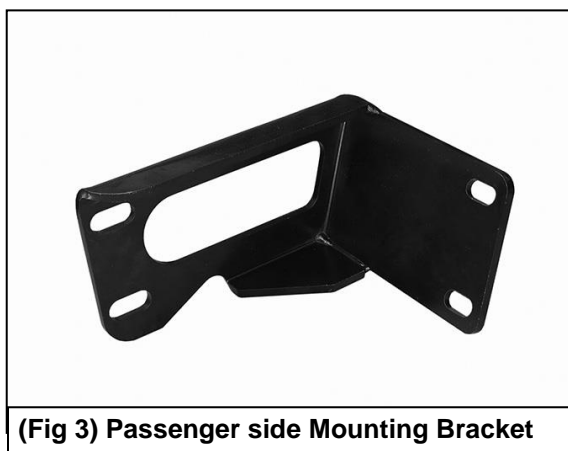
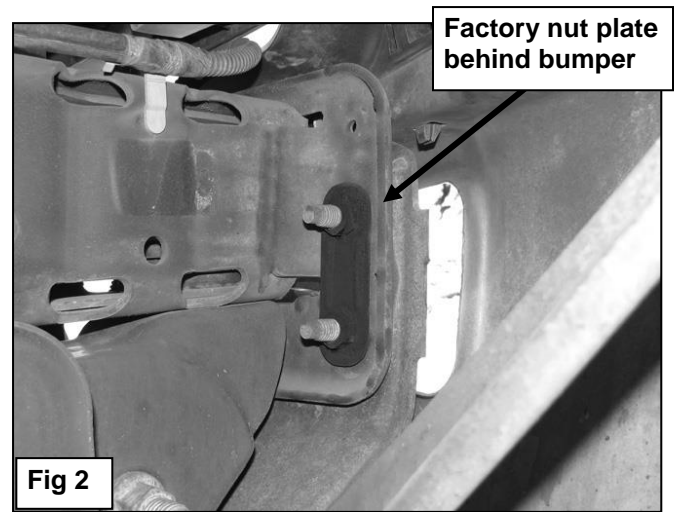
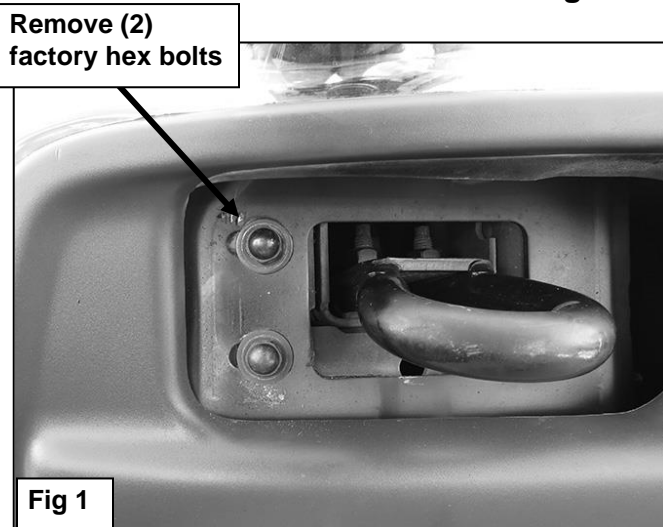

WARNING! Do not loosen or remove passenger and driver side bumper mounting bolts at the same time or bumper may move out of alignment or fall off of the vehicle. Only remove the bumper bolts from one side and install one Mounting Bracket at a time.

**3-1/2" OVAL BULL BAR
1999-2007 FORD SUPER DUTY F250-F550
2000-2006 EXCURSION**

Passenger Side Installation Pictured

Reuse factory bumper bolts and nut plate

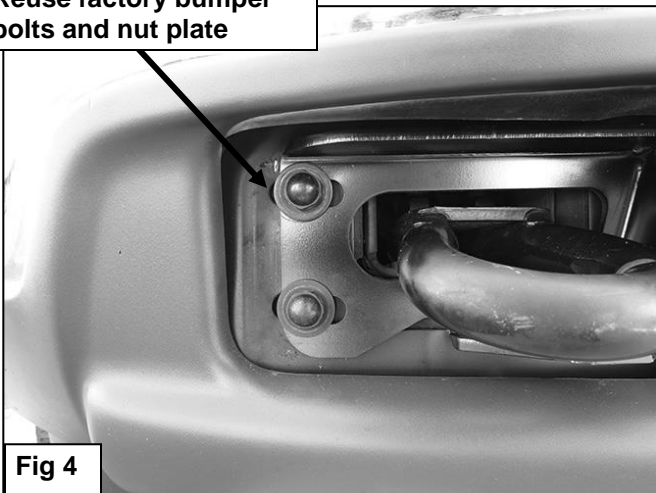

(2) 6mm Button Head Bolts
(2) 6mm Lock Washers
(2) 6mm Flat Washers

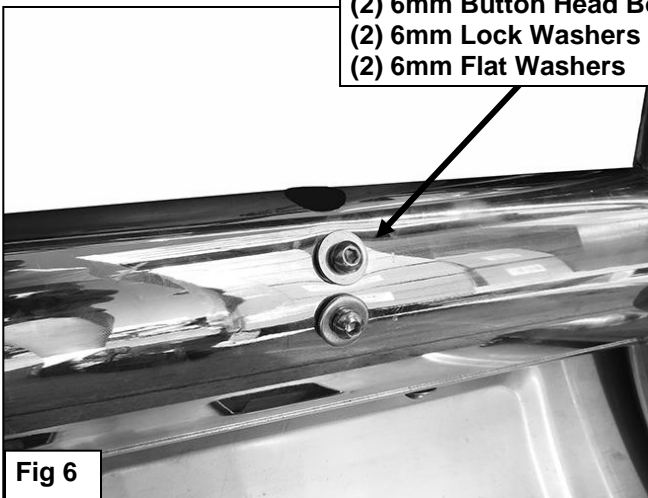

(2) 10mm Hex Bolts
(4) 10mm Flat Washers
(2) 10mm Lock Washers
(2) 10mm Hex Nuts

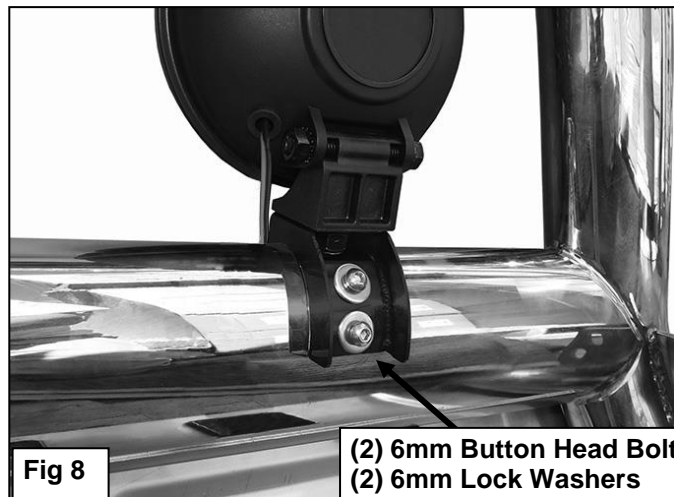

(2) 6mm Button Head Bolts
(2) 6mm Lock Washers
(2) 6mm Flat Washers
(light not included)

