

WARNINGS / LIMITATIONS

- Ensure that the hooks do not come in contact with the roof rail. (Risk of permanent deformation damage)
- Number of bicycles carried should not exceed designated carrying capacity for your specific model.
- 3 Bike maximum carrying capacity = 132lbs/60Kg.
- Check tightness of all bolts and knobs periodically.
- Check straps for wear and replace if worn.
- Not intended for off-road use.
- Not intended for tandems or recumbents.
- Do not install on a trailer or other towed vehicle.
- Failure to use blue safety strap may result in loss of bicycles.
- Do not open your trunk/rear hatch with the rack installed; it may cause damage to your vehicle.

IT IS YOUR RESPONSIBILITY TO INSURE THE SAFE AND PROPER USE OF THIS PRODUCT

Improper attachment or misuse of this product may be HAZARDOUS and may result in damage to your SR3141, bicycles, vehicle, or vehicles driving behind you as a result of colliding with or trying to avoid the fallen bicycles and SR3141. Some vehicles cannot safely accept any rear deck carrier. This bike rack has been conceived to protect the paint of the vehicle if properly mounted.

SAFE & PROPER USE OF YOUR TRUNK-MOUNTED BICYCLE CARRIER

Always secure your bicycle(s) to the bicycle carrier with the 80" strap. **DO NOT** let bicycle tires hang near the exhaust pipe. The hot exhaust could melt and destroy the tires. If a SR3141 mounting strap appears worn or frayed, **REPLACE IT. WORN STRAP ARE DANGEROUS. NEVER PLACE MORE THAN 3 BICYCLES** (Totalling 132lb/60Kg). Inspect and check you SR3141 before each use, both before and after placing bicycles on the SR3141, as the bicycles weight may cause the straps to loosen initially. Tighten all straps and hubs each time you inspect the carrier and bicycles. **CHECK** the tightness of all straps and adjustable hubs at regular intervals during use, more frequently on bumpy roads, and immediately if the bicycles shift position. Remove the SR3141 when not in use.



- Choose the illustration that most closely approximates the installation of the SR3141 on your vehicle.

3

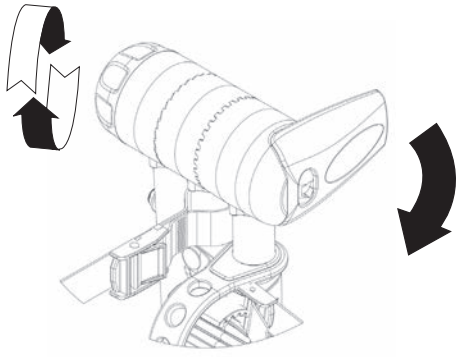

- Loosen the two adjustable hub assemblies by untightening the two knobs.

4

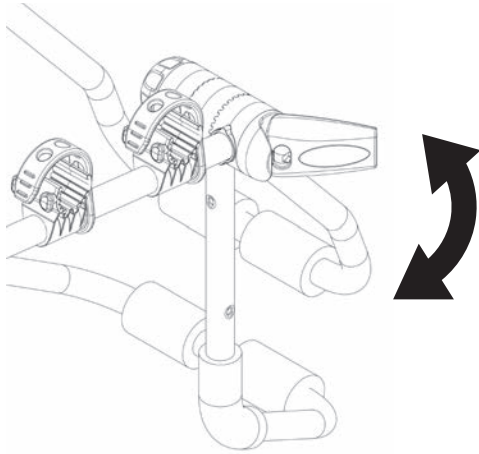

A

- Move the upper support leg until the SR3141 is set approximately to the same angle as in Step 2 that closely resembles your vehicle. Hold the SR3141 in place to check for correct adjustment. Only the upper support leg may rest on glass.

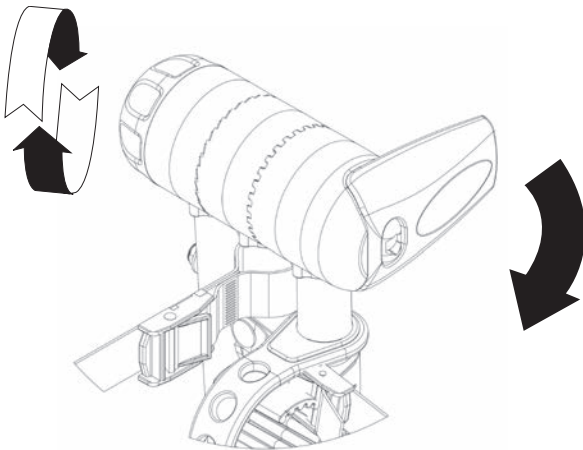

B

- Tighten the hubs by tightening the two knobs.

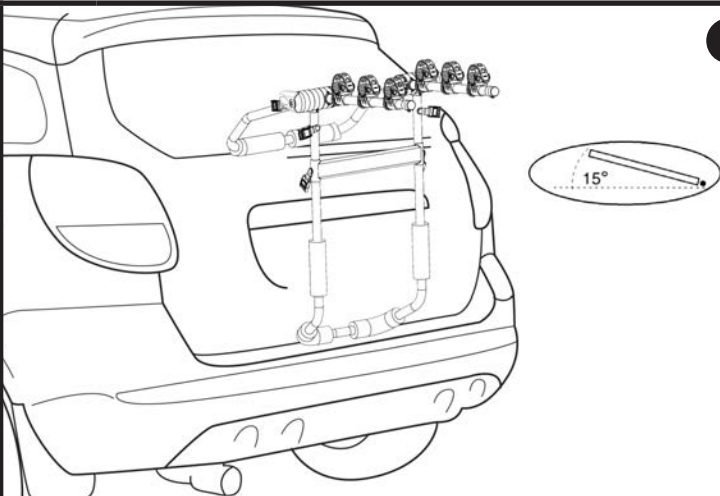

C

- The bike support arms should be angled slightly upward about 15°.

5

ATTACH UPPER HOOKS

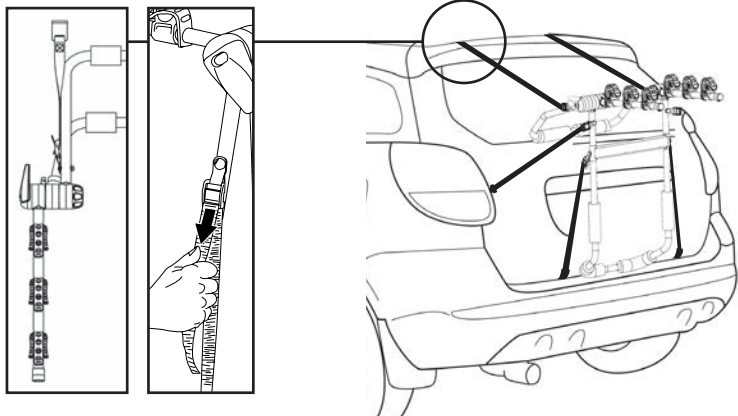

- Once you have the SR3141 assembled to its proper setting, place it on the vehicle. Now attach the two upper hooks into the slot at the leading edge of the trunk or hatch lid. Adjust the straps lengths so the SR3141 stays in place on the car in the desired position. The bike support arms should now be tilted slightly upward as Step 4.

CAUTION: Make sure that all the hooks are attached to metal, not fiberglass, plastic or glass.

6

ATTACH LATERAL HOOKS

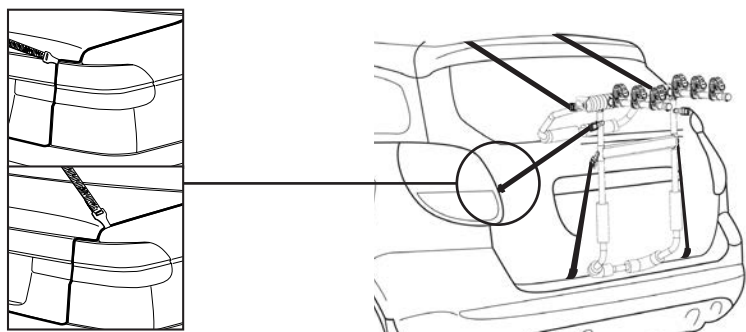

- Position the lateral hooks to the outside edge of the trunk lip, hatch lip or rear door lip. The hook location will be determined when the straps are under tension. The straps should always be at a 90° angle from the attached edge.

7

ATTACH LOWER HOOKS

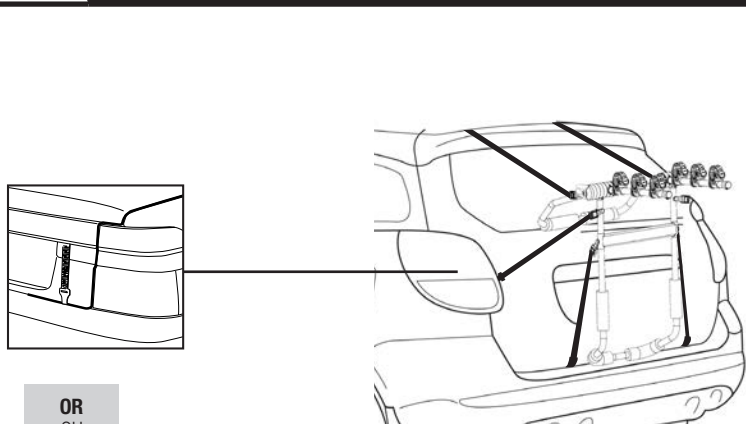

- Attach the two lower strap hooks, the preferred location is the bottom edge of the trunk/hatch. If this location is not working, try the underside of the bumper (if the bumper is secure enough), or metal frame members under the vehicle. Be sure that the strap is not rubbing against sharp objects that could cut the straps. **TIGHTEN ALL STRAPS.**

OR
OU
O

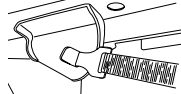

- Left and right tow hooks under the vehicle.

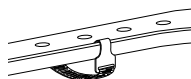
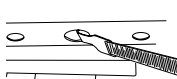

- Holes or edge of the metal bumper, behind the plastic bumper cover.

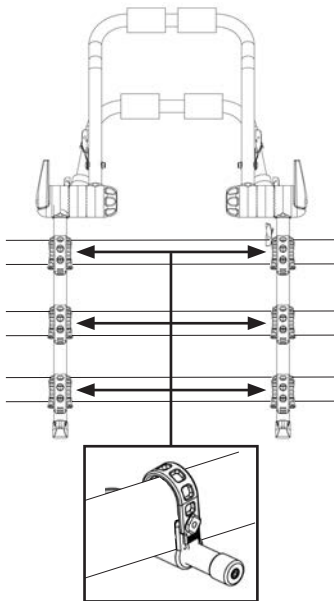

A

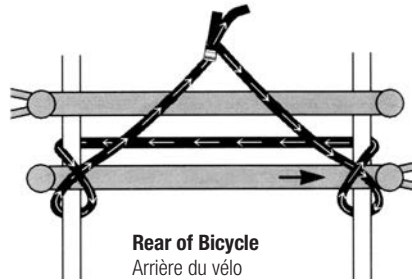

Rear of Bicycle
Arrière du vélo
Parte posterior del
vehículo

B

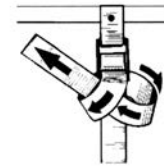

C

- Place the bicycle(s) onto the SR3141 support arms in the bicycle cradles. Make sure to cover the pedal closest to the vehicle to help prevent it from scratching the vehicle. Position or placement direction of the bicycles will vary according to the type of bicycle and size frame. Secure the bicycle(s) to the SR3141 support leg with the 80" strap.

- Making figure 8 shapes around the last bicycle frame and the SR3141 arms with the 80" strap (See illustration). We recommend to use extra shock cord or rope on the bicycles to prevent the wheels from turning and to prevent the frames from swaying into each other. Do not allow the bicycle tires to rest close to the exhaust pipe to prevent them from melting. **RE-TIGHTEN ALL STRAPS AND HUB ASSEMBLIES AS THE EXTRA LOAD OF PLACING THE BICYCLE(S) ON THE SR3141 MAY HAVE LOOSENED THE STRAPS.** Check the bicycle(s) and SR3141 at regular intervals during use, more frequently on bumpy roads, and immediately if the bicycle(s) shift position.

- For maximum security, we recommend that a simple knot be tied at the end of the buckle. The Trunk-mounted bicycle carrier should be removed when not in use to avoid additional wear on both the vehicle and the carrier.



Rear of Vehicle.