

IN-DASH DIN RADIO INSTALLATION KIT FOR SELECT 1995-UP HYUNDAI/MITSUBISHI VEHICLES

ILLUSTRATION 1

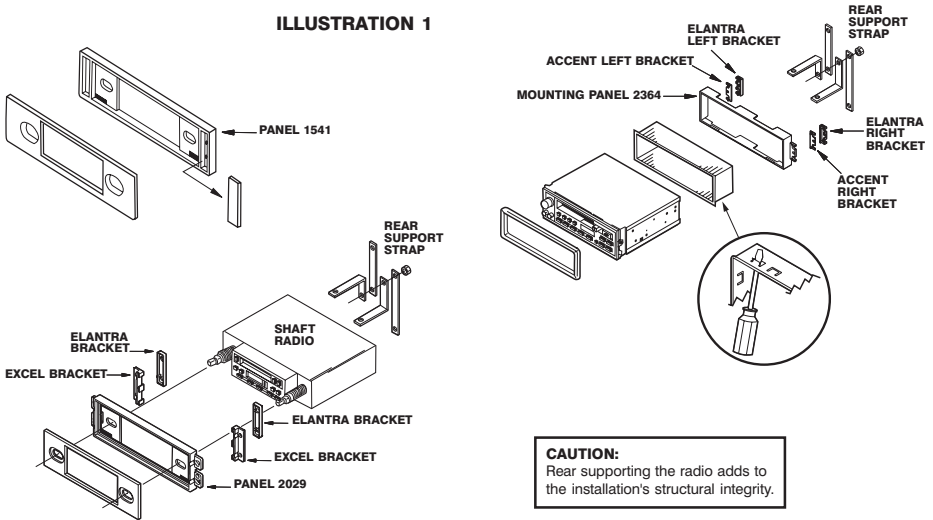

CAUTION:

Rear supporting the radio adds to the installation's structural integrity.

INTRODUCTION/PRELIMINARY

Thank you for purchasing the Scosche HY1601 Installation Kit. This installation kit was manufactured to the highest quality standards with the best materials available.

CAUTION:

Disconnect your vehicle's negative battery terminal before the installation to help prevent electrical damage. We recommend the use of a volt/ohm meter over a test light to check wiring. A test light or grounded wire probe can cause damage to the vehicle's computer and/or diagnostic systems. Avoid all factory air bag wiring - air bags can accidentally deploy causing serious injury or death.

NOTES:

- See your vehicle's instructions for any special tools your installation might require.
- Read all instructions accompanying your car stereo/cassette player for proper wiring and mounting instructions.

RADIO / KIT ASSEMBLY

SHAFT MOUNT RADIOS

Using the hardware supplied with the radio, secure the radio shafts to the mounting panel (kit) as shown in Illustration 1.

DIN RADIOS

Remove the sections indicated in Illustration 2. Use side cutters, an X-acto knife or hacksaw blade to cut the top and bottom sections (follow the cut lines) then simply pull outward to break off each tab.

REMOVING THE TABS

This kit features breakaway mounting tabs for all applications. Tabs that will not be used in a particular installation need to be cut off. Use the shaded brackets and tabs.

ILLUSTRATION 2

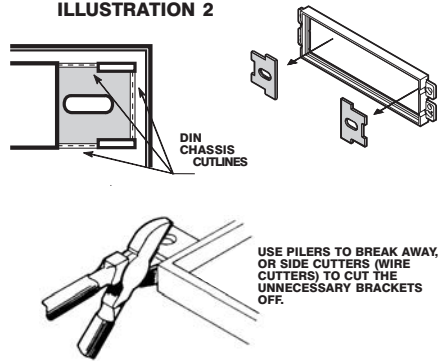

1995-99 Hyundai Accent



Read page 2 for kit assembly.

RADIO REMOVAL:

1. Extract (4) 10mm bolts from panel below steering column.
2. Remove ashtray and extract (2) screws from the ashtray cavity.
3. Open glovebox and use a panel removal tool to remove the glovebox stopper.
4. Extract (2) screws and remove entire glove box.
5. From behind glovebox area, unclip climate control cable.
6. Unclip (2) climate control cables from behind steering column panel on the side of duct/fan assembly.
7. Unsnap radio trim bezel, unplug and remove bezel.
8. Extract (4) screws holding radio in, unplug connectors, antenna, and remove radio.

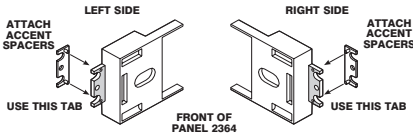

USE THE SHADED BRACKETS & THE INDICATED SPACERS.

1996-UP Hyundai Elantra



Read page 2 for kit assembly.

RADIO REMOVAL:

1. Carefully pop out shifter trim bezel and remove one screw at the bottom of the radio dash bezel.
2. Pop out dimmer control switch, unplug and remove.
3. Extract (1) screw from dimmer switch location.
4. From driver's side underdash area (above gas pedal) unhook temperature control cable.
5. Carefully pry out on radio dash bezel, to unplug, unplug all switches, vacuum lines and remove.
6. Extract (4) screws securing radio, unplug and remove.

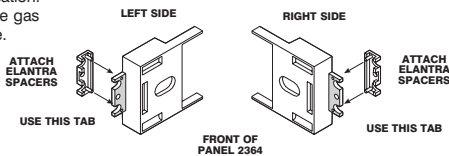

USE THE SHADED BRACKETS & THE INDICATED SPACERS.

1992-95 Hyundai Elantra



Read page 2 for kit assembly.

RADIO REMOVAL:

1. Remove the ashtray and extract the two screws from the inside.
2. Locate and remove the cover cap next to the steering wheel and extract the screw behind that is securing the radio dash bezel to the sub dash structure.
3. Carefully pull outward on the radio dash bezel releasing the clip on the top right corner. Disconnect all the connectors and remove.
4. Extract the four screws securing the radio to the sub dash structure. Disconnect all connectors and remove.

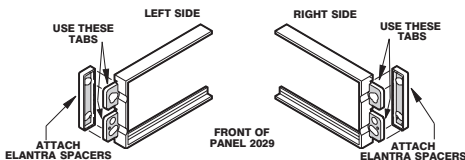

USE THE SHADED BRACKETS & THE INDICATED HOLE LOCATIONS. CUT OFF THE REMAINING BRACKETS AND DISCARD.

**1990-UP Hyundai Excel
1990-UP Mitsubishi Precis**



Read page 2 for kit assembly.

RADIO REMOVAL:

NOTE: The factory radio mounting unit is fastened to the trim panel. The chassis is inserted into a "pocket" in the cavity.

1. Remove the ashtray, then extract the two screws securing the trim panel at this location.
2. Pop out the two outside blank dummy switches located near the top of the trim panel, below the vents, then remove the single screw located behind each switch.
3. Pull the panel outward from along the bottom, then pull the panel down and away from the dash, disconnect the harnesses and remove the trim panel.
4. Remove the four screws securing the radio to the panel, disconnect the connectors and remove the radio.

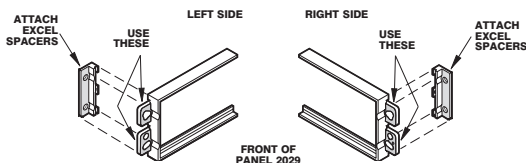
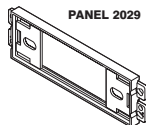

USE THE SHADED BRACKETS & THE INDICATED HOLE LOCATIONS. CUT OFF THE REMAINING BRACKETS AND DISCARD.

**1986-89 Hyundai Excel (All Models)
1987-89 Mitsubishi Precis (All Models)**



Read page 2 for kit assembly.

RADIO REMOVAL:

SHAFT-MOUNT RADIO REMOVAL:

1. Remove knobs from the radio.
2. Remove the shaft nuts and the radio face plate.
3. Remove (2) screws from each side of the radio.
4. Slide the radio out of the dash, disconnect wiring, and remove the radio.

DIN-TYPE RADIO REMOVAL

1. Place a small screwdriver into the slot on each side of the radio and pull the trim towards the rear of the car to release the trim snaps. Remove the trim and using the radio removal tools (available from the Hyundai dealer), slide the radio out of the cavity. Disconnect all wiring and remove the radio.
2. Extract the single screw from each side of the radio shroud (center screw of three).
3. Carefully pull on the edges of the radio/climate control trim panel to release snaps and remove panel.
4. Remove the (4) screws which secure the radio mounting shroud to the dash and remove the shroud.
5. Snap the radio/climate control trim panel back on to the dash (do not install the screws which hold the climate controls).

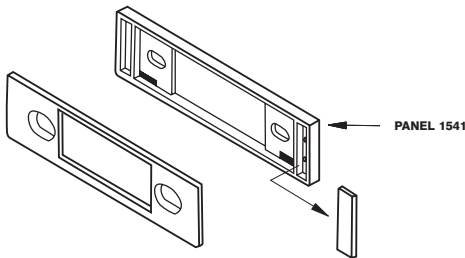

USE THE SHADED BRACKETS & THE INDICATED SPACER.

1991-UP Hyundai Scoupe



Read page 2 for kit assembly.

RADIO REMOVAL:

1. Remove the two sheet metal screws from the bottom of the radio trim bezel.
2. Carefully unsnap the trim bezel by prying outward with a panel removal tool. Unplug and remove all the connectors.
3. Extract the four sheet metal screws securing the radio to the dash. Unplug all the connectors and remove the radio.

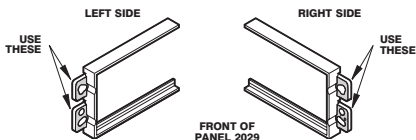
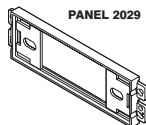

USE THE SHADED BRACKETS & THE INDICATED HOLE LOCATIONS. CUT OFF THE REMAINING BRACKETS AND DISCARD.

1995-UP Hyundai Sonata



Read page 2 for kit assembly.

RADIO REMOVAL:

1. Carefully pry up on the gear shifter trim bezel with a panel removal tool to release the clips and remove.
2. Extract the (1) screw at the bottom of the radio trim bezel.
3. Using a panel removal tool carefully pry out on the radio trim bezel to release the fastening clips, unplug all the connectors, and remove the bezel.
4. Extract the (6) screws securing the radio / pocket assembly to the dash, unplug all the connectors and remove.

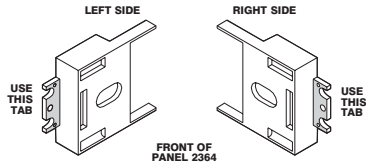
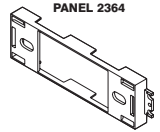

USE THE SHADED BRACKETS & THE INDICATED HOLE LOCATIONS.

1989-94 Hyundai Sonata



Read page 2 for kit assembly.

RADIO REMOVAL:

1. Extract the two screws from the inside walls of the dash pocket - one screw on each side.
2. Remove the plastic cover cap located at the top left side of the dash trim panel, extract the single screw from this location.
3. Release the trim panel, disconnect the connector from the defogger switch and remove the panel.
4. Extract the four screws securing the radio to the dash, pull the unit out of the cavity, disconnect the antenna cable/wire harness and remove the radio.

NOTE: Flip kit panel for this application so the brackets are at the front edge.

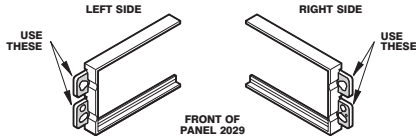
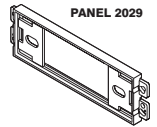

USE THE SHADED BRACKETS & THE INDICATED HOLE LOCATIONS.

1997-UP Hyundai Tiburon



Read page 2 for kit assembly.

RADIO REMOVAL:

1. Unscrew shift handle and remove.
2. Unsnap and remove shifter trim bezel.
3. For automatic, place car in Low, or for manual place shifter back in 4th gear.
4. Open ashtray, carefully pull back on Radio / console trim bezel to release, and disconnect lighter to remove.
5. Extract (4) screws securing radio, unplug and remove.

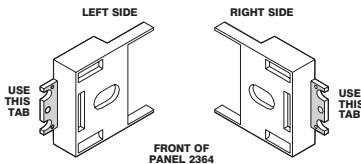
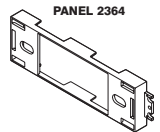

USE THE SHADED BRACKETS & THE INDICATED HOLE LOCATIONS.