



**ROCK HARD 4X4 JEEP WRANGLER JK 2/4-DOOR
2007-2018 OIL PAN, TRANSMISSION, CAT SKID PLATE
PART #: RH-6000-LA/RH-6003/6040/6043/6083/6080
Installation Manual**



Thank you for your purchase! Please read all instructions carefully prior to beginning installation of your Rock Hard 4x4 product.

PACKING LIST:

- 1 - SKID PLATE
- 1 - CATALYTIC CONVERTER
SKID PLATE (SHORT ARM
SKID ONLY)
- 1 - RIGHT SIDE FRONT STRAP
BRACE
- 1 - LEFT SIDE FRONT STRAP
BRACE
- 1 - SHIM
- 4 - 1/2" X 1 1/4" STD BOLTS
- 4 - 1/2" STD NYLOCK NUTS
- 3 - 12MM X 1.5 X 35MM BOLTS
- 1 - 12MM X 1.5 X 90MM BOLTS
- 1 - 12MM X 1.5 NUT
- 1 - 1/2" HARDENED FLAT
WASHER
- 1 - 1/2" LOCK WASHER
- 4 - 1/2" TAPERED WASHERS
- 2 - 3/8" X 1" BUTTON HEAD
BOLTS (SHORT ARM ONLY)
- 2 - 3/8" NYLOCK NUTS
(SHORT ARM ONLY)
- 1 - 3/8" X 1" HEX HEAD
- 1 - 3/8" LOCK WASHER
- 1 - 3/8" TAPERED WASHER

REQUIRED TOOLS:

- 18MM SOCKET
- 3/4" SOCKET
- PUNCH
- 9/16" WRENCH
- 7/32" ALLEN

Thank you for your purchase! Whether you bought this Rock Hard 4x4 product from one of our fantastic dealers or our factory direct team, we thank you for your business.

Rock Hard 4x4 is a family owned and operated business. We are headquartered in Saint Paul, Nebraska where we design, fabricate, and produce every single one of our products. Every single part we manufacture is 100% Made in the USA and exclusively in house by the Rock Hard 4x4 team.

We outsource zero processes.

To you, that means the product you are installing is the highest quality and longest lasting component on the market.

To us, that means you've selected a part we've spent years developing. Each Rock Hard 4x4 part has gone through more research and development and evolution than most people realize. While our parts may have the same striking look year after year, subtle revisions and refinements we implement maintain their status as the most durable and easy to install on the market.

TECH TIP: THIS SKID PLATE IS DESIGNED TO WORK WITH THE OEM CROSSMEMBER. WHILE MANY AFTERMARKET CROSS MEMBERS ARE COMPATIBLE, SOME MANUFACTURERS ARE USING DIFFERENT THREAD PITCHES. YOU MAY HAVE TO SOURCE YOUR OWN HARDWARE.

IF RETAINING OEM TRANSFER CASE SKID PLATE:

The factory Jeep transfer case skid plate has knurnled/stamped ends where it mounts to your crossmember. Because of this, you cannot install those 2 points between your Rock Hard 4x4 oil pan skid plate and crossmember. Those 2 Jeep transfer case skid mounts must be installed closest to ground.

1. Remove factory oil pan brace if your vehicle is equipped (2012 and newer JK's).

DO NOT remove OEM cross member.

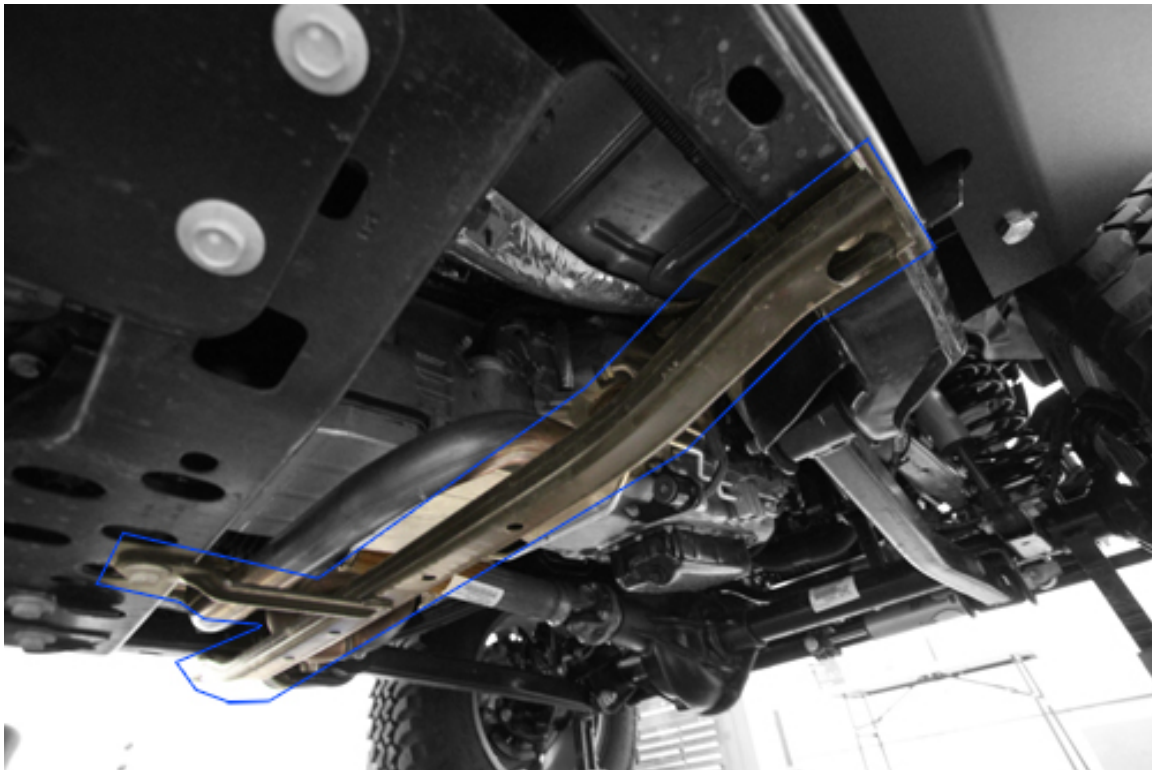

2. Remove factory transfer case skid plate using 18MM socket. *If not installing Rock Hard 4x4 Transfer Case Skid Plate at this time: Remember during reinstall it will install OVER Rock Hard 4x4 Oil Pan / Transmission skid plate. Over meaning it will be closest to ground. This is because of tapered front mounting holes on OEM transfer case skid plate. They cannot be installed under our skid plate as they will not allow it to sit flush against crossmember.*

LOCATE FRONT MOTOR MOUNT SUPPORT BRACKETS

3. Install passenger side mounting bracket (bend in each end forming an "s" shape.) Use two coarse thread $\frac{1}{2}$ " x $1\frac{1}{4}$ " bolts and two $\frac{1}{2}$ " nylock nuts. Upper bolts use front (toward front of vehicle) slotted hole in frame just below motor mount. Drop bolt from top down.

PRO TIP: On 2012 put bracket on outside of skid plate. This helps "shim over" the skid plate to clear the driveshaft boot on suspension systems with lots of articulation.

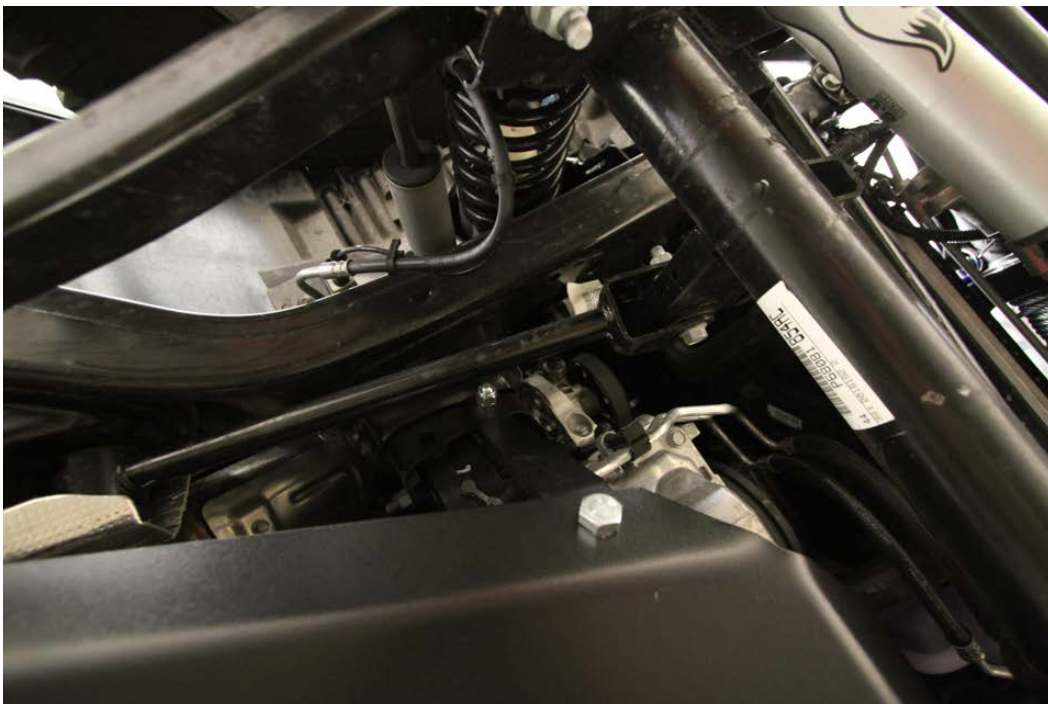

4. Install driver side bracket (bends in center). Use two coarse thread $\frac{1}{2}$ " x $1 \frac{1}{4}$ " bolts and nylock nuts. Short leg of bracket mounts to top and uses rear slotted hole in frame below motor mount. Hand tighten all bracket bolts. Drop bolt from top down.

PRO TIP: On 2012 put bracket on outside of skid plate. This helps "shim over" the skid plate to clear the driveshaft boot on suspension systems with lots of articulation.

5. Mount driver side bracket to front of skid plate. Hand tighten at this time.
6. Mount passenger side bracket to front of skid plate. Hand tighten at this time.
7. Install supplied shim plate if required to help clear exhaust crossover pipe. Shim plate will install against cross member, between cross member and oil pan skid plate (or if installing Rock Hard 4x4 Transfer Case skid plate at same time, the shim plate will install between cross member and transfer case skid plate, then install oil pan skid plate over the combo).
8. Tighten rear cross member bolts starting with outer driver side bolt first. Use a punch to help align plate if needed. Remember, if installing Rock Hard 4x4 Transfer Case at same time, the oil pan skid plate installs OVER the transfer case skid plate. That means the oil pan skid plate will install closest to ground. These can all be hand tight at this time.
9. Install outer most passenger side bolt with supplied longer bolt since there is no welded nut in that hole in cross member. Use bolt, rock dome washers, washer, lock washer,

and nut. This can be hand tight at this time. Install next 2 bolts.

10. Install catalytic converter skid plate (only if short arm skid plate – this is not included in long arm skid plate). Install remaining metric bolt using $\frac{3}{4}$ " socket into factory hole with welded nut into frame rail, driver side, near cross member. Hand tighten. Install 2 button head bolts with nylock nuts using $\frac{9}{16}$ " wrench and $\frac{7}{32}$ " allen. Once you've fully tightened 2 button head bolts, fully tighten frame rail bolt.
11. Tighten all hardware.
12. Start vehicle and let engine warm up and test drive. If you have aftermarket suspension that included an exhaust spacer, check to see if exhaust crossover pipe is contacting skid plates. If so, ensure you have installed shim plate. Ensure driver side exhaust hanger has not come dislodged. If contact is still made, contact Rock Hard 4x4 for an additional shim plate (sold separately).