

ROBINAIR®

Operating Manual

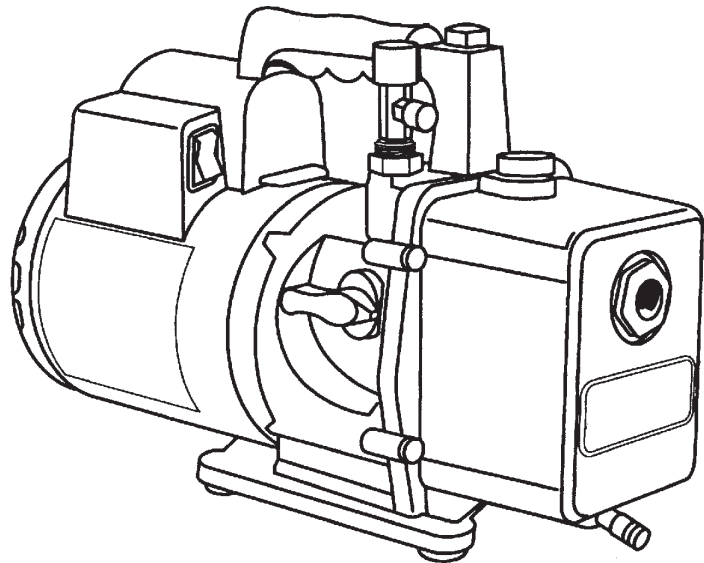

Model Nos. 15424 / 15448 / 15444
High Performance Vacuum Pump

Table of contents

.....

Warnings	2
Pump components.....	2
Robinair high performance vacuum pumps.....	3
Before using your vacuum pump.....	4
To use the gas ballast feature.....	5
To shut down your pump after use	5
To maintain your high vacuum pump.....	5
Vacuum pump oil	5
Oil change procedure	5
Cleaning your pump.....	5
Troubleshooting guide	6
Failure to start.....	6
Oil leakage.....	6
Failure to pull a good vacuum.....	6
Robinair pump specifications.....	6
Replacement parts	7
Warranty coverage	7
Out of warranty	7

For use on A/C-R systems using CFCs, HCFCs, and HFCs in conjunction with mineral oil, ester oil, alkylbenzene oil, and PAG oil as lubricants. Not for use with ammonia or lithium bromide systems. Not for use with flammable refrigerants.



Warnings



Wear safety goggles when working with refrigerants. Refrigerants can cause eye injury.



Incorrect use or connections may cause electrical shock hazards. Read and follow the instructions carefully and take precautions to avoid electrical shock hazards. All associated devices must be grounded before energizing circuits.



Normal operating temperature will cause certain external portions of the pump to be hot to the touch. Do not touch the pump housing or motor during operation.

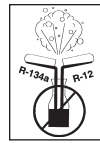

Use separate manifolds and hoses for R-134a systems. Cross-contamination with other refrigerant types will cause severe damage to the A/C system and to service tools and equipment. Do not mix refrigerant types through a system or in the same container!



Avoid breathing refrigerant and lubricant vapor or mist. Exposure may irritate eyes, nose, and throat.

To remove R-134a from the A/C system, use service equipment certified to meet the requirements of SAE J2210 (R-134a recycling equipment). If accidental system discharge occurs, ventilate work area before resuming service.

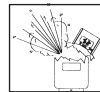

HFC-134a service equipment or vehicle A/C systems should not be pressure tested or leak tested with compressed air. Some mixtures of air/HFC-134a have been shown to be combustible at elevated pressures. These mixtures are potentially dangerous and may result in fire or explosion causing injury or property damage.

Additional health and safety information may be obtained from refrigerant and lubricant manufacturers.

Pump Components

Refer to graphic on next page.

1. Intake Fitting (upper fitting is 1/2" Acme; side fitting is 1/4" MFL)
2. Gas Ballast Valve (located beside handle base)
3. Oil Fill Port
4. Sight Glass
5. Die-Cast Aluminum Housing
6. Oil Drain
7. Molded Polycarbonate Base
8. Iso-Valve™ — isolates pump from system
9. High Torque Motor
10. Power Switch
11. Through-the-Handle Exhaust
12. Sure-Grip Handle

CoolTech® high performance vacuum pumps

Congratulations on purchasing one of Robinair's top quality CoolTech® vacuum pumps. Your pump has been engineered specifically for air conditioning and refrigeration service, and is built with Robinair's proven offset rotary vane for fast, thorough evacuation.

You'll appreciate these key features...

Iso-Valve™

Allows the pump to be shut off while still connected to the A/C-R system, which is handy for checking rate of rise. With the valve handle in the "Open" position, the pump is open to the system being evacuated. In the "Close" position, the pump is isolated from the system.

High vacuum rating

The two-stage, offset rotary vane design provides powerful, quiet high vacuum capability and assures moisture removal, while the high pumping capacity reduces evacuation time.

Multiple refrigerant capability

This pump can be used for R-12, R-22, R-500 and R-502, as well as for R-134a. The inlet "tee" has both 1/4" MFL and 1/2" Acme fittings to accommodate hoses from either type of manifold.

Directed exhaust

The exhaust is expelled through the handle to direct it away from the service technician.

Gas ballast

A precise amount of atmospheric air is introduced into the pump, preventing condensation of moisture vapor and helping maintain the purity of the pump oil. By using the gas ballast, the pump operates more efficiently and pump life is extended.

Sure-grip handle

The one-piece, molded handle makes it easy to carry the pump to and from job sites, and the handle stays cool to the touch during operation.

Compact design

Your pump measures approximately 40 cm long, while aluminum housing and offset rotary vanes keep the pump weight low, making it easy to carry.

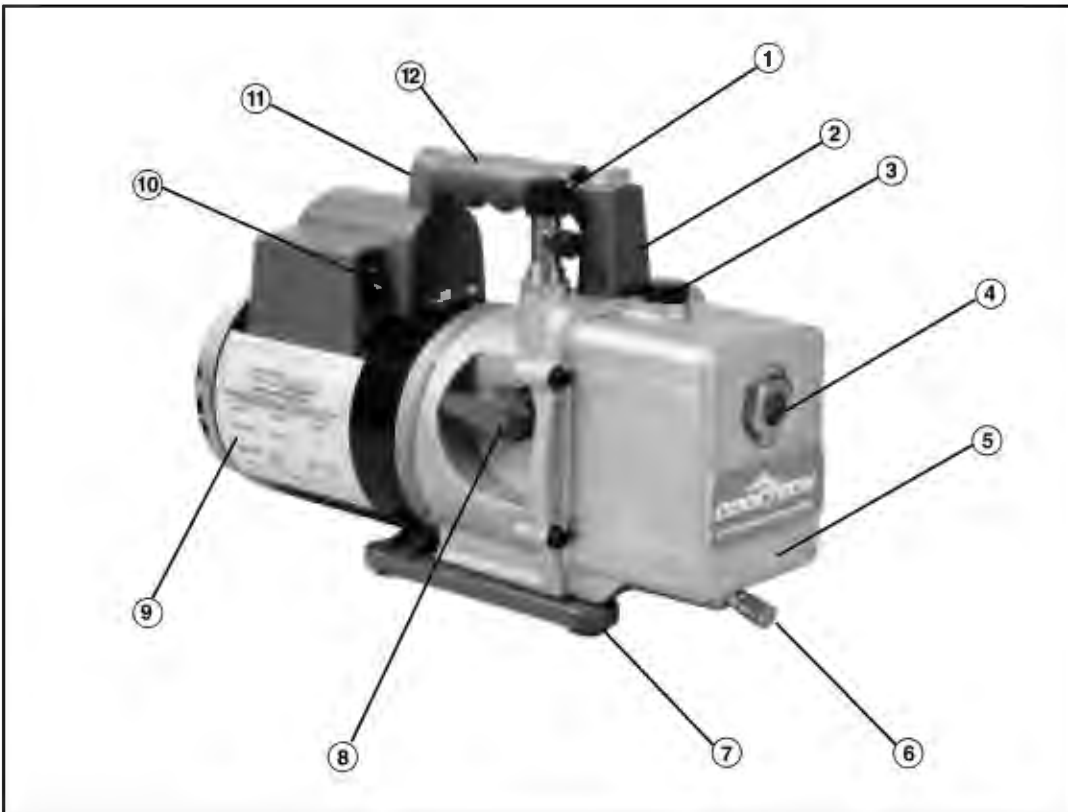

Before using your vacuum pump

In all cases, motors are designed for operating voltages plus or minus 10% of the normal rating (see SPECIFICATIONS). Single voltage motors are supplied fully connected and ready to operate.

1. Check to make certain the voltage and frequency at the outlet match the specifications on the pump motor decal. Check the ON-OFF switch to be sure it is in the OFF position before you plug the pump into an outlet. Check to be certain the gas ballast valve is closed. Remove and discard the exhaust plug from the end of the pump's handle.
2. The pump is shipped without oil in the reservoir. Before starting the pump, fill with oil. Remove the OIL FILL cap (black plastic plug directly in front of the handle) and add oil until oil just shows in the bottom of the sight glass. The approximate oil capacity of the pump is 400 milliliters.
3. Replace the OIL FILL cap and remove the cap from one of the inlet ports. Turn the Iso-Valve to OPEN. Turn the motor switch to ON. When the pump runs smoothly, turn the Iso-Valve to CLOSED and replace the cap on the inlet port. This may take from two to 30 seconds depending on the ambient temperature. After the pump runs for approximately one minute, check the sight glass for proper oil level — oil should be even with the sight glass OIL LEVEL line. Add oil if necessary.

NOTE: When the pump is running, the oil level should be even with the line on the sight glass. Underfilling will result in poor vacuum performance. Overfilling can result in oil blowing from the exhaust.

Your pump is now ready to evacuate air conditioning and refrigeration systems. Follow normal service procedures and the A/C-R manufacturer's instructions for connections to the system.

CAUTION

Before connecting your vacuum pump to an A/C-R system, remove refrigerant from the system in an accepted manner. Damage to the pump may occur if evacuation is started while the system is under high pressure. Robinair recommends use of our Refrigerant Recovery and Recycling equipment.

Wiring Instructions:

The CoolTech features dual voltage ranges. Before operating the pump, read and follow these rewiring instructions (if necessary) to be sure your pump is wired for the appropriate voltage.

CAUTION

Unplug the unit before beginning any service work. Improper use or connections can cause electrical shock. Only qualified personnel should perform service work.

The CoolTech vacuum pump is factory wired for a high voltage range of 220 to 240 volts. To wire the switch for a low voltage range of 110 volts to 115 volts, follow these steps.

1. Disconnect the unit from the AC power source before proceeding.
2. Loosen the screws on the plate at the rear of the motor, and carefully move the plate aside to clear the opening.
3. Disconnect the leads and reconnect for low voltage, following the diagram and chart. (High voltage connections are also shown if you want to rewire at some time.)
4. Check to see that all connections are secure and that there are no short circuits. Be sure the grounding connector is properly connected.
5. Re-install the plate on the rear of motor with the screws which were loosened in Step 2.

IMPORTANT: Check for short circuits using a continuity tester before reconnecting to the AC power source.

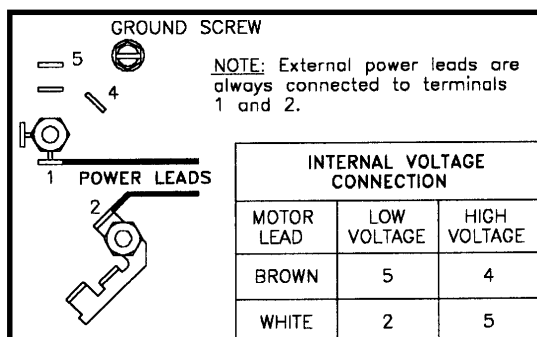

General Electric Motors

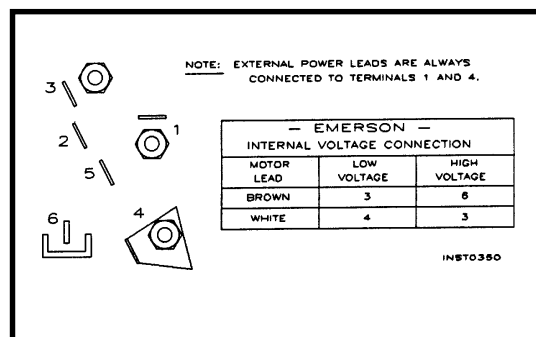

Emerson Motors

To use the gas ballast feature

Moisture from the A/C-R system that is carried into the pump as a vapor tends to condense into a liquid and combine with the vacuum pump oil. When moisture contaminates the pump oil, it reduces the pump's ability to reach its ultimate deep vacuum level.

The gas ballast valve purges a small amount of atmospheric air through the exhaust chamber. This extra volume of air mixes with the vapor from the refrigerant system to prevent condensation and to help exhaust moisture in the form of vapor from the pump.

To use the gas ballast, start the pump and open the gas ballast valve until the system has reached approximately 1000–3000 microns.

Close the valve to allow the pump to pull down to its ultimate vacuum level. The gas ballast valve is located beside the handle, opposite the inlet fitting.

The gas ballast valve may be opened or closed at any time during pump operation. It is fully open at two turns counterclockwise.

NOTE: *Robinair recommends the use of a thermistor vacuum gauge to most accurately measure vacuum levels.*

To shut down your pump after use

To help prolong pump life and promote easy starting, follow these procedures for shutdown:

1. Close the manifold valve between the pump and the system.
2. Turn the Iso-Valve to the CLOSED position.
3. Remove the hose from the pump inlet.
4. Turn the pump power switch to OFF, then return the Iso-Valve to the OPEN position for a few seconds to relieve any vacuum inside the pump.
5. Cap the inlet port to prevent any contamination or loose particles from entering the port.

To maintain your high vacuum pump

For maximum performance, Robinair recommends changing vacuum pump oil after each use.

Vacuum pump oil

The condition and type of oil used in any high vacuum pump are extremely important in determining the ultimate attainable vacuum. Robinair recommends the use of our Premium High Vacuum Pump Oil. This oil has been specifically blended to maintain maximum viscosity at normal running temperatures and to improve cold weather starts.

Robinair Premium High Vacuum Pump Oil is available in handy quart containers or in convenient gallon containers. Order by part number:
13203 — Quart (shipped 12 quarts per case)
13204 — Gallon (shipped 4 gallons per case)

Oil change procedure

1. Be sure the pump is warmed up.
2. Remove the OIL DRAIN cap. Drain contaminated oil into a suitable container and dispose of properly. Oil can be forced from the pump by opening the inlet and partially blocking the exhaust with a cloth while the pump is running. Do not operate the pump for more than 20 seconds using this method.
3. When the flow of oil has stopped, tilt the pump forward to drain residual oil.
4. Replace the OIL DRAIN cap. Remove the OIL FILL cap and fill the reservoir with new vacuum pump oil until the oil just shows at the bottom of the sight glass. The approximate oil capacity of the pump is 400 milliliters.
5. Be sure the inlet ports are capped, then turn ON the pump. Allow it to run for one minute, then check the oil level. If the oil is below the sight glass OIL LEVEL line, add oil slowly (with the pump running) until the oil reaches the OIL LEVEL line. Replace the OIL FILL cap, making sure the inlet is capped and the drain cap is tight.
6. If the oil is badly contaminated with sludge that forms when water is allowed to collect in the oil, you may need to remove the oil reservoir cover and wipe it out.

Repeat this procedure as required until the contamination is removed. Replace the OIL DRAIN cap and refill the reservoir to the proper level with fresh pump oil (see Step 4).

Cleaning your pump

Clean the pump with soap and water only. Do not use commercial cleaners that contain degreasing agents that can damage polycarbonates. The pump handle and base are made of Lexan*, one of the toughest polycarbonate plastics available. However, it is sensitive to degreasing agents.

**Lexan is a registered trademark of General Electric*

Motor Lubrication

After three years of normal service or one year of heavy-duty service, add oil annually. Use electric motor oil or SAE 10 oil.

Troubleshooting guide

Your CoolTech® pump has been designed for dependable use and long life. If something should go wrong, however, the following guide will help you get the pump back into service as quickly as possible.

If disassembly of the pump is required, please check your warranty. The warranty may be voided by misuse or customer tampering which results in the pump being inoperable.

Failure to start

Check the line voltage. Robinair pumps are designed to start at $\pm 10\%$ line voltage (loaded) at 0°C. At extremes, however, switching between the start and run windings may occur. When starting the pump in cold temperatures, be sure the Iso-Valve and inlet port are open to free air.

Oil leakage

1. Be sure the oil is not a residual accumulation from spillage, etc.
2. If leakage exists, the module cover gasket or the shaft seal may need replacing. Follow the instructions supplied with the seal replacement kit, part number 15367. If leakage exists in the area of the drain plug, you may need to reseal the plug using a commercial pipe thread sealer.

Failure to pull a good vacuum

1. Be sure the Iso-Valve on the pump is in the OPEN position and the gas ballast knob is tightly sealed.
2. Be sure the vacuum gauge and all connections are in good condition and leak-free. You can confirm leakage by monitoring the vacuum with a thermistor gauge while applying vacuum pump oil at connections or suspected leak points. The vacuum will improve briefly while the oil is sealing the leak.
3. Be sure the pump oil is clean. A badly contaminated pump may require several oil flushes. See OIL CHANGE PROCEDURE.

NOTE: Use only high vacuum pump oil. Other oils will prevent pull-down to a deep vacuum.

4. Check to be sure the gas ballast knob is tightly closed.
5. Be sure the oil is at the proper level. For maximum pump operation, the oil must be even with the OIL LEVEL line on the sight glass when the pump is running. See OIL CHANGE PROCEDURE. Do not overfill — operating temperatures will cause the oil to expand so it will appear at a higher level than when the pump is not running. To check the oil level, start the pump with the inlet capped. Check the oil level in the sight glass. Add oil if necessary.

CoolTech® pump specifications

Model 15424/15448/15444

Frequency Range	50–60 Hz
Free Air Displacement	4 cfm
	94 l/m @50 Hz
	113 l/m @60 Hz
Stages	2
Motor Speed	1425 rpm @50 Hz
	1725 rpm @60 Hz
Voltage Range	110–115V
	220–250V
Factory Micron Rating	20 microns
Approximate Oil Capacity	400 ml
Weight	14.5 kg
Width	14.3 cm
Height	24.8 cm
Length	40 cm
Intake	1/4" MFL and 1/2" Acme
Min. Starting Temp. (at 90% Voltage)	0°C
Motor Size	1/3 HP
	Capacitor Start
Operating Temp.	68°C

NOTE:

1. All motors are internally protected (automatic reset).
2. Operating temperatures are typical for normal operating conditions.
3. Model 15448 has a bipolar side grounded plug.
4. Model 15444 has an Australian plug type AS3112.

U.S. Patents 4,523,897; 5,209,653. Other U.S. and Foreign Patents Pending.

Because of ongoing product improvements, we reserve the right to change design, specifications, or materials without notice.

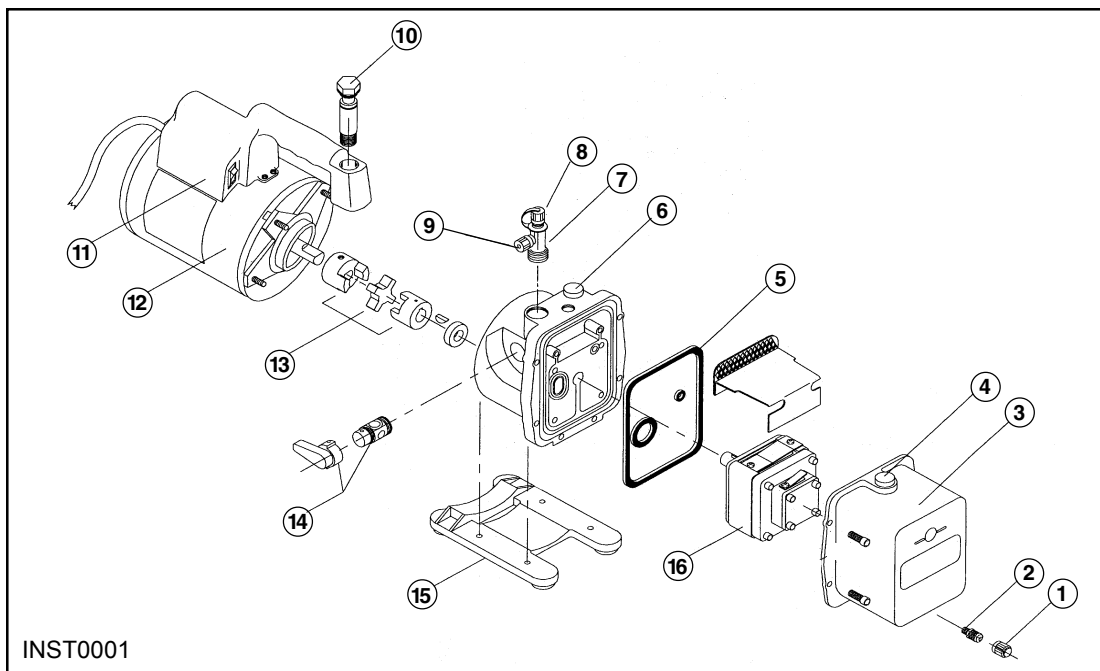

INST0001

Replacement parts

Part	Figure	Order
Oil Drain Cap (qty. 6)	1	40572
Oil Drain Kit (includes cap and drain)	2	48116
Module Cover Kit (includes items 1, 2, 4, 5)	3	15337
Oil Fill Cap (includes item 6)	4	15371
Intake "Tee" Fitting (includes caps)	7	15495
Intake Cap (Acme)	8	15330
Intake Cap (1/4" flare - qty. 6)	9	41139
Vent Bolt (includes O-rings)	10	15338
Power Cord and Switch Assembly	11	15366
Motor	12	15665
Coupling	13	48103
Iso-Valve™ Assembly	14	15368
Base and Foot Assembly	15	15369
Replacement Module (includes items 1–9 & 14)	16	15547
Seal Replacement Kit	(not shown)	15367

Warranty coverage

Robinair CoolTech® vacuum pumps are warranted against defects in material and workmanship for one year of normal use from the date of purchase. See your distributor for warranty details.

Out of warranty

A pump which is no longer covered by the one-year warranty period and which fails to operate properly should be returned to the distributor with a full written explanation of the problem. The distributor may suggest returning the pump to the factory. Before returning an out-of-warranty pump, review all maintenance procedures to avoid an unnecessary return. Replacement parts are available for doing your own service.

NOTICE: Airborne Noise Emissions

This equipment has been tested for airborne noise emission per the Council Directive for Machinery (89/392/EEC) Section 1.7.4 Instructions — Essential Health and Safety Requirements.

Sound levels do not exceed 80dB(A) actual value.