



# RHINO-RACK

## Rhino 2500 series for Euro Crossbar.

**Important:** Please refer to your fitting instruction to ensure that the roof racks are installed in the correct locations. Check the contents of kit before commencing fitment and report any discrepancies. Place these instructions in the vehicle's glove box after installation is complete.

**IMPORTANT Care Instruction: Wash and clean the vehicle roof prior to fitting the Roof racks. PLEASE READ THROUGH INSTRUCTIONS BEFORE FITTING.**

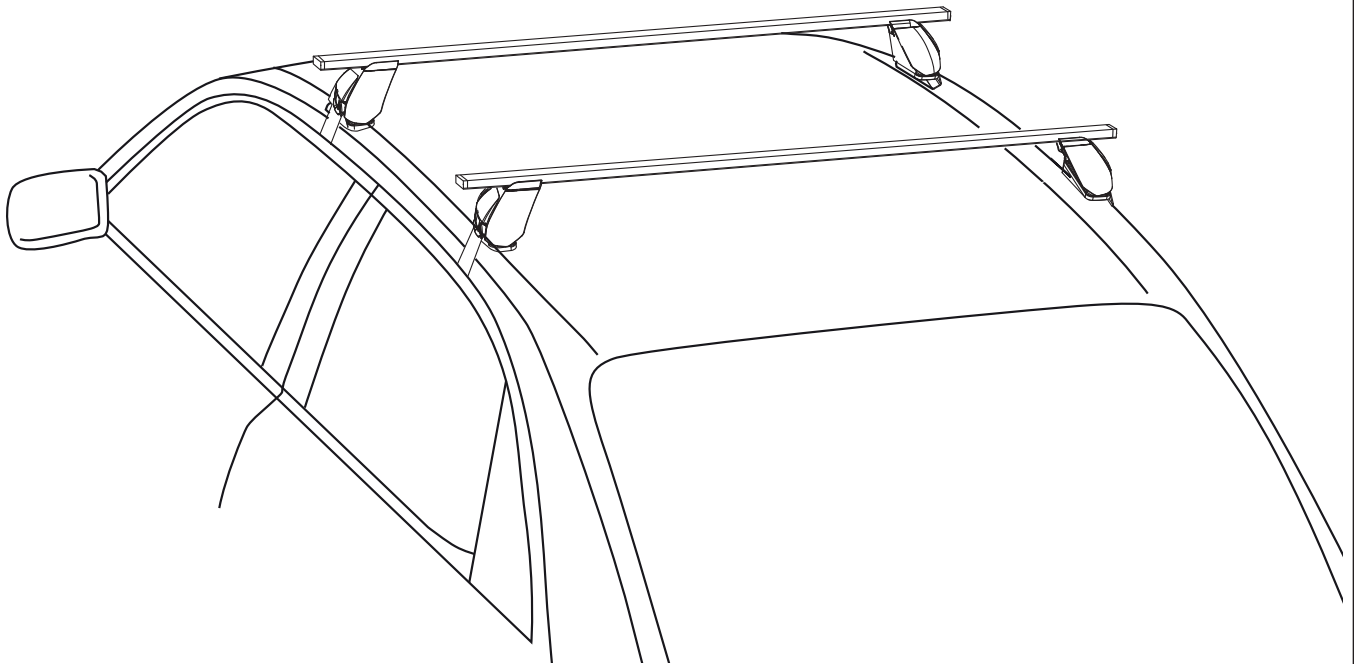

**Maximum carrying capacity: 75kg (165lbs) evenly distributed over crossbars. Please refer to your vehicle manufacturers handbook and DK Specification sheet for maximum roof loading. Always use the lower of the two figures.**

### **Recommendations:**

It is essential that all bolt connections be checked after driving a short distance when you first install your crossbars. Bolt connections should be checked again at regular intervals (probably once a week is enough, depending on road conditions, usage, loads and distances travelled). You should also check the crossbars each time they are refitted. Make sure to fasten your load securely. Please ensure that all loads are evenly distributed and that the centre of gravity is kept as low as possible.

**Use only non-stretch fastening ropes or straps.**

### **Load Ratings**

When these roof racks are to be used on a vehicle that is driven off sealed roads, the manufacturer maximum roof load rating (to be found in the vehicles User Manual) should be **halved**. For example, if the vehicles maximum roof load rating is 70kgs (subtract 5kg = weight of crossbar and legs), these racks, when fitted to this vehicle should have no more than 35kgs loaded on them

### **Caution:**

The handling characteristics of the vehicle changes when you transport a load on the roof. For safety reasons we recommend you exercise extreme care when transporting wind-resistant loads. Special consideration must be taken into account when cornering and braking. **Please remove crossbars when putting vehicle through an automatic car wash.**



# Rhino 2500 series for Euro Crossbar.

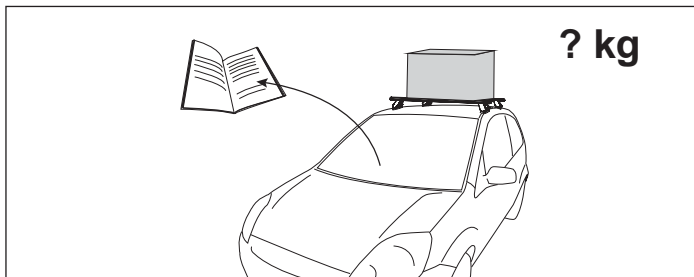
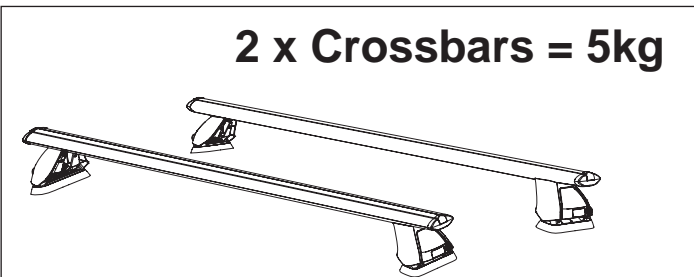
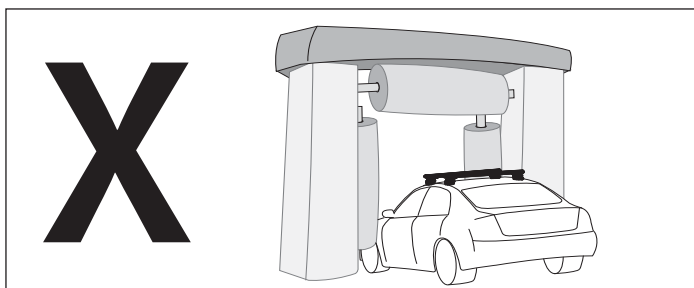
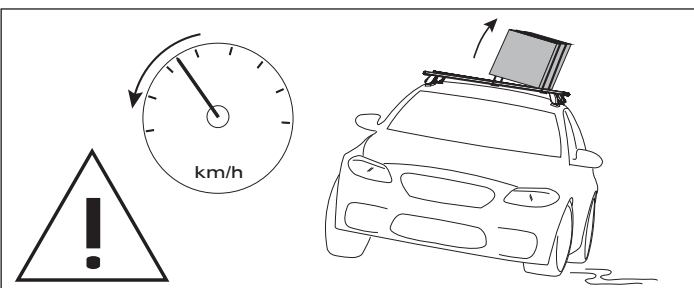
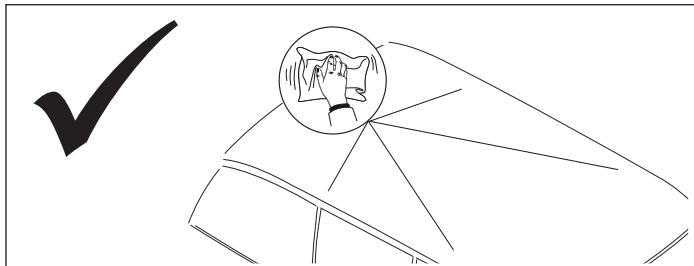
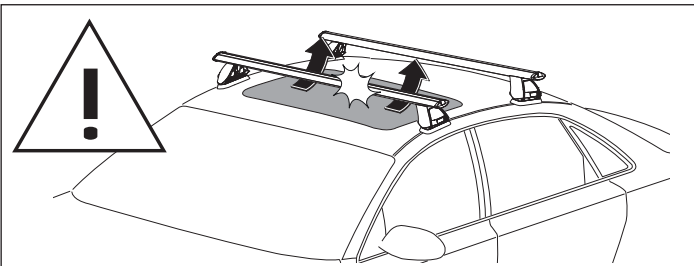
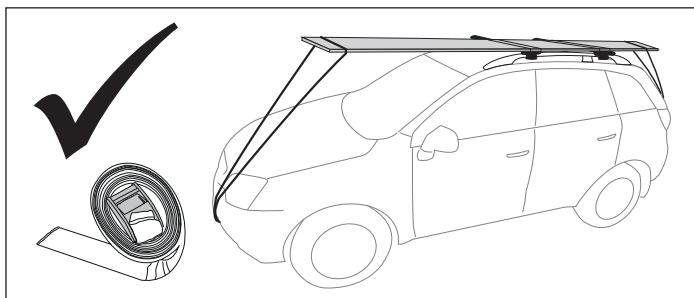
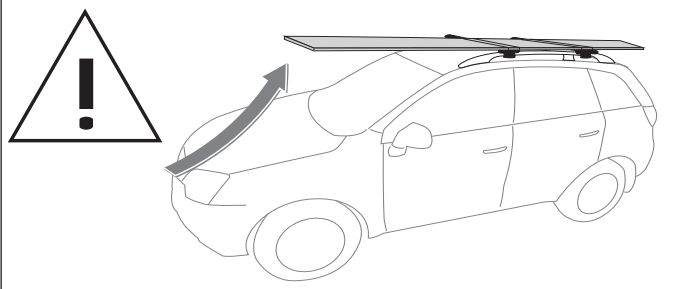

When these roof racks are to be used on a vehicle that is driven off sealed roads, the manufacturer maximum roof load rating (to be found in the vehicles User Manual) should be **halved**. Do not forget to subtract 5kg from your maximum carrying capacity due to the weight of the crossbars and legs.

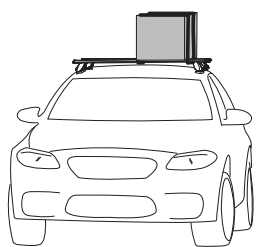

**70kg load rating** (Urban road) = **35 kg load rating** (Off road - 70kg / 2)

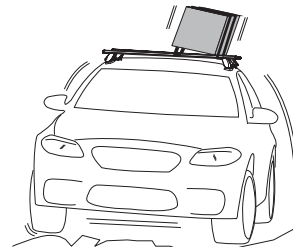

## WARNING! Important Load Carrying Instructions

With utility vehicles, the cabin and the canopy move independently. Roof racks and vehicle can be damaged if the item transported is rigidly fixed at points on both the cabin and canopy. Instead, rigidly fix to either the cabin roof racks or the canopy roof racks.

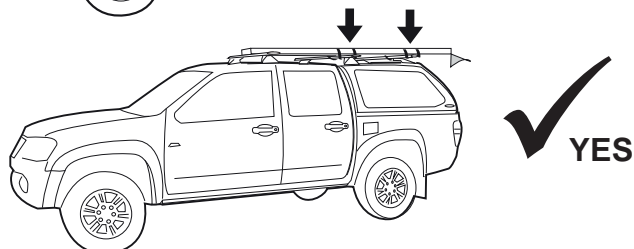
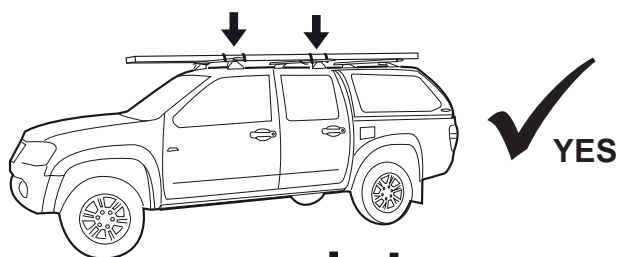
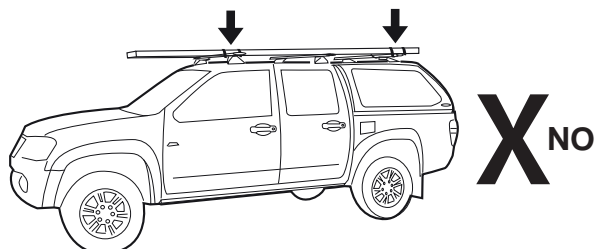



# Rhino 2500 series for Euro Crossbar.

Item	Component Name	Qty
1	Euro End Cap	4
2	Euro Crossbar	2
3	Front Cover	4
4	Key	2
5	M8 Clamp Bolt	4
6	Clamp	4
7	Rubber Base Pad	4
8	Foot Plate	4
9	Leg	4
10	Euro Crossbar Adaptor	1
11	M6 x 25mm Security Screw	4
12	M6 Spring Washer	4
13	M6 Flat Washer	4
14	M6 Square Nut	4
15	Allen Key - Long	1
16	Leg Position Labels	4
17	Fitting Instructions	1

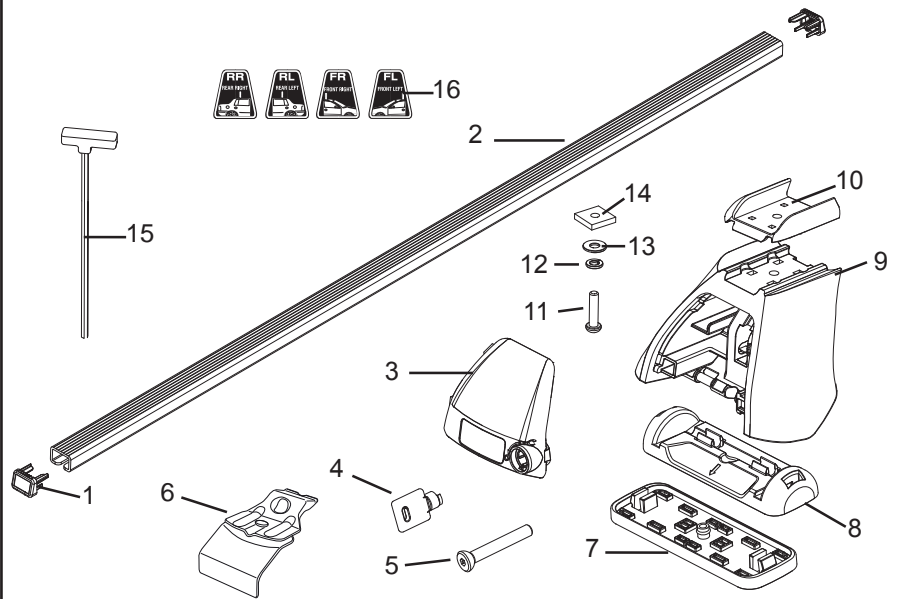
**Tools Required;**

Security key (inc. in kit) Side Cutters/Scissors, Tape Measure, Rubber Mallet.

**NOTE : ALL MEASUREMENTS AND FITMENTS SHOWN APPLY FOR THE EURO CROSSBAR.**

**NOTE: Refer to the DK Specification sheet for correct placement (Front or Rear, Left or Right) of the FOOT PLATE, RUBBER PAD and METAL STRAP. Also refer for sizes to cut the BAR MEASUREMENT STRIP.**

**1** Insert the euro crossbar adaptor (4) legs into the leg square holes and snap the adaptor in place.

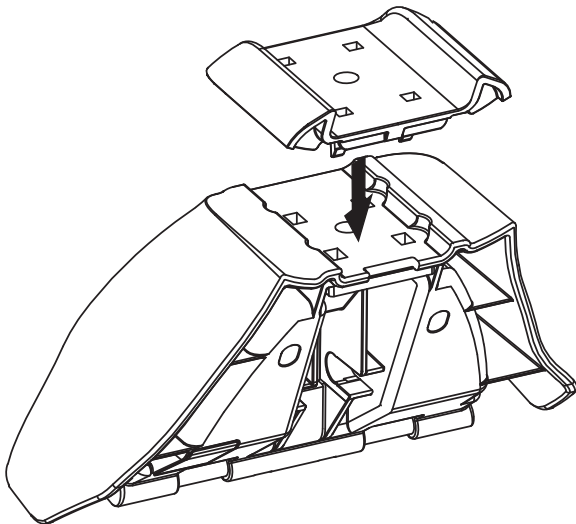

**2** Fasten the M6 x 25mm screw, flat and spring washer assembly to the M6 Square nut as shown. Leave loose at this stage.

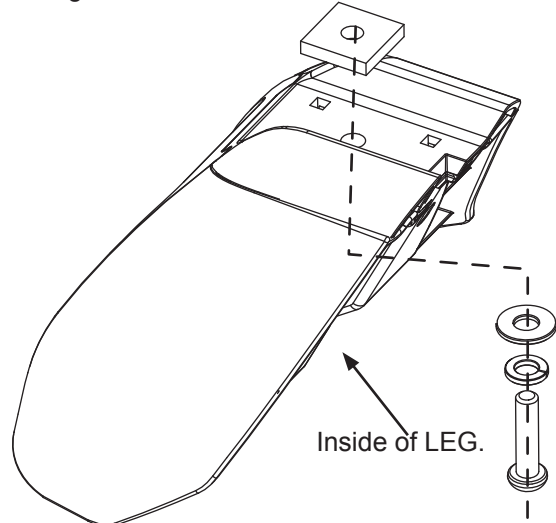

**3** Clip the rubber pad onto the foot pad, ensure the center tube is fully located in the foot plate and the ends are clipped in.

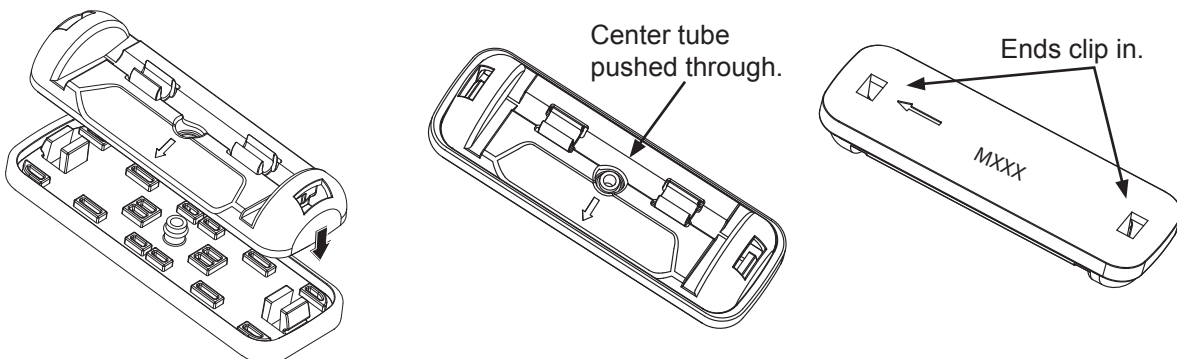



## Rhino 2500 series for Euro Crossbar.

- 4** Clip the foot plate onto the leg with the arrow facing in the correct direction **IN or Out** according to your vehicle listed in the DK specification sheet. Diagram shows arrow facing OUT).

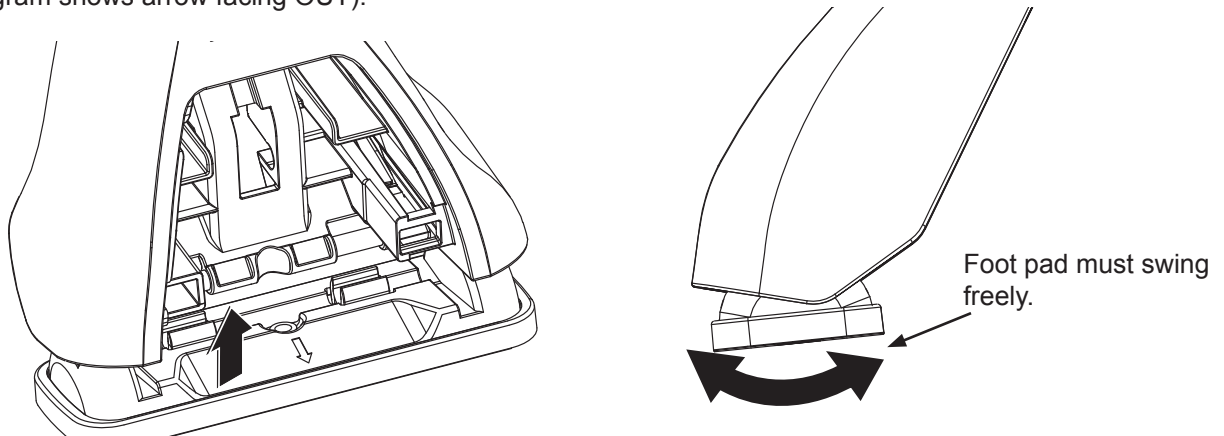

- 5** If the nut is removed, insert the pivot nut into the back of the leg. Ensure the nut snaps in place. **Note:** large portion of the nut to face the rear of the leg.

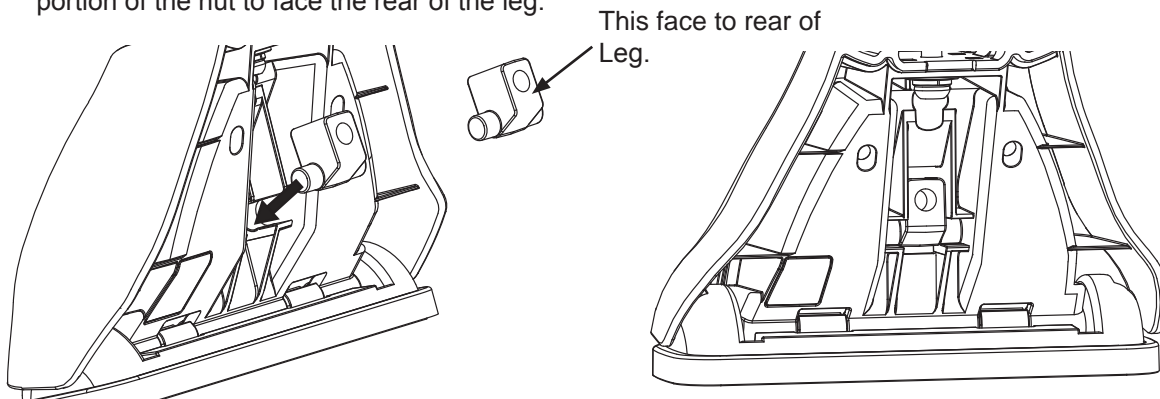

- 6** Insert the M8 clamp bolt through the clamp and from the front of the leg, screw the bolt into the pivot nut. **DO NOT TIGHTEN AT THIS STAGE.**

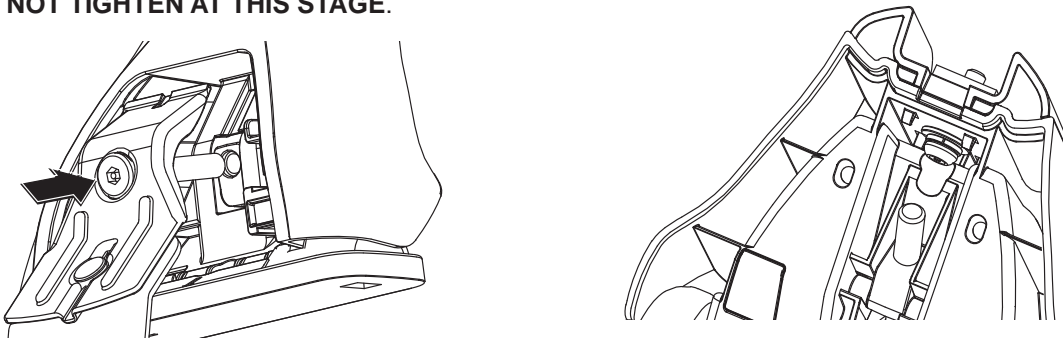

- 7** Turn the crossbar over and clip the bar measuring strip into the cut out, ensure the end of the strip locates against the end of the cut out. Slide assembled leg into the cut out until it butts up against the end of the Bar measurement strip.

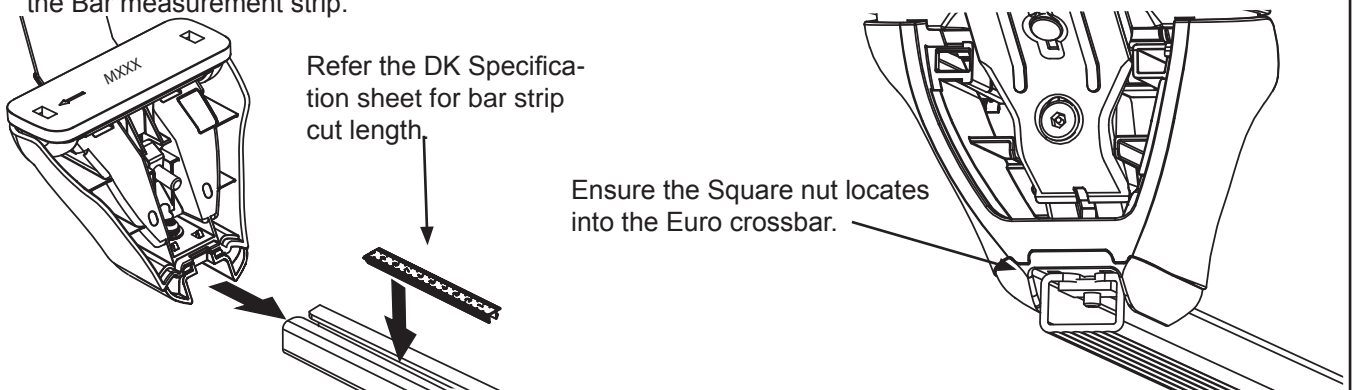



## Rhino 2500 series for Euro Crossbar.

8

Tighten the leg security screw to **3-4N/m** with the allen key provided.  
**DO NOT OVERTIGHTEN .**

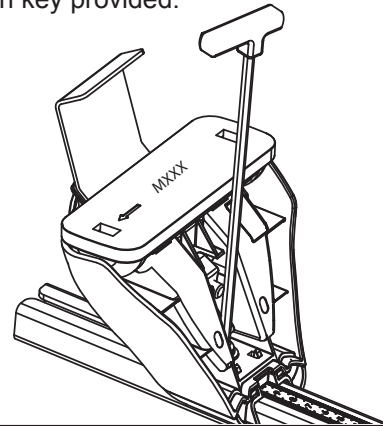

9

Press the endcaps onto the ends of the crossbars, a rubber mallet may be needed to gently tap the end caps on.

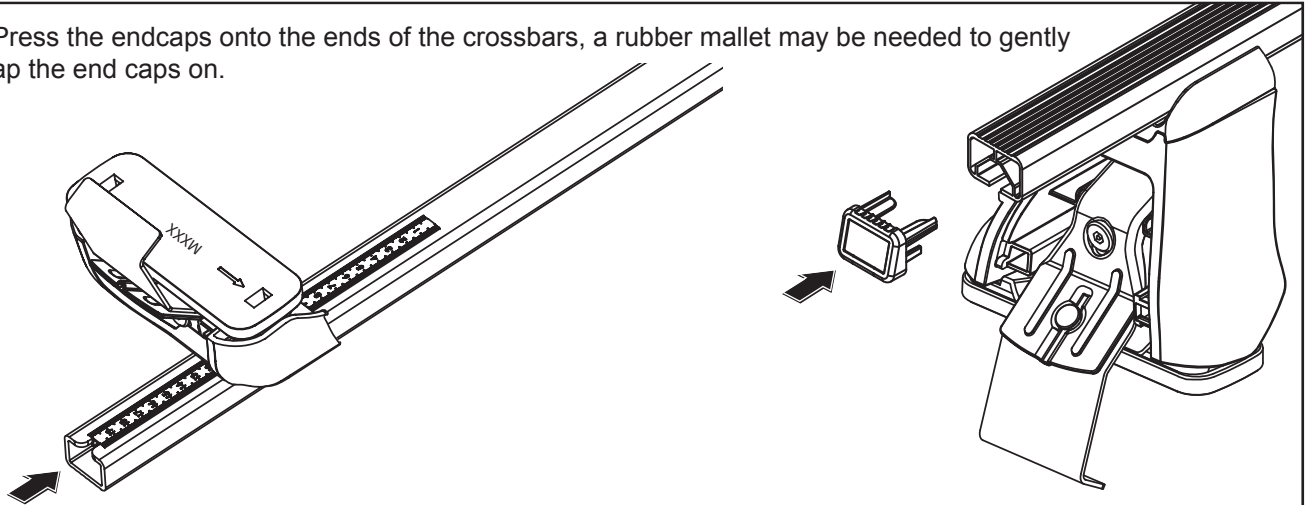

10

Stick the leg position labels inside the leg. The labels identify the position of the leg on the vehicle roof and are used as a guide when refitting the crossbars after removal. Refer layout below.

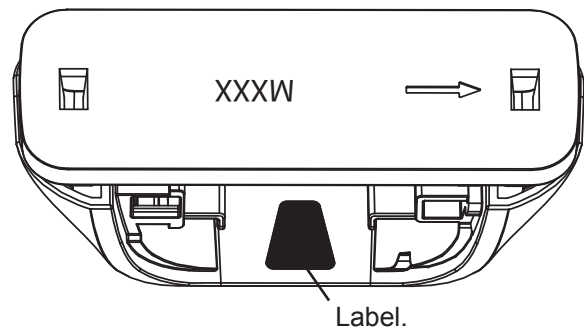
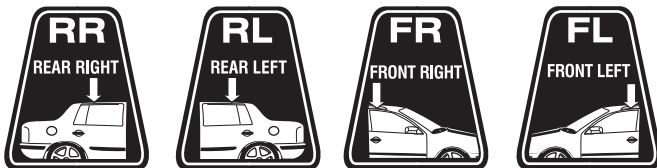

Label.

11

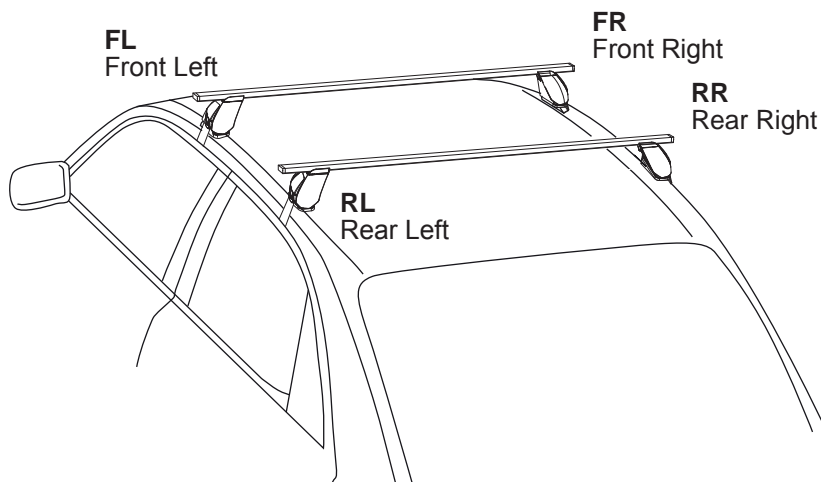

Note: The front and rear leg positioning labels provided are stuck onto the legs to identify front and rear crossbar positions when refitting the racks.



## Rhino 2500 series for Euro Crossbar.

- 12** Wipe the roof clean before placing the assembled roof racks on. Open the doors and hook the metal strap in at the top of the door jam underneath any rubber seals that may be there. **TIGHTEN THE BOLTS ON EACH SIDE OF THE VEHICLE EVENLY, DO NOT TIGHTEN ONE SIDE AT A TIME. TIGHTEN TO 4-5N/M. DO NOT OVER TIGHTEN.**

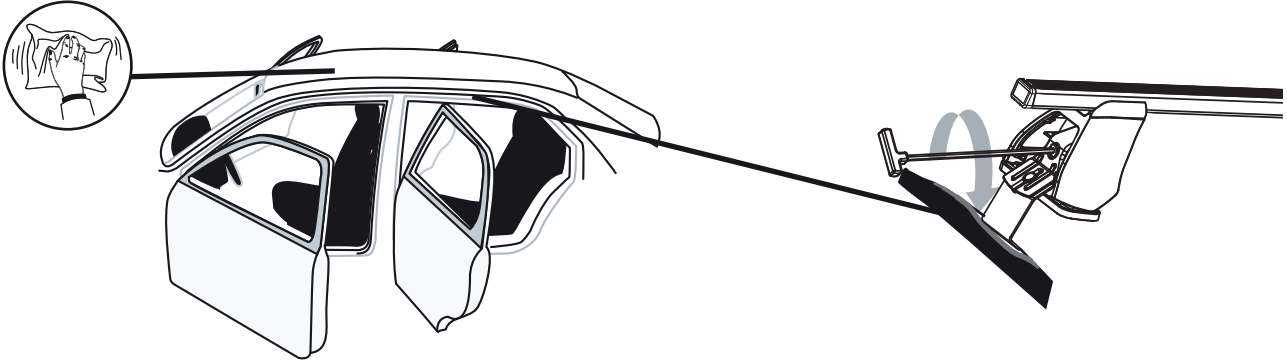

- 13** Insert the two lugs on the side of the front cover into the leg, using the key provided turn the lock barrel to the open position (O), engage the locking tab into the leg and turn to lock. Refer instruction 14 below for lock positions.

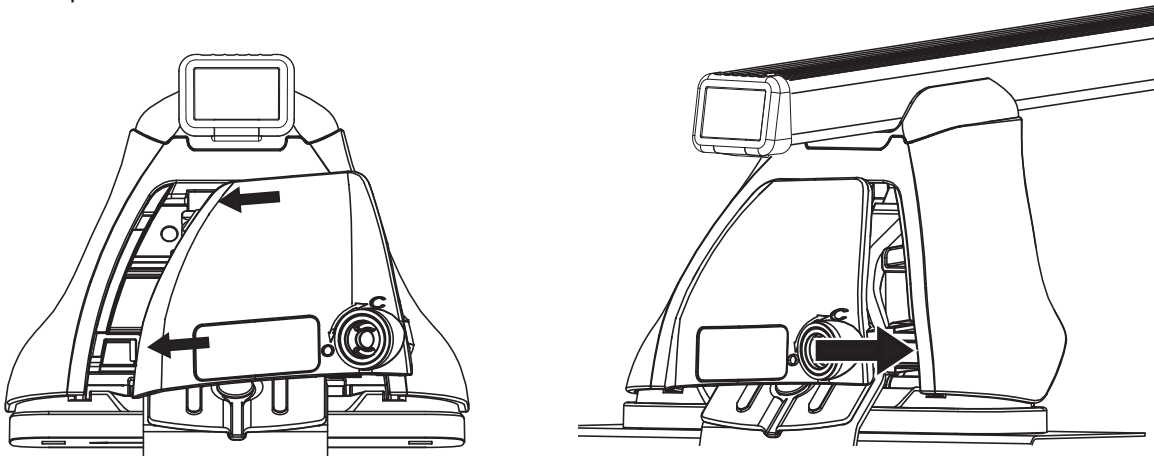

**14**

