

Voltage Drop: Solving the Root Causes of Charging System Failures

Repeat charging system failures are most often traced to vehicle concerns. A voltage drop in the power or ground circuits of an alternator can cause premature failure and is often the source of misdiagnosis. To prevent early failures or reduced charging system voltage, you should always perform voltage drop tests as part of a charging system diagnosis. In this issue, we'll provide you the necessary information to accurately measure charging system voltage drop.

What is voltage drop?

In every operating circuit there is voltage used by each component, connection and wire. Figure 1 below shows a simple lamp circuit and normal voltage drops. Compare those readings to the ones in Figure 2 where the bulb is dimly lit. Excessive voltage is being used in the ground circuit to overcome the resistance, preventing the bulb from lighting up as brightly.

Figure 1

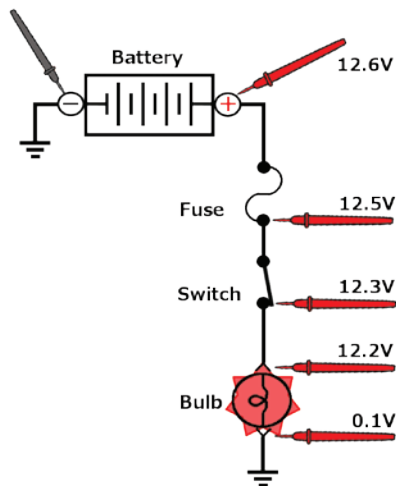
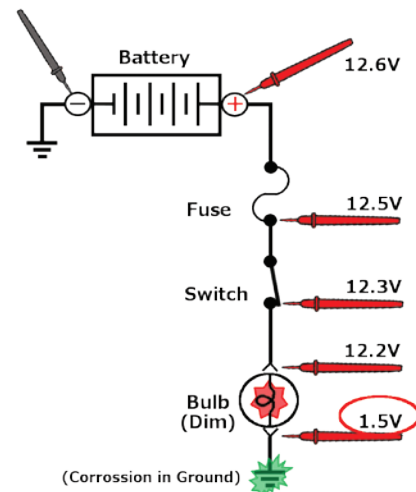

Figure 2



Voltage drop in the charging system can cause multiple symptoms, depending upon the location of the voltage drop:

- Undercharge or overcharge
- Failed battery as a result of under/overcharge
- Repeat alternator replacement or misdiagnosis
- Other vehicle electrical issues

Performing a Voltage Drop Test

While these tests are most accurate with the aid of a carbon pile, we'll review how to perform these tests using the vehicle as the load.

Note: There must be current flow for voltage drop to occur. For this reason you cannot perform this voltage drop test on a vehicle with a failed charging system. Make the necessary repairs to the charging system before conducting this voltage drop test.

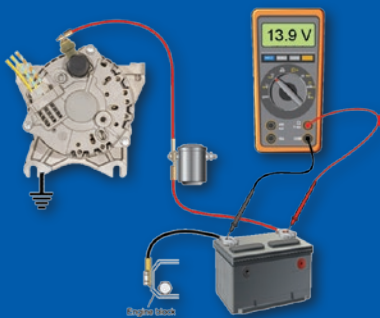

STEP 1

Be sure to maintain Step 1 conditions during all remaining test steps.

Start the engine and hold at about 2000 RPM. Turn on all possible electrical loads:

- Headlamps on high beam
- Blower motor on high speed
- Wipers on high speed
- Any other accessories that require electrical power

STEP 2

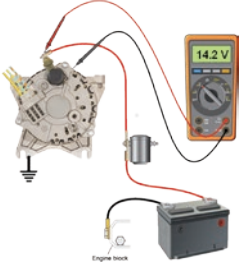

Measure the voltage at the alternator by placing the black lead of the voltmeter on the case of the alternator and the red lead of the voltmeter on the alternator B+.

- If the reading is 12.6 volts or less, repair the charging system and repeat this test.
- If reading is greater than 12.6 volts, record the reading and proceed to Step 3.

STEP 3

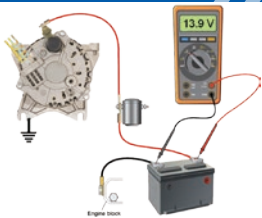

Measure the voltage at the battery by placing the black lead of the voltmeter on the negative battery terminal and the red lead of the voltmeter on the positive battery terminal.

- If the reading is within 0.5 volts of the Step 2 results, the charging system power and ground are within specifications. Proceed to Step 6.
- If the reading is more than 0.5 volts from the Step 2 results, then proceed to Step 4 to isolate the failed circuit.

STEP 4



Measure positive circuit voltage drop by placing the black lead of the voltmeter on the positive battery terminal and the red lead of the voltmeter on the alternator B+ post.

- If the reading is less than 0.03 volts, verify the alternator is charging and retest.
- If the reading is between 0.03 and 0.40 volts, the positive circuit is within specification and you can proceed to Step 5.
- If the reading is greater than 0.40 volts, inspect and repair the positive circuit from the battery to the B+ post of the alternator. Be sure to closely inspect for corrosion, loose connections or failing fusible links.

STEP 5



Measure negative circuit voltage drop by placing the black lead of the voltmeter on the housing of the alternator and the red lead of the voltmeter on the negative battery terminal.

- If the reading is less than 0.03 volts, verify the alternator is charging and retest.
- If the reading is between 0.03 and 0.40 volts, the negative circuit is within specification and you can proceed to Step 6.
- If the reading is greater than 0.40 volts, inspect and repair the negative circuit from the battery to the alternator housing. Remember to closely inspect for corrosion, loose connections, and that the alternator brackets are both securely mounted and corrosion-free.

STEP 6



If the vehicle you are working on has a voltage sense line, verify sense voltage drop as well. If you are uncertain about the vehicle you are working on, consult the wiring diagram or contact Remy technical support. Place the black lead of the voltmeter on the case of the alternator and back probe the sense line with the red lead of the voltmeter.

- If the reading is within 0.3 volts of the Step 2 results, the sense line is within specification.
- If the reading is greater than 0.3 volts of the Step 2 results, then inspect and repair the sense line back to the source voltage.

The example picture is specific for Ford vehicles. Sense line location varies by manufacturer.