



Silverado LD/HD Curved Light Bar Roof Bracket Kit 2150

07-13 Chevy Silverado LD/HD 50" Curved Light Bar Roof Bracket Installation Instructions

This kit also works for: 07-13 Sierra LD/HD and 06-14 Tahoe/Suburban/Yukon/Yukon XL/Escalade

KIT CONTENTS:	
Description	Qty.
Light Bar Driver Side Bracket	1
Light Bar Passenger Side Bracket	1
96" 16AWG Red Wire	1
16AWG Butt Splice	2
Black Rubber Grommet	2
1/4" Hex Nut	1
#10 Flat Washer	2
#10-32 x 1" Hardened Steel Bolt	1
SS #10-32 5/8" Pan Head Screw	4
#10-32 x 0.585" Steel Rivet Nut	4
Zip Tie	10

Tools Needed:

- 7mm, 10mm Sockets
- T15 Torx Bit
- Flat Head Screw Driver
- Center Punch
- 1/8", 1/4", 19/64", 3/4" High Quality Hardened Drill Bits
- 7/16" Wrench
- 1/8", 5/32" Hex Bit
- Electrical Tape
- Marker
- Thread Locker
- RTV Silicone

Recommend installing 10050W Wind Noise Canceling Molding on 50" Light Bar before installing

Mounting Bracket Installation

1. Remove bracket kit from packaging. Check to see if all parts from above kit contents table are included.
2. Remove driver and passenger pillar trim, from inside cab, by removing **7mm** headed bolt and pulling straight out. If pillar trim has handle, use **10mm** socket to remove two bolts before pulling trim off.
3. Remove driver and passenger assist handle from inside cab (**If equipped in vehicle**)
4. Remove driver and passenger sun visor from headliner inside cab. Use **T15** torx bit to remove 3 bolts on each.
5. Place piece of scrap metal or plastic in roof liner against passenger and driver door to make sure drill bit doesn't pierce through side curtain airbags.
6. With driver and passenger door open; pull down upper rubber door seal.

7. Place tape where bracket will be mounted and mark drill holes with a marker. See **Figure 1** for bracket mounting location.
8. Center punch each hole, drill **19/64"** hole for rivet nuts to be inserted into. If holes are bigger than **19/64"**, the rivet nut will not install correctly. (**Recommend using new high quality hardened drill bits and starting with a 1/8" bit followed by a 1/4" bit and finally a 19/64" drill bit to drill holes**)
9. Place a #10 flat washer, hex nut, another #10 flat washer and rivet nut on black hardened steel bolt, shown in **Figure 2**, and place in drilled hole. Use a **7/16"** wrench to hold nut and **5/32"** hex bit to turn the hardened steel bolt until rivet nut is tightened down. (**Do not install with drill, use hand tools only**). Remove hardened steel bolt, flat washers and hex nut. Repeat in all four holes.
10. Mount brackets with pan head screws. Use **1/8"** hex bit to tighten down screws. (**Recommend sealing rivet nut areas up with RTV Silicone and using thread locker for bracket screws**)
11. Mount 50" light bar between brackets. Refer to light bar instruction for installation.

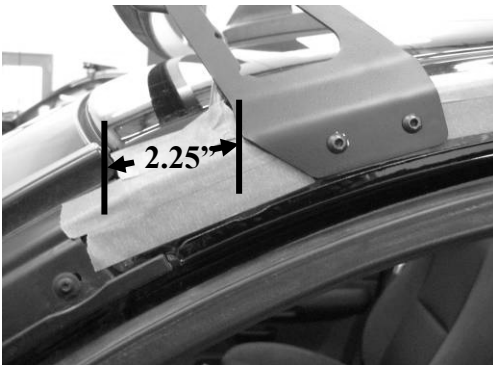

Figure 1

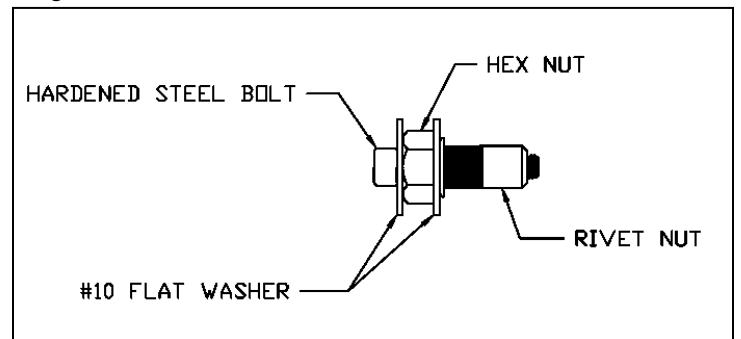

Figure 2

Wiring Installation

1. Drill **3/8"** hole through fire wall; verify that opposite side of fire wall is clear of obstructions. Insert grommet into hole.
2. On the wiring harness, remove black plastic sleeve covering the red and black power wires between the relay and the fuse holder
3. Cut red power cable behind fuse holder, be sure to leave enough wire to wire this piece back into the harness
4. Insert the red power cable through the grommet that was installed in step 1. Leave the rest of the wiring harness by foot pedals in cab of truck for now. Bring red power cable up into engine bay.

5. Route red power wire to battery. Strip red power wire on harness and add the supplied red wire from kit using butt splice, trim other end to length. Strip and add back on red power wire and fuse holder (cut off in step 4) to other end of wire using the supplied butt splice.
(Recommend using electrical tape to tape around butt splices after being installed)
6. Remove dash panel under steering wheel. First, remove plastic fuse box cover from the side of dash and then remove 2 screws with Phillips screwdriver and 1 bolt with 10mm socket on the panel. Pull straight back on panel.
7. Attach black ground wire to location shown in **Figure 3**.
8. Run Deutsch connector (on wiring harness) up through the dash and out by the driver side A pillar.
9. Drill $\frac{3}{8}$ " hole through roof in location desired; **verify that opposite side of roof is clear of obstructions**. Insert grommet into hole. **(Recommend sealing grommet areas up with RTV Silicone after wiring is installed and verified)**
10. To get wire through roof, one of the Deutsch connectors will need to be depinned so the wiring can run through the grommet, depending on where you would like the Deutsch connector to plug in at. To depin Deutsch connector, remove green or orange plastic end clip and use small flat screwdriver to unclip pins while pulling gently on wiring. When reassembling, verify corresponding wires match opposite Deutsch connector before repining. (Other option is to cut Deutsch connects off and butt splice corresponding wires together)
11. Drill $\frac{3}{4}$ " hole and notch (as explained in light bar instructions) in desired location for the supplied switch. **(Recommended location is on dash panel under steering wheel)**
12. Attach wire to switch and install as stated in the light bar instructions.
13. Attach red positive wire to battery; verify that the light bar turns on.
14. Mount relay under dash, use zip ties to secure wiring.
15. Reassemble inside and outside of truck, ENJOY!!!!



Figure 3