

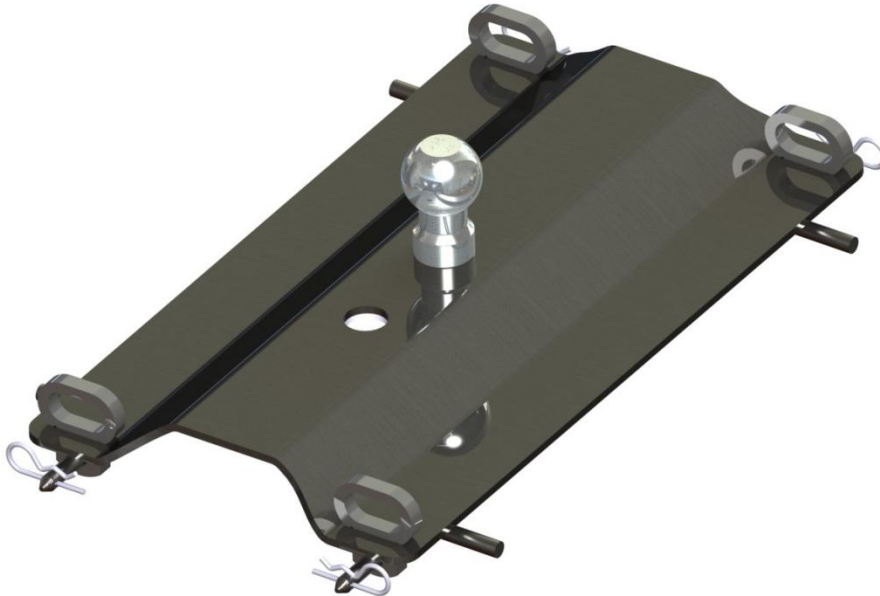

OWNER'S MANUAL



25K Super 5th Industry Standard Gooseneck

(Part #2111)

Gross Trailer Weight (max.) 25,000 lbs.

Max Tongue Weight (max.) 6,250 lbs.

The Following instructions will provide valuable information regarding the function and proper use of the PullRite Super 5th Industry Standard Gooseneck Towing System. Please take the necessary time to read these instructions completely before attempting to use your Super 5th Industry Standard Gooseneck.

YOU MUST COMPLETELY READ THE INSTRUCTIONS WITHIN THIS MANUAL PRIOR TO OPERATING THE HITCH TO PREVENT UNNECESSARY DAMAGE TO THE HITCH AND/OR YOUR VEHICLE.

INDEX

HITCH SPECIFICATIONS	Cover
PARTS LIST	2
ADJUSTABLE GOOSENECK ADJUSTABLE BALLMOUNT	3
SUPER 5 th GOOSENECK MAINTENANCE	3
HITCHING UP INSTRUCTIONS	4
WARRANTY	5
WARRANTY REGISTRATION	6

PARTS LIST

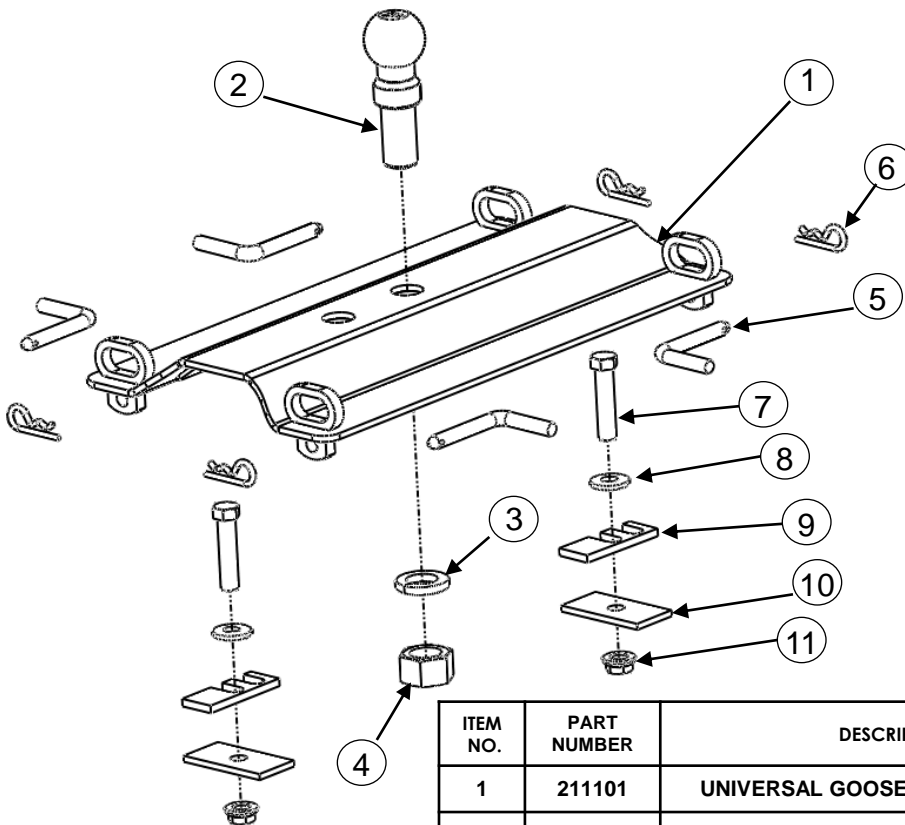

Figure 1

NOTE: ITEMS 7 – 11 ARE INCLUDED TO MOUNT THE UNIVERSAL RAIL TO THE TRUCK BED AT CENTER OF RAIL. IF YOUR VEHICLE HAS CENTER BOLTS IN BOTH RAILS THEN ITEMS 7 – 11 WILL NOT BE USED.

ITEM NO.	PART NUMBER	DESCRIPTION	QTY
1	211101	UNIVERSAL GOOSENECK ASSEMBLY	1
2	21110201	2 5/16 GOOSENECK BALL	1
3	21110202	1 1/4" LOCK WASHER	1
4	21110203	1 1/4 - 12 HEX NUT	1
5	27090001	HITCH PIN	4
6	98410143	HITCH CLIP	4
7	98010217	5/8 - 11 X 3.0" HEX HEAD GRADE 5 BOLT	2
8	98200171	CONICAL WASHER	2
9	27210202	BED CHANNEL SPACER SHIM	2
10	27210203	5/8" CENTER HOLE SHIM	2
11	98150200	5/8" - 11 SERRATED FLANGE NUT	2

ADJUSTABLE GOOSENECK BALL MOUNT

To adjust gooseneck ball mount to one of three positions (See Figure 2):

1. Place Gooseneck Assembly secure on a table.
2. Remove the 1 ¼" nut that attaches the Gooseneck Ball to the Gooseneck Assembly. (Use 1 5/8" socket and pipe wrench)
3. Position the Gooseneck Ball to the correct position, the Gooseneck Ball must be at Center Line of rear axle or forward of rear axle and reinstall 1 ¼" nut and lock washer.
4. Torque nut to 250 lbs.-ft. or see Gooseneck Ball Owner's Manual for the torquing requirements.

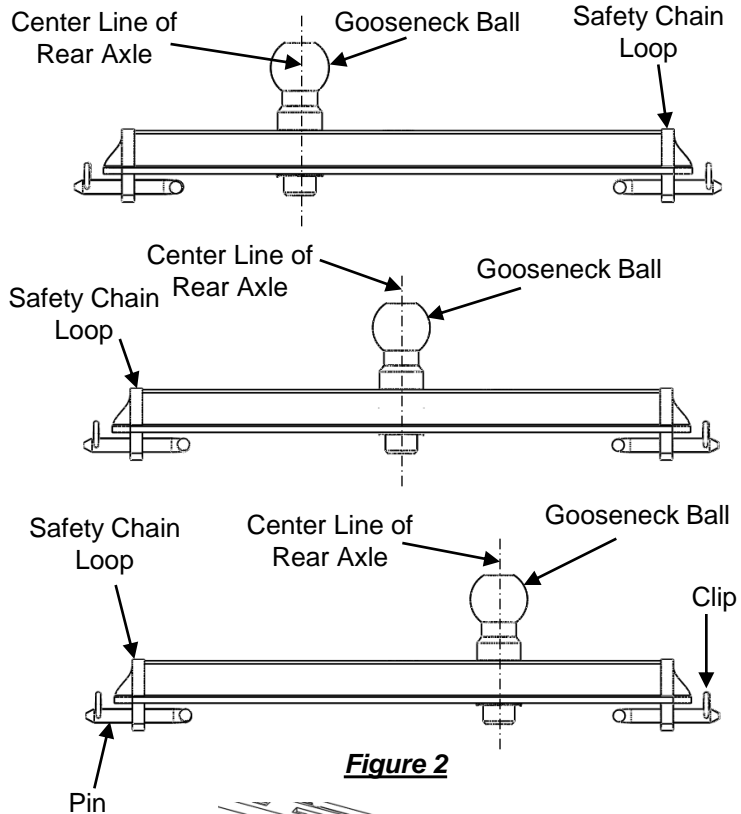

Figure 2

WARNING: Prior to drilling any holes, be sure to check the inside of the frame to guard against drilling into the fuel tank, wiring, brake lines or fuel modules.

5. If your Universal Rails do not have a center bolt, a center bolt must be installed. Use the bolt, conical washer, shims, and flange nut in the kit to secure the center of the rails. Use a 5/8" drill bit. Match drill at the center hole of the rail.
6. Install bolt, conical washer, spacer shim, hole shim, and flange nut. Torque the 5/8" bolts to 150 lbs - ft.
7. Reinstall Gooseneck Assembly, Clevis Pins, and Clips with ball at center line of axle.

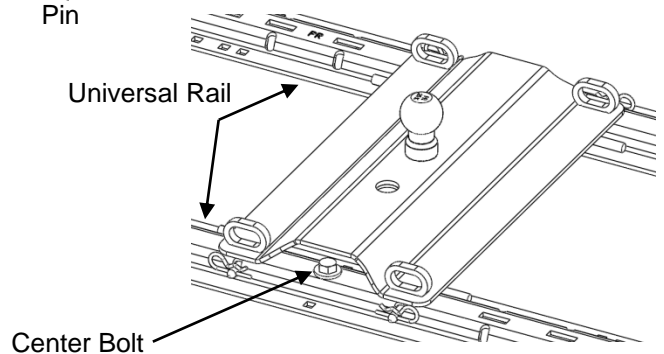

Figure 3

SUPER 5TH INDUSTRY STANDARD GOOSENECK MAINTENANCE

LUBRICATION:

◆ BASE RAIL RELEASE PINS

A light coating of oil (WD-40) will make these easy to install and remove.

◆ GOOSENECK BALL

Wipe all surfaces with a rag to remove loose dirt & rust. Spray WD-40 or other lubricant on the Gooseneck Ball and Gooseneck coupler.

OTHER:

◆ FASTENERS

Inspect all of the mounting bolts (above and below the bed) periodically for tightness and general condition.

HITCHING UP

WARNING: Never perform any of the following actions while any part of any one is between either vehicle in any way.

1. Block the trailer wheels so that it will not roll back.
2. Read your truck and trailer documentation for the correct way to hook up your gooseneck trailer.
NEVER EXCEED THE LOWEST RATING OF ANY COMPONENT OF YOUR TOWING SYSTEM.
3. Lower the truck tail gate and back up until gooseneck ball is over the gooseneck coupler.
4. Lower the trailer jacks so that the gooseneck coupler slides down on the gooseneck ball.
5. Be sure that the Gooseneck Coupler Release Handle has actuated to the closed position or manually close the gooseneck coupler.
6. Most States require the use of safety chains on gooseneck trailers for the secondary connection between the trailer and tow vehicle. They must be used **EVERY TIME YOU TOW**. Attach the chains securely to the Safety Chain Loop so they can not bounce loose. Leave only enough slack to permit full turning. Too much slack may prevent chains from maintaining control if coupler loses connection with the trailer and separates with tow vehicle.

SAFETY CHECKS: Perform the following Safety Checks at this time:

1. Review Safety Chains making sure that they are properly secured. (An example is shown on Figure 4.)
2. Review Release Handle of the gooseneck making sure the coupler is closed.
3. Raise the trailer jack base plates just above the ground, lock your trailer brakes, then pull the tow vehicle.
4. When you are assured that the trailer is safely hitched up, raise your trailer jacks into their full retracted position, connect the trailer electrical cable, trailer break-away cable and close the truck tail gate.
5. **YOU ARE NOW READY TO TRAVEL.**

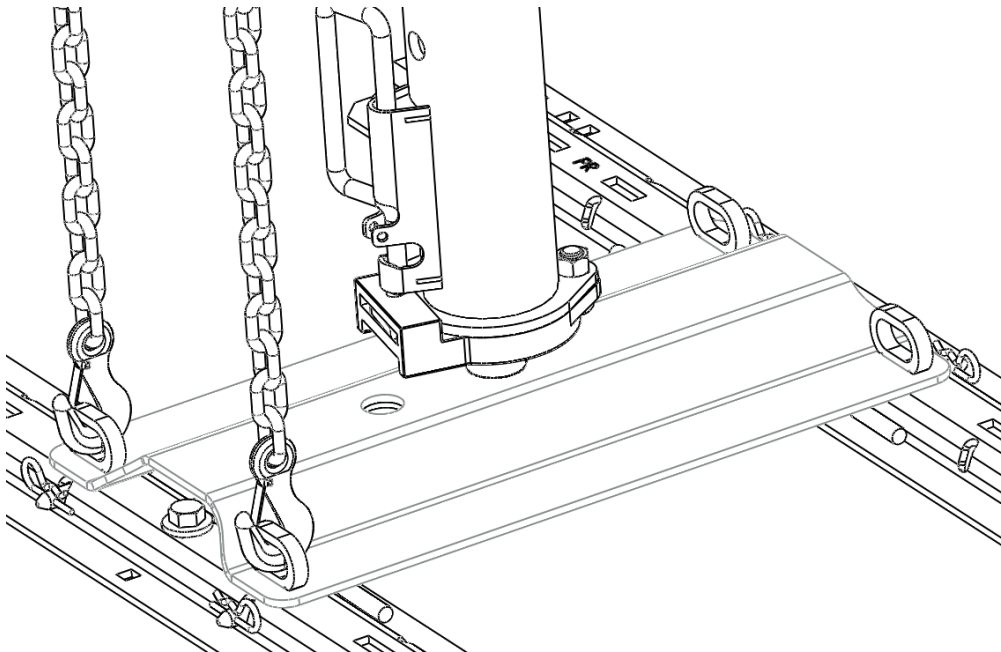

Figure 4

FIVE YEAR LIMITED WARRANTY

PULLIAM ENTERPRISES, INC. hereinafter referred to as "PULLIAM", warrants to the first retail owner only, this PullRite towing system to be free from defects in materials and workmanship for a period of five (5) years after the installation on purchaser's vehicle.

To validate this warranty, the first retail owner must mail the provided warranty card to PULLIAM within ten (10) days after installation of said towing system on his vehicle.

The owner is responsible for all normal and preventive maintenance described in the Owner's Instructions.

If any defect occurs which the owner believes is covered by this warranty within said five (5) year period, the owner shall contact **PULLIAM immediately, either in writing or by telephone call, Attention Customer Service Department. The owner will be instructed** to return the hitch at his expense either to an authorized PullRite dealer or to PULLIAM to repair or replace any parts necessary to correct defects in material or workmanship.

Repair or replacement shall be at the sole option of PULLIAM and shall be completed by or on behalf of **PULLIAM free of charge** for materials and labor.

This warranty gives you specific legal rights, and you may also have other rights which vary from state to state.

THIS WARRANTY SPECIFICALLY EXCLUDES EACH OF THE FOLLOWING:

1. Defects in the product resulting from misuse, neglect, accident, loading beyond the vehicle's capacity, failure to comply with instructions contained in the Owner's Instruction or unauthorized repairs, replacements, alterations or modifications. "Unauthorized repair, replacements, alterations" are those made without PULLIAM'S prior knowledge and consent.
2. Any incidental or consequential damage including, but not limited to, loss of use of the vehicle, towing charges, vehicle rental, loss of time, inconvenience, travel, gasoline, lodging and telephone expenses, loss of revenue and damages on account of personal injury and property damage. (Some states do not allow the exclusion or limitation of incidental or consequential damages, so these limitations may not apply to you).
3. Repairs or replacements of defects in any PullRite towing system, or part thereof, installed on any vehicle which has been rented, leased or used for any commercial purpose.
4. Any representation, warranty of undertaking made by any dealer or third party beyond the scope of the warranty herein expressed.
5. Any problem resulting in normal deterioration due to wear or exposure.

TO THE EXTENT PERMITTED BY LAW, IMPLIED WARRANTIES OF MERCHANTABILITY AND FITNESS FOR A PARTICULAR PURPOSE ARE LIMITED IN DURATION TO FIVE YEARS FROM THE DATE OF INSTALLATION ON THE FIRST OWNER'S VEHICLE. (SOME STATES, HOWEVER, DO NOT ALLOW LIMITATIONS AS TO DURATION OF IMPLIED WARRANTY, SO THOSE LIMITATIONS MAY NOT APPLY TO YOU)

PULLRITE TRAILER TOWING SYSTEMS





Product Warranty Registration

As an owner of a PullRite product, you must register your product to be considered for warranty coverage. See Owners Manual for further details.

Name: _____

Address: _____

City: _____ State: _____ Zip: _____

Email Address: _____

Phone (optional): _____

Purchase Price: _____ Date of Purchase: _____

Dealer's Name: _____

Dealer's Address: _____

Dealer's City: _____ Dealer's State: _____ Dealer's Zip: _____

Dealer's Phone: _____

Model Purchased: _____

Vehicle Make: _____ Vehicle Model: _____ Vehicle Year: _____

Vehicle Year: _____ Vehicle Cab Style: _____ Vehicle

Bed Length: _____

Did you receive an Owners Manual from the Dealer? Yes / No

What influenced you to buy your hitch? _____

Comments: