



Emergency Top Installation Instructions

- For:
- Jeep CJ
1976 – 1991
Part Number: 56810
 - Jeep YJ
1992 – 1995
Part Number: 56811
 - Jeep TJ
1997 – 2006
Part Number: 56812
 - Jeep TJ Unlimited
2004 – 2006
Part Number: 56813
 - Jeep JK
2007 – Current
Part Number: 56814
 - Jeep JK Unlimited
2007 – Current
Part Number: 56815



 **WARNING** Emergency Top is meant to be used for short, low speed trips.

Installation Tips

Before you begin installing this assembly, read all instructions thoroughly.

For a smooth fit:

For ease in installation, the product should be installed at temperatures above 72° F. Below this temperature, the fabric may contract an inch or more, making it difficult to fit to the vehicle. It is normal for fabric to contract and wrinkle when stored in the shipping carton. Within a few days after the installation, the fabric will relax and the wrinkles will disappear.



WARNING

This product is designed to enhance the appearance of the vehicle. Do not rely in any way on the components of this product to contain occupants within the vehicle, or to protect against injury or death in the event of an accident. Never operate vehicle in excess of manufacturer's specifications.

WEAR SEAT BELTS AT ALL TIMES

Read and follow, precisely, all installation instructions provided when installing this product. Failure to do so could place occupants of the vehicle in a potentially dangerous situation. After installing or reinstalling, check to make sure it has been properly installed.



CAUTION

Safety glasses should be worn at all times while installing this product.

Parts List

Emergency Top	Qty - 1
Personal Ponchos	Qty - 2

Step One

INSTALL REAR STRAPS

Orient the Emergency Top on the vehicle. Locate the three elastic straps (one strap on JK models) sewn to the rear of the top. Hook the center strap around the spare tire carrier and the outside straps around each rear taillight (excluded on JK models, Part Numbers 56814 and 56815).

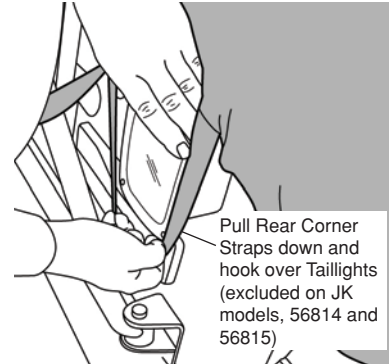
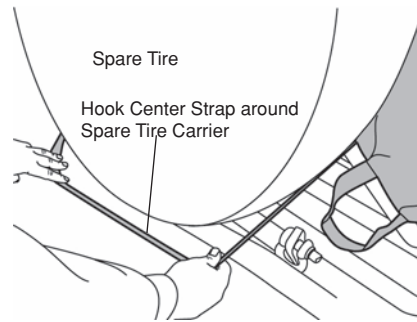

Step Two

INSTALL THE ADJUSTABLE STRAPS

Locate the three adjustable straps. Hook the corner straps to the door hinge on each side of the vehicle and the center strap to the hood loop. Do not tighten the straps at this time.

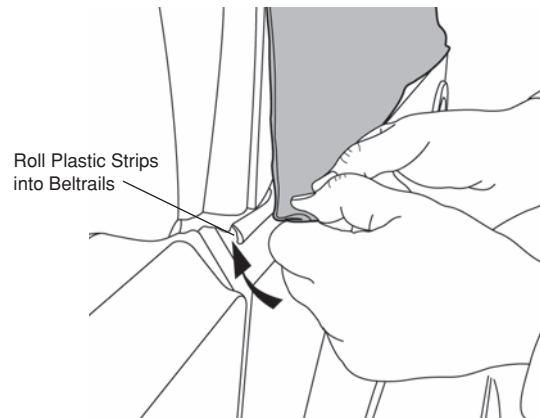
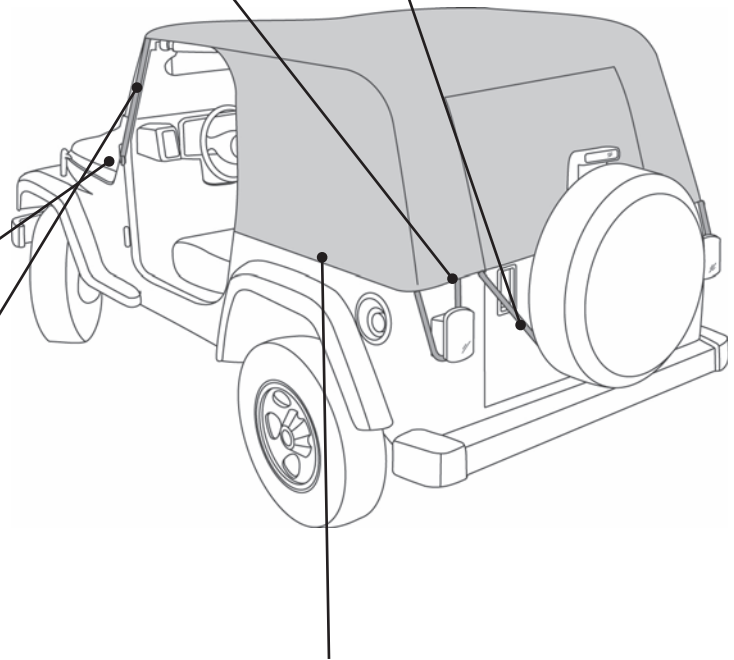
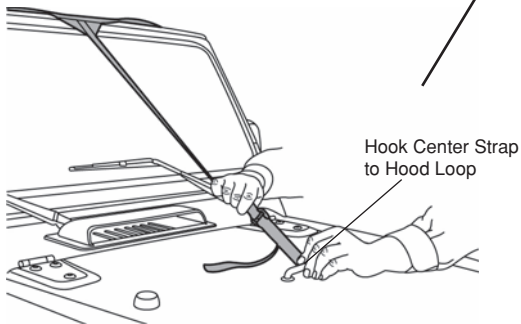
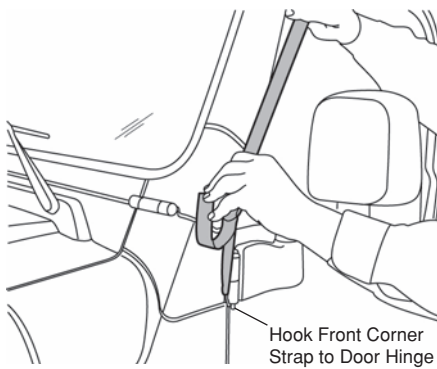

Step Three

SECURE TOP IN BELTRAILS

Slip the plastic strips on the sides of the top into the beltrails on the vehicle.

Step Four

SECURE SPORT BAR FLAPS

Wrap the flaps above the doors around the sport bars and fasten the hook and loop strips to each other.

Wrap Flap around Sport Bar and fasten Hook and Loop.

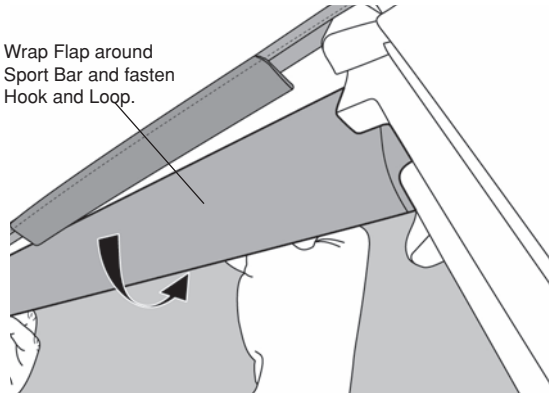

Step Five

SECURE TOP TO DOOR SURROUNDS (1997 – CURRENT VEHICLES)

If your vehicle has door surrounds, snap the plastic retainers into the channel in the door surrounds.

Roll Plastic Strip into Door Surround

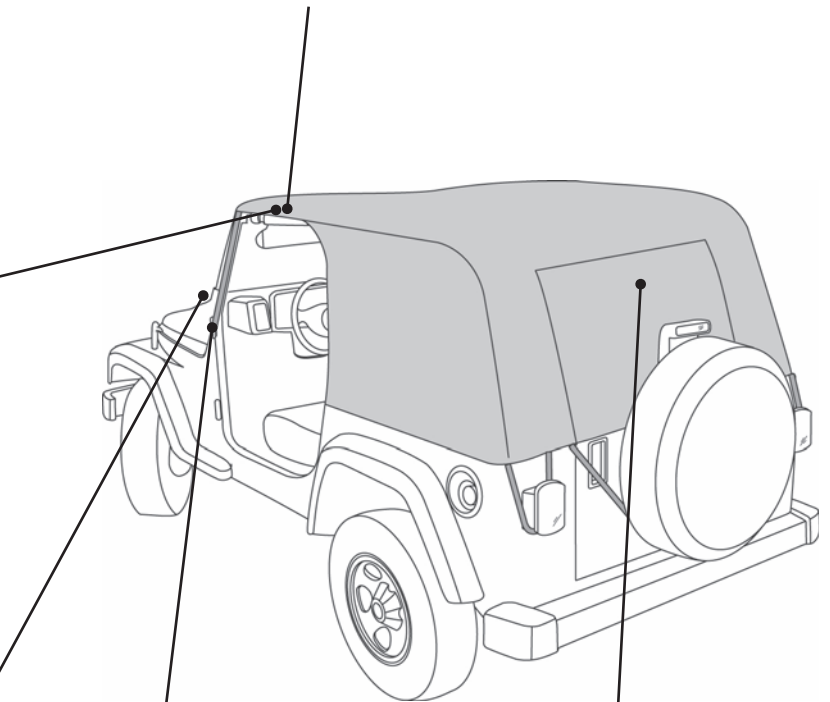
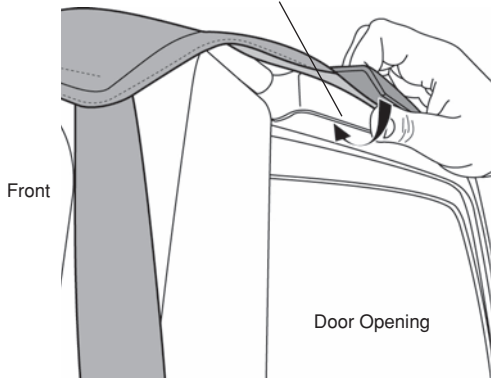

Step Six

TIGHTEN THE ADJUSTABLE STRAPS

Pull the end of each adjustable strap to tighten them to the door hinges and the hood loop.

Pull end of strap to tighten

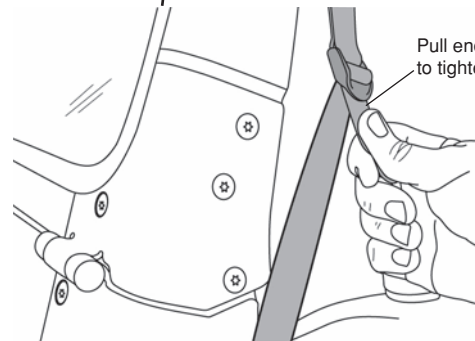

Strap hooks to Door Hinge

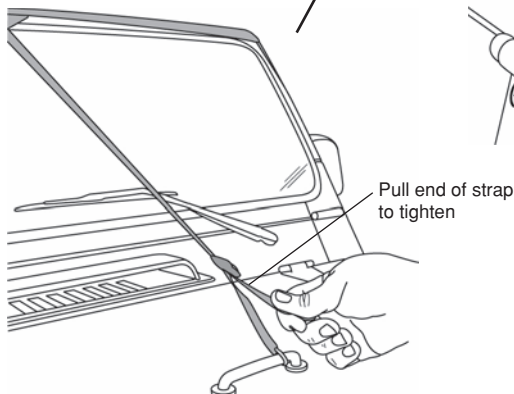

Pull end of strap to tighten

Step Seven

ROLL THE REAR WINDOW

The rear window may be rolled up for greater visibility.

Care and Maintenance of your Emergency Top

Your Emergency Top is made of the finest materials available. To keep it looking new and for the maximum possible wear, it will need periodic cleaning and maintenance.

Washing: The fabric should be washed often using soap, warm water and a soft bristle brush. Rinse with clear water to remove all traces of soap or use Bestop-recommended Bestop Cleaner and Bestop Protectant. Bestop Cleaner and Bestop Protectant are specially formulated to provide a total cleaning and protection system. Bestop Cleaner will not harm vehicle finish, is biodegradable and environmentally friendly. Bestop Protectant protects against UV-fading, cracking and hardening.

Zippers: Keeping the zipper cleaned and lubricated with a silicone lubricant will help prevent damage and keep the zippers in a smooth working condition. If a zipper opens behind the slider, the slider may have been spread apart. This problem can usually be repaired by using an ordinary pair of pliers to bring the sides back into parallel. Return slider to the end of the zipper in the normal Open position. Squeeze lightly at first and test the zipper. If the zipper continues to remain open squeeze more firmly with the pliers and try the zipper again. Repeat this procedure until the zipper operates correctly.

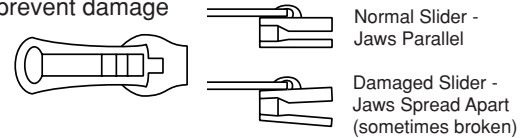

Water: Seeping through at the seams may be stopped by applying 3-M Scotchgard® on the inside of the seams. Rips in the fabric may be repaired with Bondex® iron on patches. Iron the patches to the Inside of the top, carefully following the Bondex® instructions.

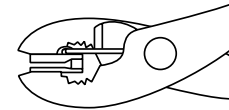

LIMITED WARRANTY

We warrant our product to be free from defects in material and workmanship, for terms specified below, provided there has been normal use and proper maintenance. This warranty applies to the original purchaser only. All remedies under this warranty are limited to the repair or replacement of any item or items found by the factory to be defective within the time period specified.

If you have a warranty claim, first you must call our factory at the number below for instructions. You must retain proof of purchase and submit a copy with any items returned for warranty work. Upon completion of warranty work, if any, we will return the repaired or replaced item or items to you freight prepaid. Damage to our products caused by accidents, fire, vandalism, negligence, misinstallation, misuse, Acts of God, or by defective parts not manufactured by us, is not covered under this warranty.

THE WARRANTY TIME PERIOD IS AS FOLLOWS: ALL "GOODS" MANUFACTURED BY OUR COMPANY: ONE YEAR FROM DATE OF PURCHASE.

ANY IMPLIED WARRANTIES OF MERCHANTABILITY AND/OR FITNESS FOR A PARTICULAR PURPOSE CREATED HEREBY ARE LIMITED IN DURATION TO THE SAME DURATION AND SCOPE AS THE EXPRESS WRITTEN WARRANTY. OUR COMPANY SHALL NOT BE LIABLE FOR ANY INCIDENTAL OR CONSEQUENTIAL DAMAGE.