



Flip Top Installation Instructions

For: Wrangler TJ 1997 - 2006

Part Number: 44527

DO NOT INSTALL THIS PRODUCT ON ANY VEHICLE OTHER THAN THOSE LISTED ABOVE.

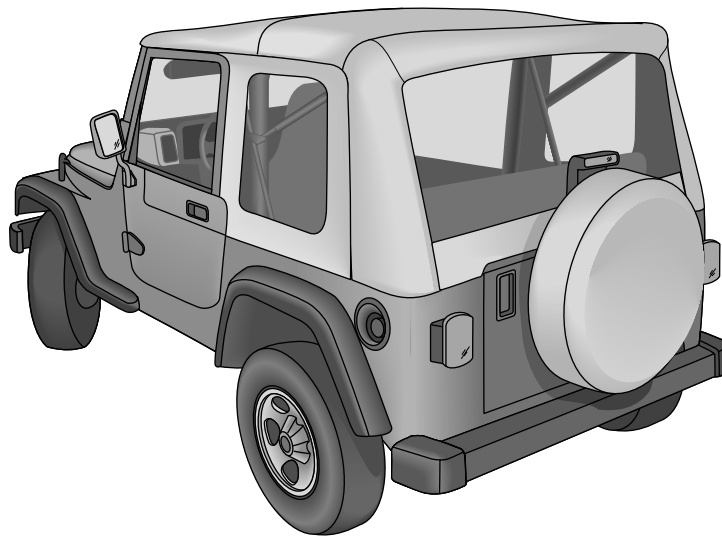

WARNING

This product is designed to enhance the appearance of the vehicle and to shield the occupants from ordinary weather conditions. Do not rely in any way on the components of this product to contain occupants within the vehicle, or to protect against injury or death in the event of an accident. This product will not protect the occupants from falling objects. Never operate vehicle in excess of manufacturer's specifications.

WEAR SEAT BELTS AT ALL TIMES

Read and follow, precisely, all installation instructions provided when installing this product. Failure to do so may result in a poor fit and could place occupants of the vehicle in a potentially dangerous situation.

Installation Tips

Before you begin installing this product, read all instructions thoroughly. Below are a few tips to make this installation easier. After completing the installation, keep these instructions for further reference.

For a smooth fit:

For ease in installation, the Flip Top should be installed at temperatures above 72° F. Below this temperature, the fabric may contract an inch or more, making it difficult to fit to the vehicle.

It is normal for the fabric to contract and wrinkle when stored in the shipping carton. Within a few days after the installation, the fabric will relax and the wrinkles will disappear.

Parts List and Hardware Identification

Top Fabric	Qty - 1
Quarter Window, Rt.	Qty - 1
Quarter Window, Lt.	Qty - 1
Rear Window	Qty - 1
Windshield Header Trim	Qty - 1

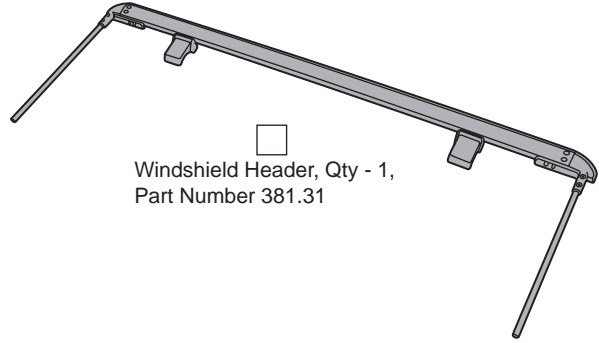

Windshield Header, Qty - 1,
Part Number 381.31

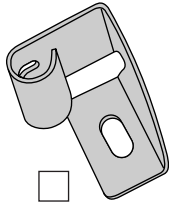

Windshield Bracket - Left,
Qty - 1, Part Number 380.97

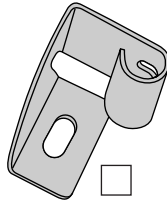

Windshield Bracket - Right,
Qty - 1, Part Number 380.96

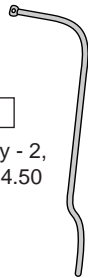

Vertical Rod, Qty - 2,
Part Number 134.50

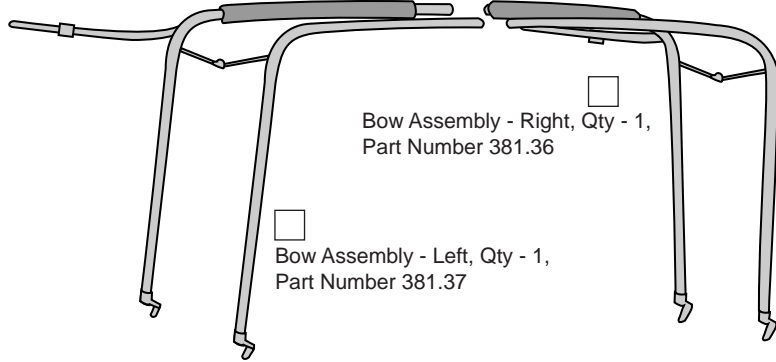

Bow Assembly - Right, Qty - 1,
Part Number 381.36

Bow Assembly - Left, Qty - 1,
Part Number 381.37

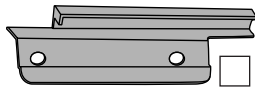

Tailgate Retainer Mount, Left,
Qty - 1, Part Number 311.85

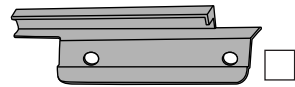

Tailgate Retainer Mount, Right,
Qty - 1, Part Number 311.86

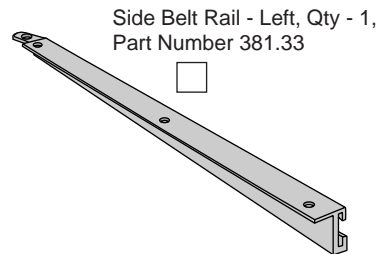

Side Belt Rail - Left, Qty - 1,
Part Number 381.33

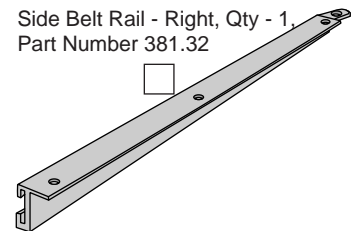

Side Belt Rail - Right, Qty - 1,
Part Number 381.32

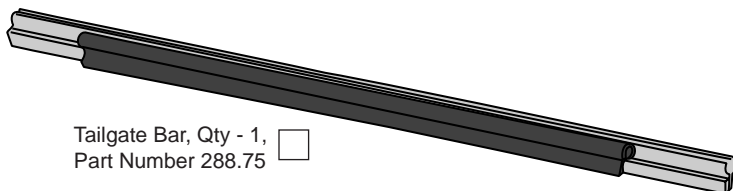

Tailgate Bar, Qty - 1,
Part Number 288.75

#8 x 1/2" Pan Head Washer Screw - Black, Qty - 4, Part Number 200.48

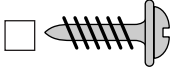

#10-15/16 Bolt, Qty - 2, Part Number 326.85

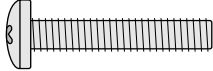

5/16" Black Washer, Qty - 6, Part Number 233.04

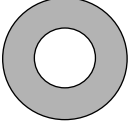

Lock Nut, Qty - 2, Part Number 316.94



5/16-18 Tapping Plate, Qty - 6, Part Number 200.50

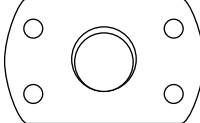

5/16-18 x 1" Phillips Bolt, Qty - 6, Part Number 236.20



Step One

INSTALL WINDSHIELD BRACKETS

Loosen the top screw on the A Pillar Molding. Use a #40 TORX Driver to remove the outboard bolt that attaches the Sport Bar to the windshield. Slide the Windshield Bracket behind the A Pillar Molding and reinstall the bolt you removed to secure the bracket to the windshield. Re-tighten the top molding screw.

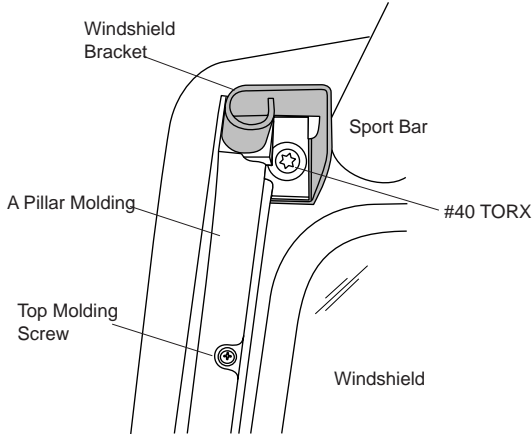

Tools Needed

1/8" Drill Bit
and Drill Motor
Center Punch
#35 Torx
#40 Torx
Ratchet

Flat Screwdriver
Phillips Screwdriver
Hammer
Pencil
Adjustable Wrench
Safety Glasses



Caution

Safety glasses should be worn at all times while installing this product.

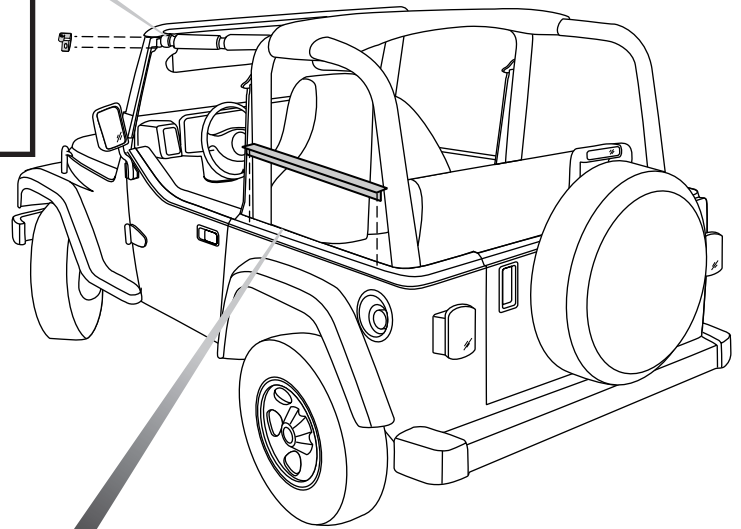

Step Two

INSTALL BELT RAILS

Install the Left and Right Side Belt Rails on each side of the vehicle. Use the existing holes, three 5/16"-18 x 1 Phillips Bolts and three 5/16"-18 Tapping Plates on each side.

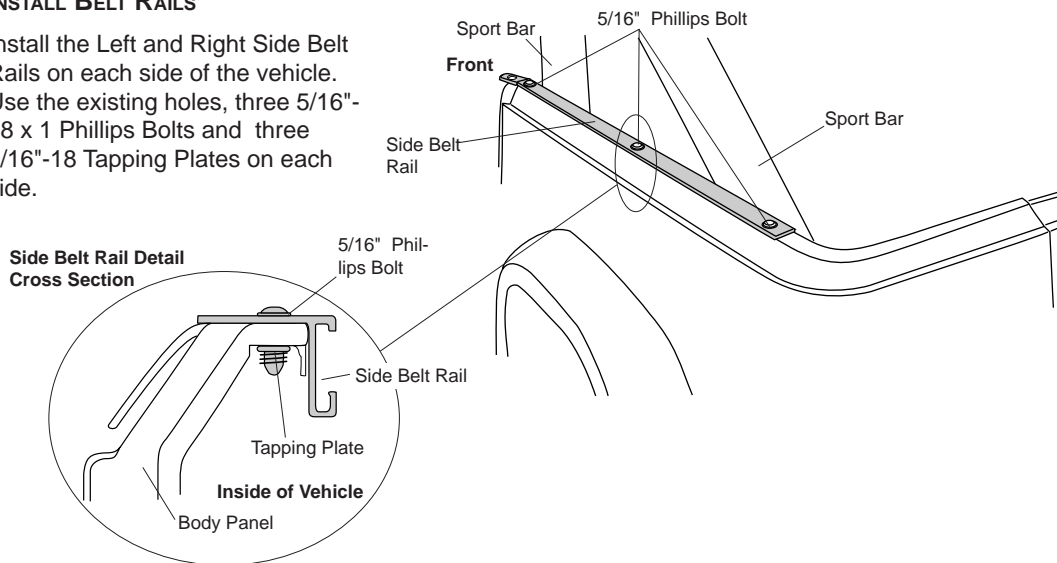

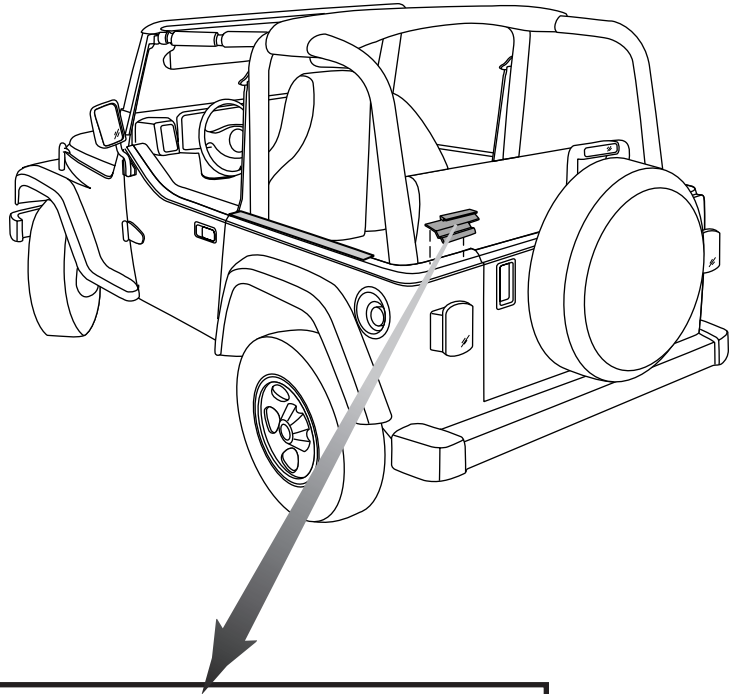

Caution

When drilling in the top edge of the vehicle body, check underneath for wiring for the rear lights. Pull the wiring out of the way before drilling.

Step Three

INSTALL THE TAILGATE RETAINER MOUNTS

Locate the left and right Tailgate Retainer Mounts. Place the mounts flush with the edge of the tailgate opening. Install the Tailgate Retainer Mounts with two #8 x 1/2" Pan Head Washer Screws for each mount.

If your vehicle does not have holes at this location, align the Tailgate Retainer Mounts flush with the edge of the tailgate opening. Then mark the locations of the holes in the mounts, center punch and drill a 1/8" hole at the marked locations. Install the mounts with two #8 x 1/2" Pan Head Washer Screws for each mount.

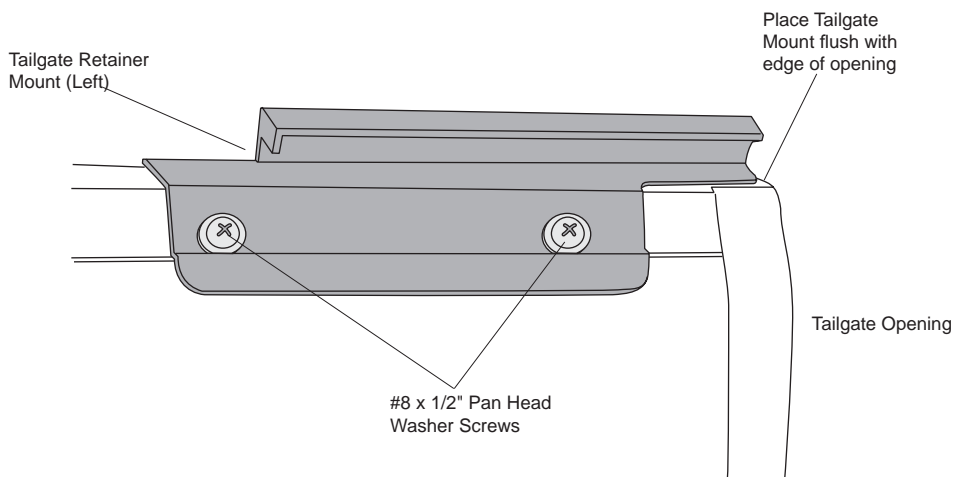

Step Four

ASSEMBLE BOW ASSEMBLY

Assemble the two halves of the support bow. Orient the two pieces to each other and lay them on the floor. Slide the pieces together, pushing down on the buttons. Once the two halves are together install a Snap Head Screw in the hole formed in the center, front of each bow. This will require a #20 TORX socket.

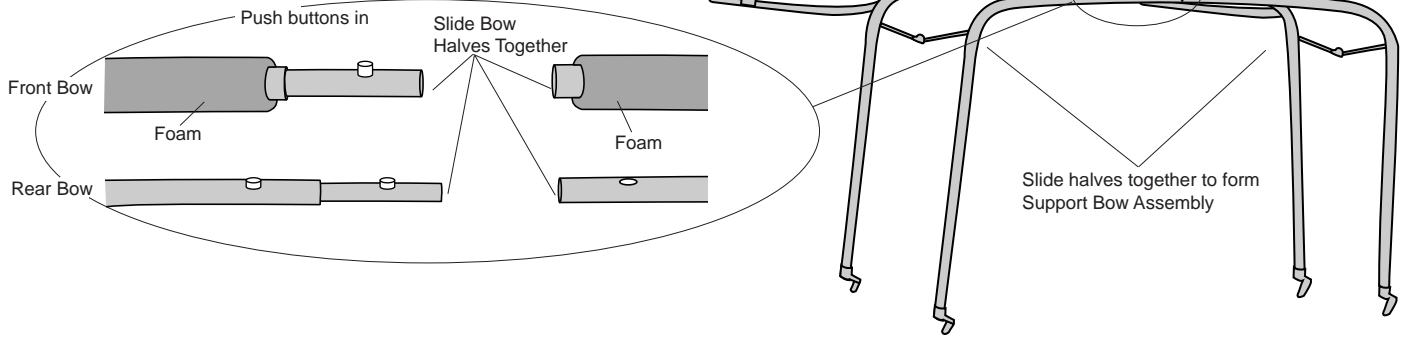

Note: It may be helpful to use a flat screwdriver to push buttons down while sliding bow halves together.

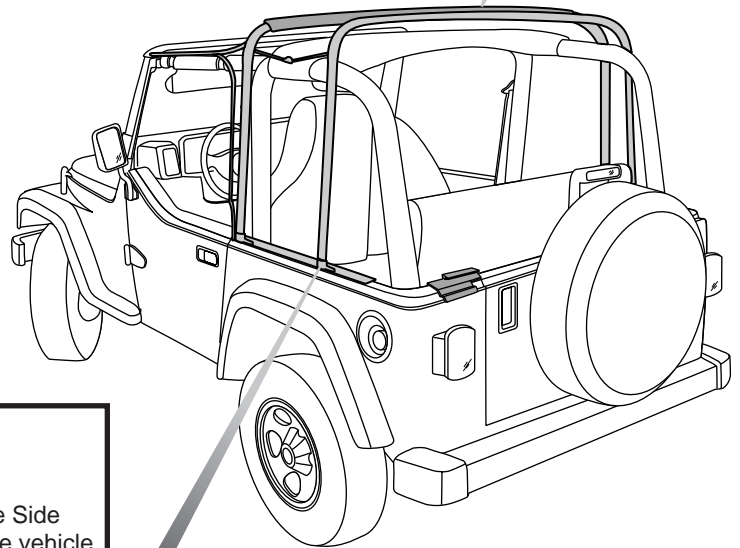

Step Five

INSTALL BOW ASSEMBLY

Slide the ends of the front and rear bows into the tracks in the Side Belt Rails on each side of the vehicle. Start from the rear of the vehicle and slide the bow assembly toward the front.

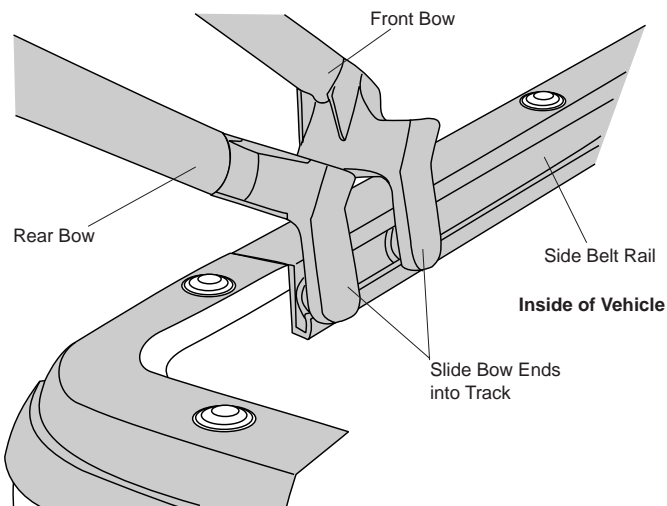

Note: It may be helpful to have two people to slide both sides of the bow assembly forward at the same time.

Step Six

INSTALL HORIZONTAL ROD

Slip the end of the Horizontal Rod into the tube on the Windshield Bracket until the spring button on the rod pops up through the hole in the Windshield Bracket.

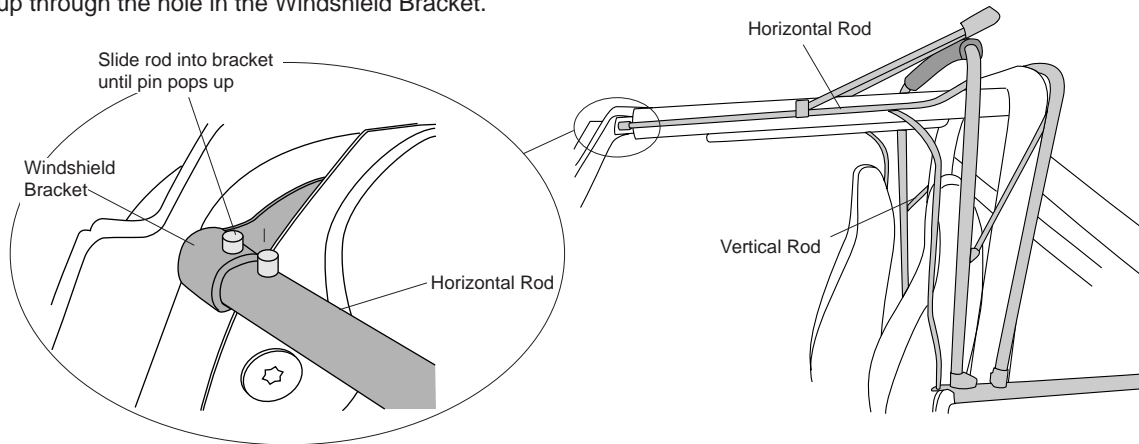

Note: The pin must pop up through the hole in the Windshield Bracket for proper fit.

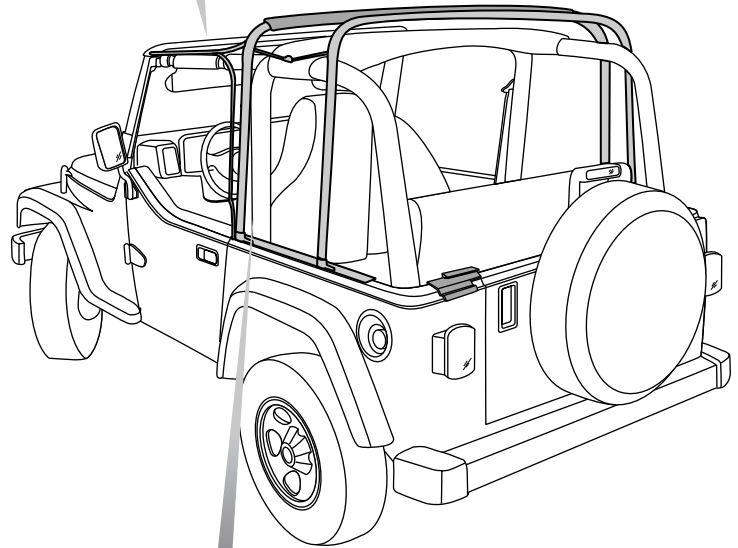

Step Seven

INSTALL VERTICAL ROD

Place the bottom of the Vertical Rod into the hole at the front of the Side Belt Rail. Bolt the rod to the Horizontal Rod on the Bow Assembly with the Screw and Nut attached to the Horizontal Rod.

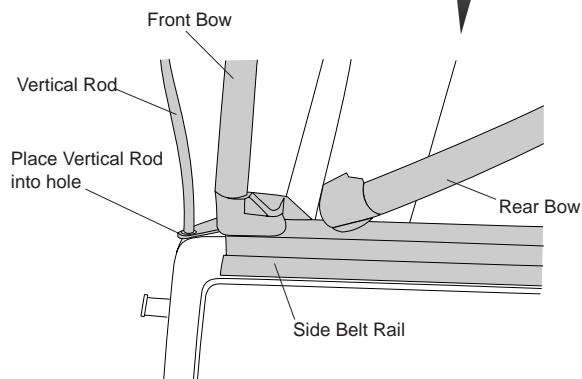

Step Eight

INSTALL WINDSHIELD HEADER

Orient the Windshield Header on the vehicle. Lay the header on top of the bows with the snap studs facing up. Place the legs of the header into the bracket above the door opening on each horizontal rod. Install the legs in the brackets with a #10-15/16 Bolt and Lock Nut on each side.

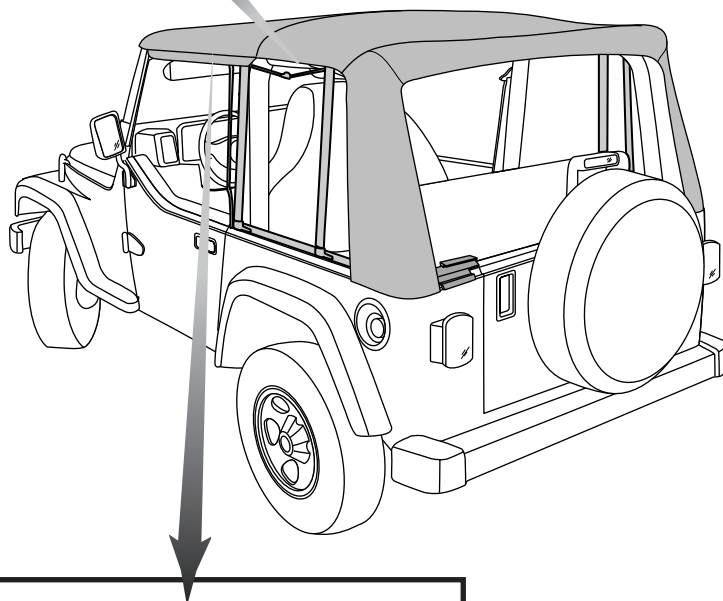
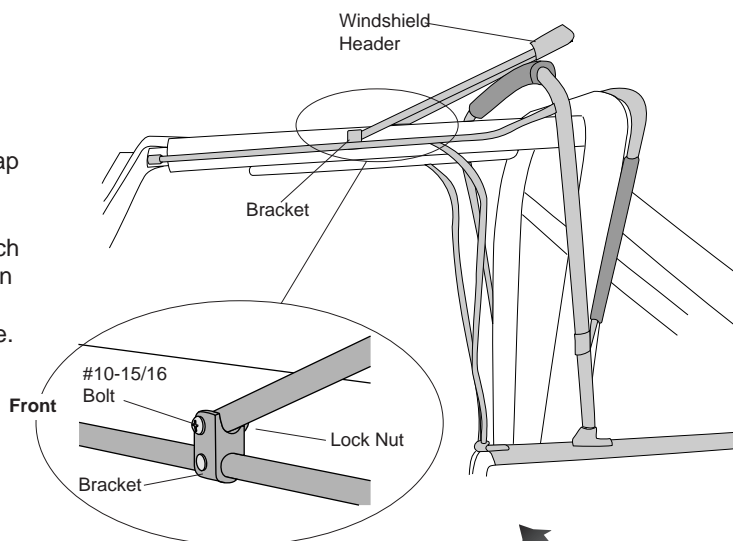

Step Nine

INSTALL TOP TO HEADER

Pull the deck up over the center bow to the Windshield Header Assembly. Open the Sun Roof and stand inside the vehicle to access the front of the assembly. Wrap the front edge of the Top Fabric around the front edge of the Windshield Header Assembly. Make sure that the fabric is centered on the header. Press the plastic retainer along the front of the top into the channel on the header until it **snaps** into the channel.

Wrap Fabric around
Windshield Header and
snap plastic retainer into
channel in header

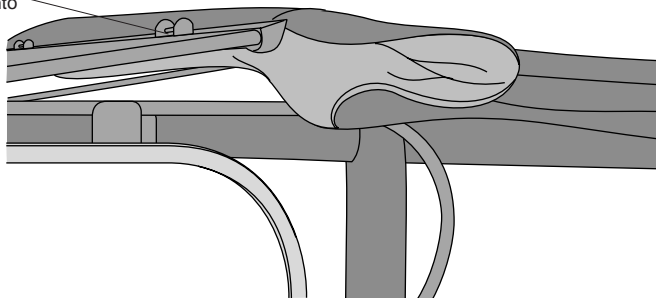

Note: Make sure the plastic retainer is snapped firmly into the Header channel. The Sun Roof feature will not work properly if the retainer is not securely installed.

Step Ten

SNAP TOP TO BOWS

Drape the top over the rear of the vehicle and snap it to the bows.

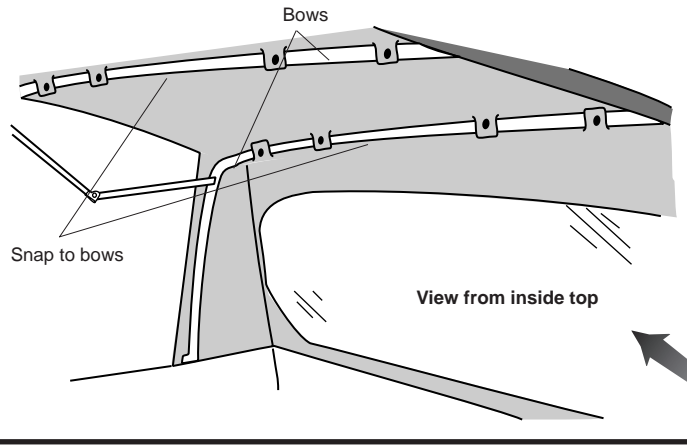

Step Eleven

POSITION FRONT BOW

Push the front support bow all the way forward. The bow must slip into notch in belt rail.

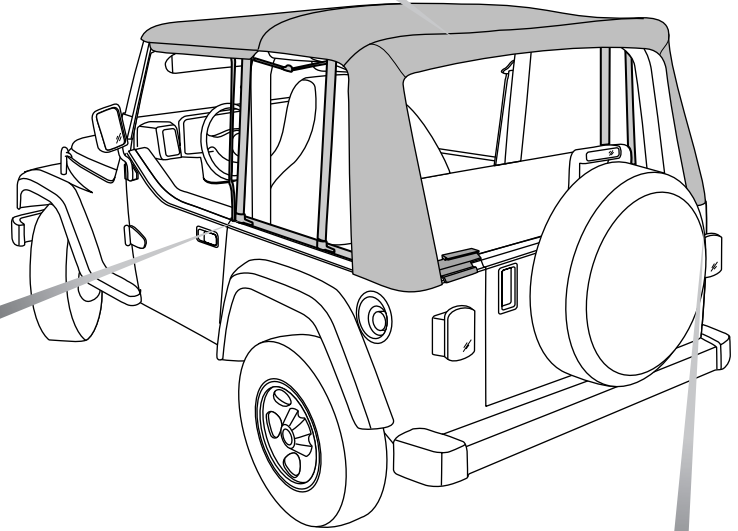
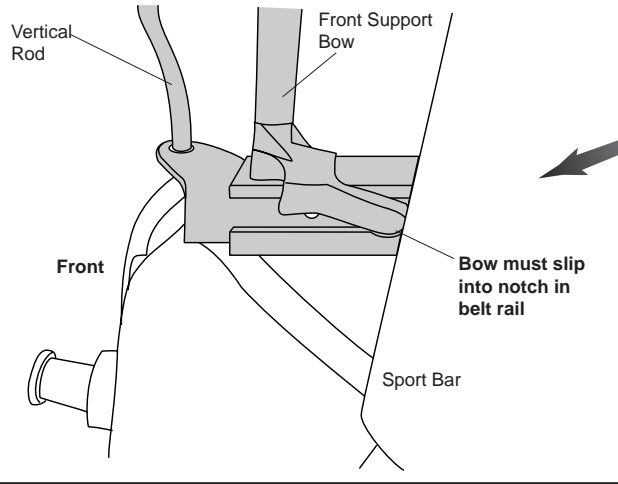

Step Twelve

SECURE REAR CORNERS

Insert the rear corners of the top into the Rear Corner Retainers.

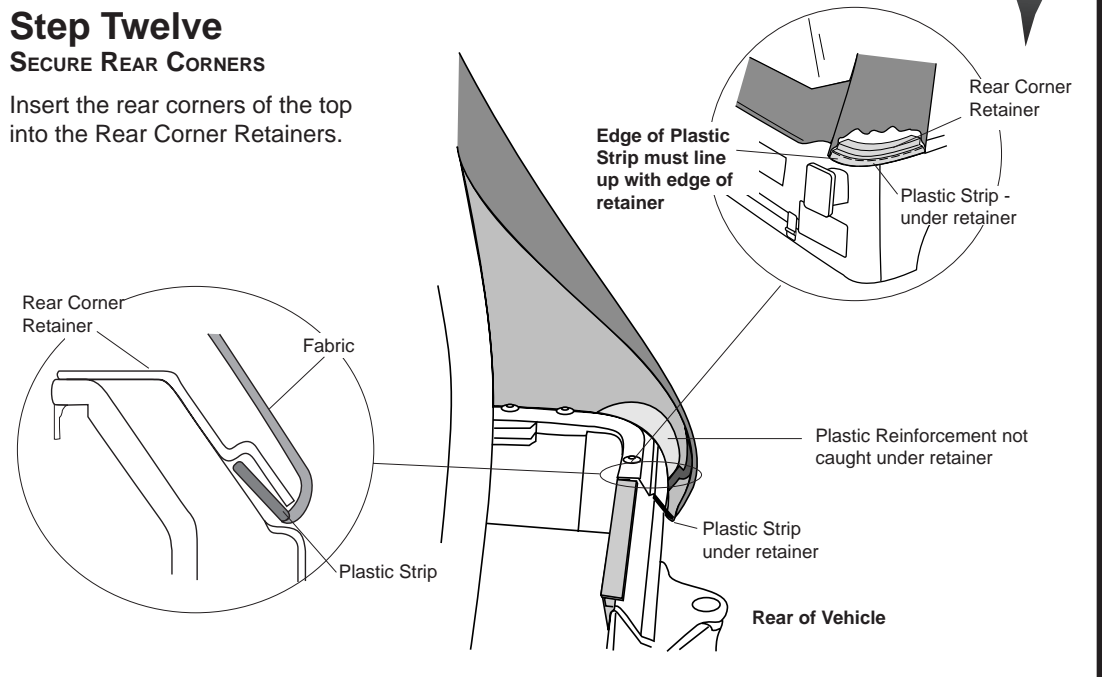

Step Thirteen

POSITION REAR SUPPORT BOW

Pull the bottom of the rear support bow back until it snaps into the notch in the side rail. Make sure that the zippers are not caught or folded behind rear support bow and that the bow slips into the notch in the Side Belt Rail.

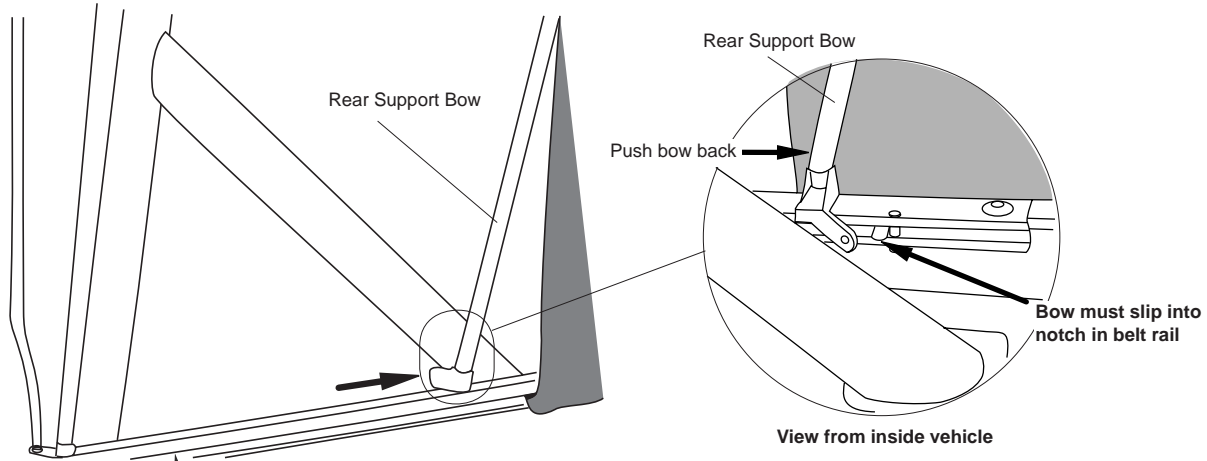

Step Fourteen

POSITION SPREADER BARS

Push the spreader bars up until they snap into place.

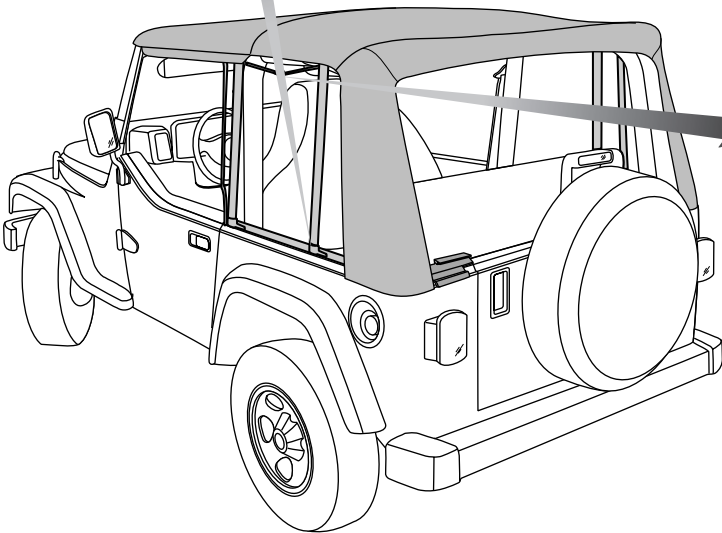
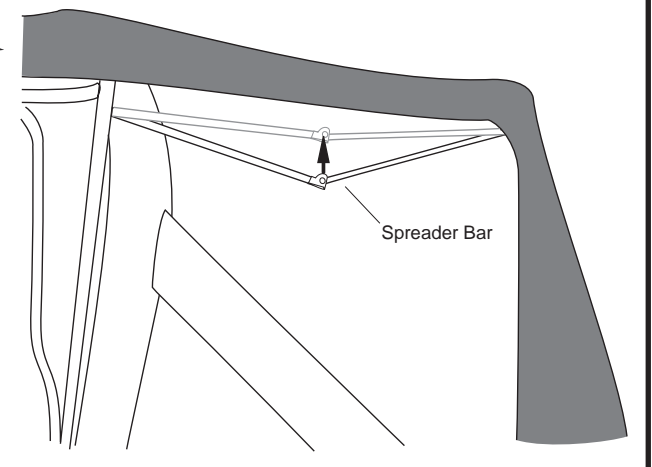

Step Fifteen

INSTALL QUARTER WINDOWS

Start the top and rear zippers on the Quarter Windows 2-3 inches.

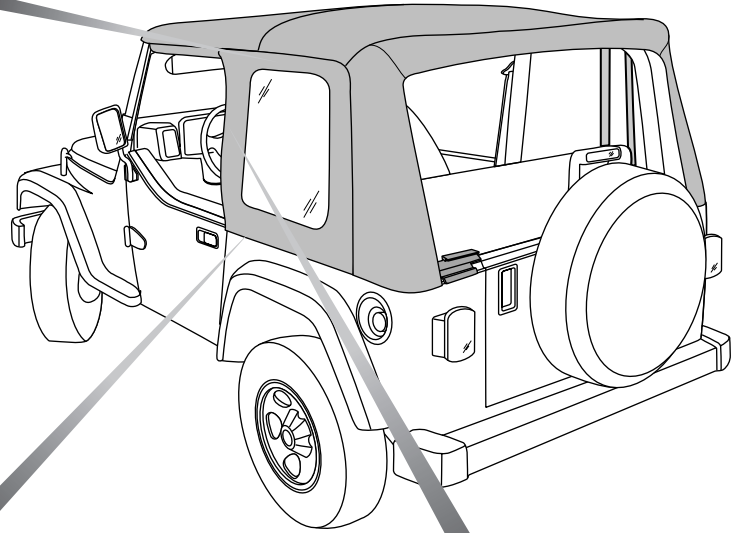
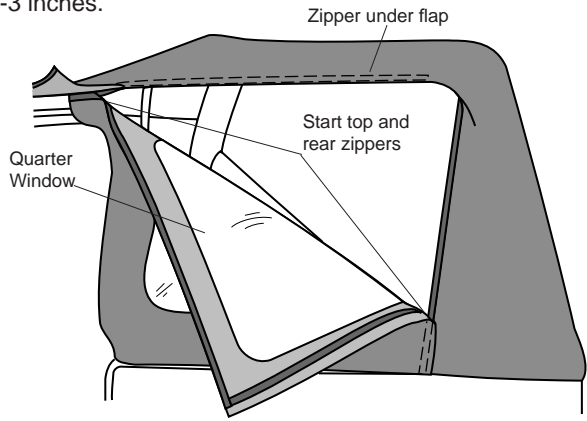

Step Sixteen

INSTALL QUARTER WINDOWS

Slip the plastic strip on the bottom of the Quarter Window into the Side Belt Rail. Close the top and rear zippers on the side curtain.

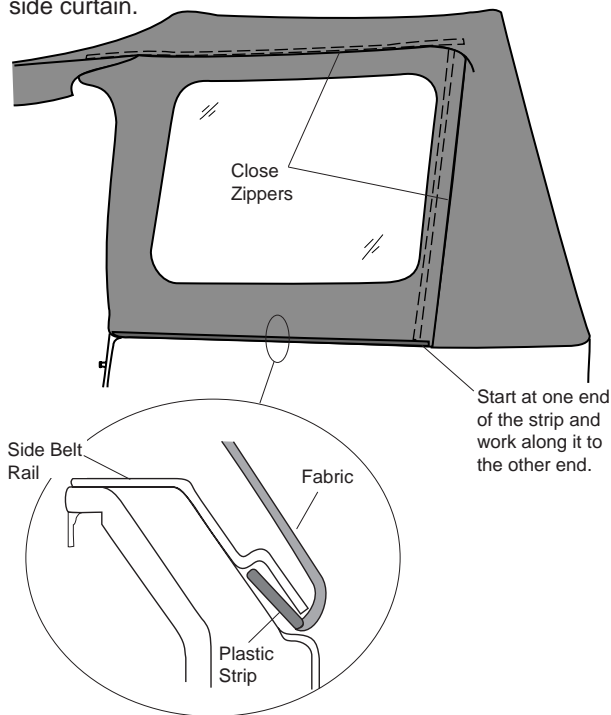

Step Seventeen

INSTALL QUARTER WINDOWS

Wrap fabric flap on the front of the side curtain around the Vertical Rod (not the front bow) and fasten the hook and loop strips to each other.

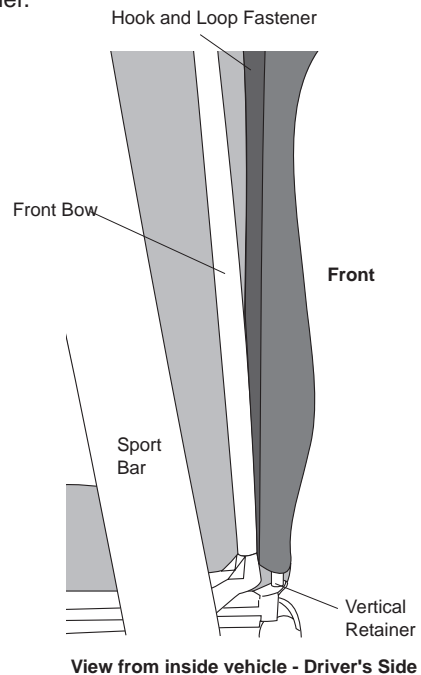

Step Eighteen

SECURE DOOR OPENING

Wrap the flap, sewn to the top above each door, around the Horizontal Rod and fasten the hook and loop strips to each other.

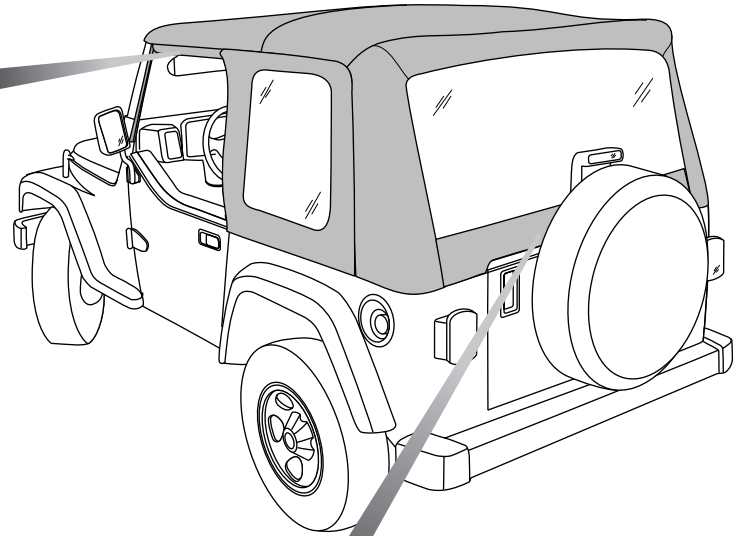
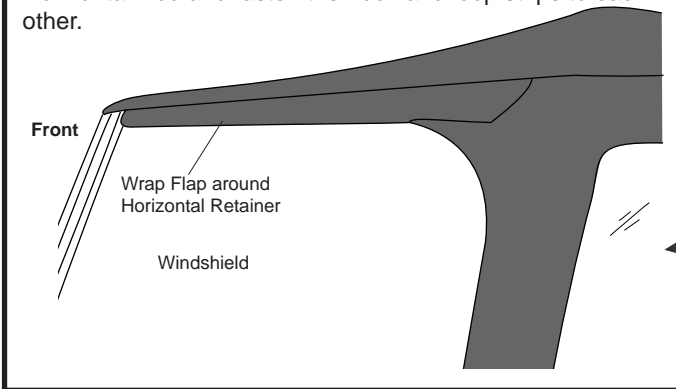

Step Nineteen

INSTALL TAILGATE BAR

Open the tailgate. Orient the Rear Curtain Retainer with the rubber bulb facing down, in order to form a seal with the top of the tailgate. Slide the groove in the Rear Curtain Retainer onto the tube inside the bottom of the Rear Curtain. Roll the Rear Curtain Retainer into the top of the Corner Belt Rail. Slip the plastic on the bottom of the corners under the bottom of the Corner Belt Rail. Close the rear curtain zipper.

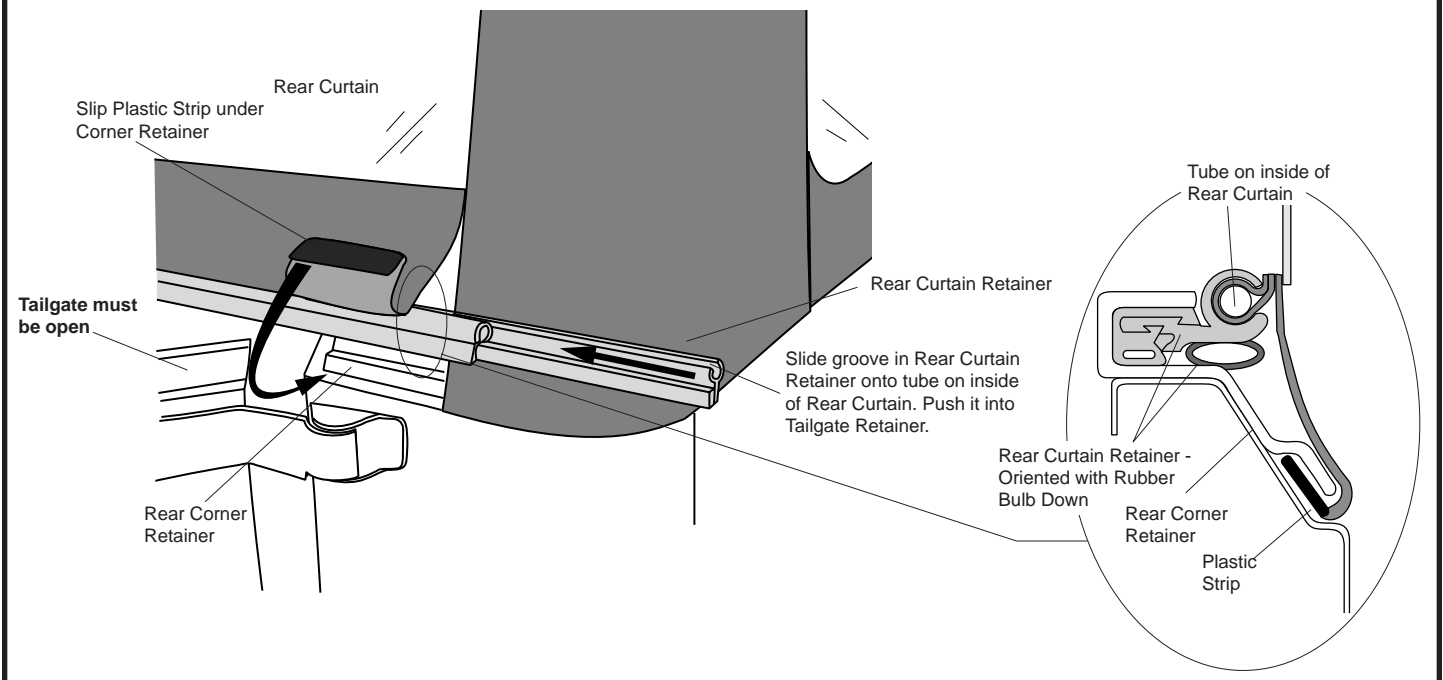

Adjusting the Top



WARNING

When operating the vehicle without the Quarter Windows, the Rear Curtain should be rolled up for proper ventilation.

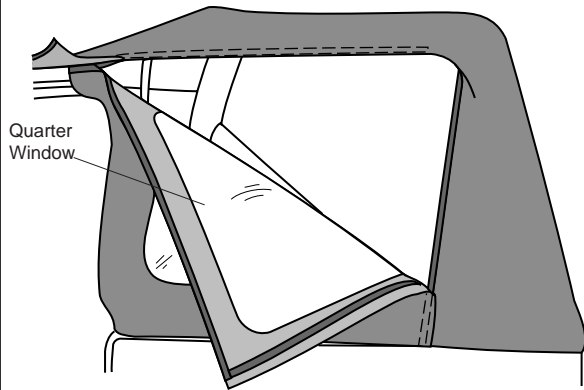

Quarter Windows

To remove the Quarter Windows. Unzip the rear and top zippers. Release the plastic strip from the retainer. Release the Hook and Loop Fasteners from around the Vertical Retainer.

Opening the Sun Roof

Release the Windshield Header Latches and fold the Windshield Retainer back so that it rests on the center bow and the sport bar.

Removal of Soft Top for Open Air Driving

When operating the vehicle with the fabric top removed, it is very important that the supporting hardware system be disconnected from the windshield bracket and folded flat to the rear of the vehicle. Wrap the elastic straps around the bows and insert the plastic strip into the Side Belt Rail. Never operate the vehicle with the fabric removed and the hardware in the fully erected position.

Care and Maintenance of your Flip Top

Your top is made of the finest materials available. To keep it looking new and for the maximum possible wear, it will need periodic cleaning and maintenance.

Washing: The top fabric should be washed often using soap, warm water and a soft bristle brush. Rinse with clear water to remove all traces of soap.

Windows: Keep windows clean to avoid scratching. DO NOT use a brush on the windows! Wash with a water-soaked cloth or sponge and a mild dishwashing detergent. NEVER WIPE THE WINDOWS WHEN THEY ARE DRY. Be careful when cleaning snow or frost from the vinyl windows since they are easily scratched and may crack at low temperatures. DO NOT roll the sides or rear window in cold weather. The windows become stiff and will crack.

Zippers: Keeping the zipper cleaned and lubricated with a silicone lubricant will help prevent damage and keep the zippers in a smooth working condition. If a zipper opens behind the slider, the slider may have been spread apart. This problem can usually be repaired by using an ordinary pair of pliers to bring the sides back into parallel. Return slider to the end of the zipper in the normal Open position. Squeeze lightly at first and test the zipper. If the zipper continues to remain open, squeeze more firmly with the pliers and try the zipper again. Repeat this procedure until the zipper operates correctly.

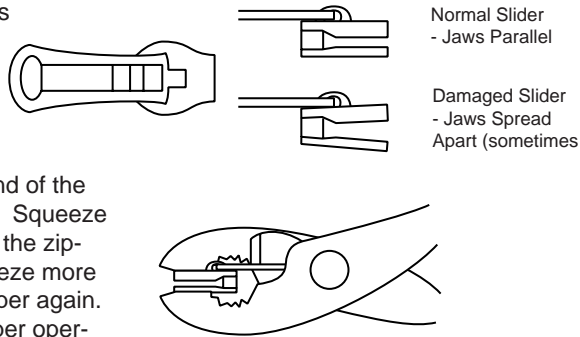

Water: Seeping through at the seams may be stopped by applying 3-M Scotchgard® on the inside of the seams. Rips in the fabric may be repaired with Bondex® iron on patches. Iron the patches to the inside of the top, carefully following the Bondex® instructions.

Snaps: Keep snaps cleaned and lubricated with silicone to help prevent snaps from sticking to the studs. If a snap does become stuck to a stud, use a screwdriver and GENTLY pry apart to prevent permanent damage to the snap or the top fabric.

LIMITED WARRANTY

We warrant our product to be free from defects in material and workmanship, for the terms specified below, provided there has been normal use and proper maintenance. This warranty applies to the original purchaser only. All remedies under this warranty are limited to the repair or replacement of any item or items found by the factory to be defective within the time period specified.

If you have a warranty claim, first you must call our factory at the number below for instructions. You must retain proof of purchase and submit a copy with any items returned for warranty work. Upon completion of warranty work, if any, we will return the repaired or replaced item or items to you freight prepaid. Damage to our products caused by accidents, fire, vandalism, negligence, misinstallation, misuse, Acts of God, or by defective parts not manufactured by us, is not covered under this warranty.

THE WARRANTY TIME PERIOD IS AS FOLLOWS: ALL "SOFT GOODS" MANUFACTURED BY OUR COMPANY (USING PRIMARILY VINYL, PLASTICS, AND/OR FOAM): ONE YEAR FROM DATE OF PURCHASE.

ANY IMPLIED WARRANTIES OF MERCHANTABILITY AND/OR FITNESS FOR A PARTICULAR PURPOSE CREATED HEREBY ARE LIMITED IN DURATION TO THE SAME DURATION AND SCOPE AS THE EXPRESS WRITTEN WARRANTY. OUR COMPANY SHALL NOT BE LIABLE FOR ANY INCIDENTAL OR CONSEQUENTIAL DAMAGE.