



## Installation Instructions for 99-8300

### Toyota Multi-kit 2000-up

(see application list on page 2)

### 99-8300



#### KIT FEATURES

- ISO DIN radio provision with pocket
- Double DIN radio provision

#### KIT COMPONENTS

- A) Radio housing trim panel • B) Bracket #1 • C) Bracket #2 • D) Bracket #3 • E) Bracket #4
- F) Bracket #5 • G) Pocket • H) (4) #8 x 3/8" truss-head Phillips screws

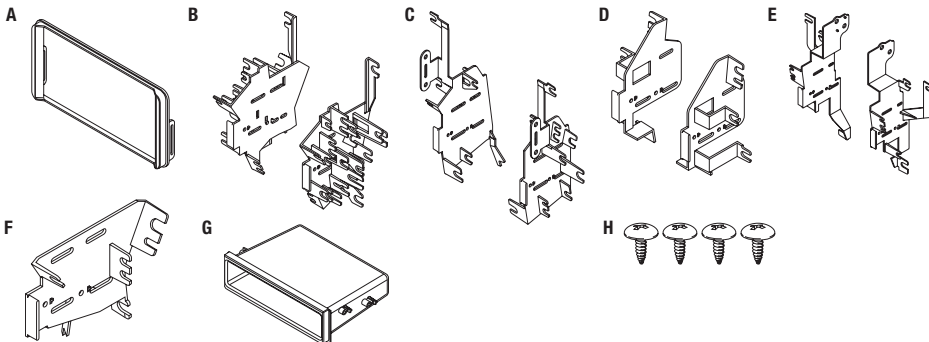

#### WIRING & ANTENNA CONNECTIONS (sold separately)

Wiring Harness: • 70-1761 harness or

TYTO-01 premium interface

Antenna Adapter: • 40-LX11 (*select models only*)

#### TOOLS REQUIRED

- Panel removal tool • Phillips screwdriver

**CAUTION:** Metra recommends disconnecting the negative battery terminal before beginning any installation. All accessories, switches, and especially air bag indicator lights must be plugged in before reconnecting the battery or cycling the ignition.

**NOTE:** Refer to the instructions included with the aftermarket radio.



99-8300

## Applications

### Pontiac

Vibe	2003-2008
------	-----------

### Scion

FR-S	2013-up
------	---------

iQ	2012-up
----	---------

tC	2005-up
----	---------

xA	2004-2006
----	-----------

xB	2004-up
----	---------

xD	2008-up
----	---------

### Subaru

BRZ	2013-up
-----	---------

### Toyota

4 Runner <i>(excluding Limited)</i>	2003-2009
-------------------------------------	-----------

Celica	2000-2005
--------	-----------

Corolla	2009-up
---------	---------

Echo	2000-2005
------	-----------

FJ	2007-up
----	---------

Highlander	2001-2007
------------	-----------

Highlander	2013
------------	------

Matrix	2003-2008
--------	-----------

MR2 Spyder	2000-2005
------------	-----------

RAV 4	2001-2005
-------	-----------

Sequoia	2003-2007
---------	-----------

Tundra	2003-2006
--------	-----------

Yaris	2012-up
-------	---------

Yaris <i>(3-door)</i>	2007-2010
-----------------------	-----------

Yaris <i>(4-door)</i>	2007-2010
-----------------------	-----------



## 99-8300 Dash Disassembly

### Toyota Yaris 2007-2010 (3-door and 4-door)

1. Unclip the bottom trim panel located underneath the A/C controls. (Figure A)
2. Unclip the two side trim panels that surround the A/C controls and radio. (Figure A)
3. Unclip the instrument trim panel surrounding the speedometer and gauges. (Figure B)
4. Unclip the radio/AC vents trim panel. (Figure B)
5. Remove (4) Phillips screws securing radio. (Figure C)
6. Unplug and remove radio.

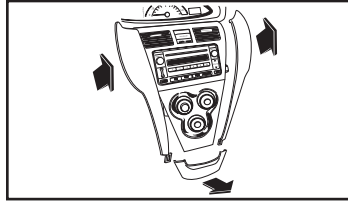

(Figure A)

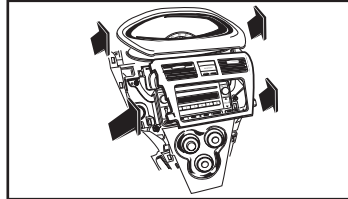

(Figure B)

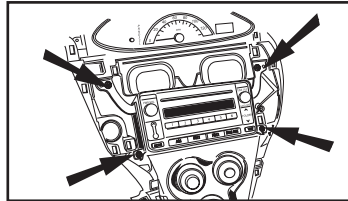

(Figure C)

### Toyota Yaris 2012-up

1. Unclip and remove entire panel including a/c vent on passenger side of dash. (Figure A)
2. Unclip and remove the panel from around the radio. (Figure B)
3. Remove four 10 mm bolts and remove factory radio. (Figure C)

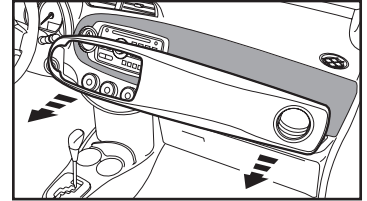

(Figure A)

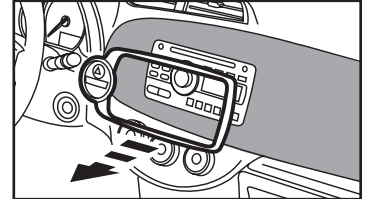

(Figure B)

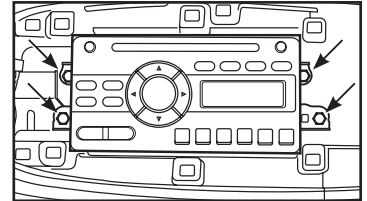



## 99-8300 Dash Disassembly

### Toyota FJ 2007-up

1. Remove two Phillips screws from bottom part of side trim panels. (Figure A)
2. Using a panel removal tool, carefully remove the side trim panels. (Figure B)
3. Remove (2) Phillips screws from radio trim panel. (Figure C)

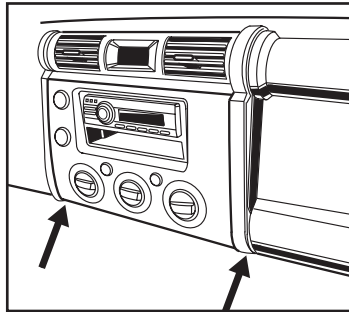

(Figure A)

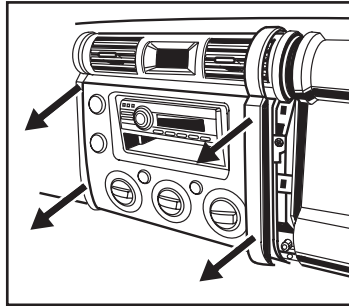

(Figure B)

4. Using panel removal tool, carefully remove radio trim panel. (Figure D)
5. Remove (4) 10 mm bolts securing the radio.
6. Unplug and remove radio.

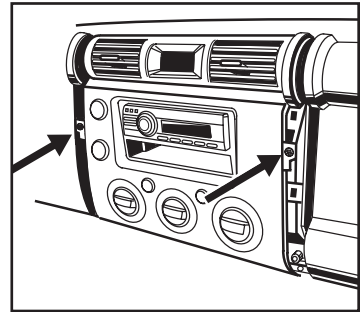

(Figure C)

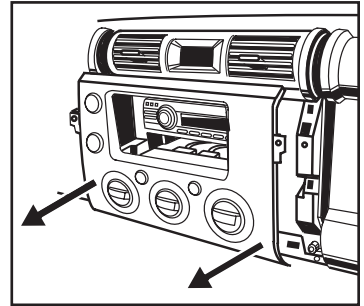

(Figure D)



## 99-8300 Dash Disassembly

### Toyota Corolla 2009-up

1. Unclip and remove the (4) side trim panels from the right and left side of the radio and a/c controls. (Figure A)
2. Unclip and remove the a/c vent panel above the factory radio. (Figure B)
3. Remove (4) 10 mm bolts securing the radio. (Figure C)
4. Remove (8) screws securing the brackets to the factory radio and remove the brackets. (Figure D)
5. Remove (4) plastic clips from the back of the factory radio.  
**Note: retain clips for re-use during kit assembly.**

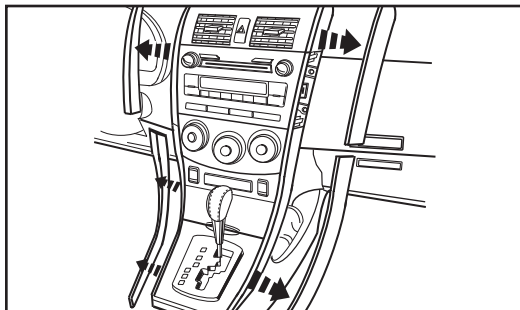

(Figure A)

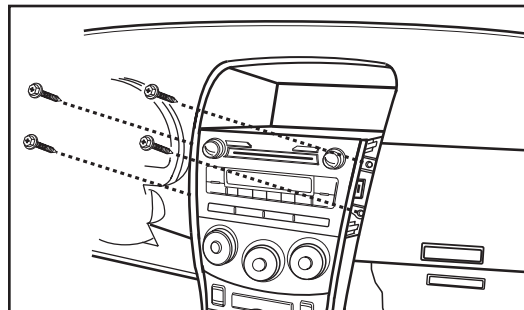

(Figure C)

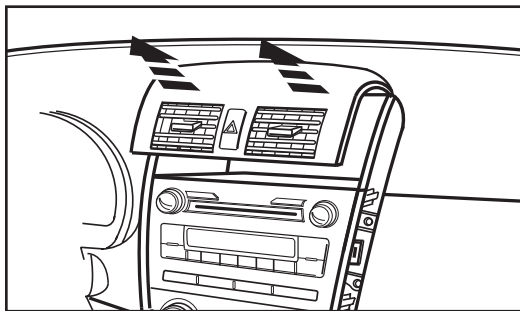

(Figure B)

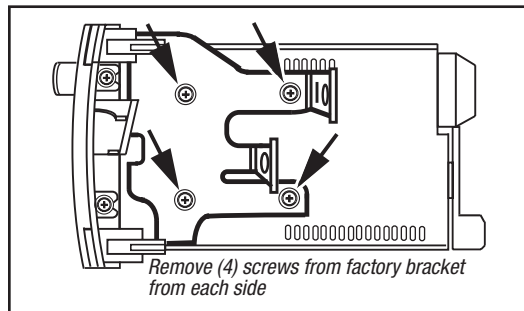

(Figure D)



## 99-8300 Dash Disassembly

### Toyota MR2 Spyder 2000-2005

1. Unsnap the lower trim piece from each side of the dash console and remove (2) Phillips screws exposed in each cavity.
2. Remove the upper trim piece from each side of the console.
3. Remove the climate control knobs and (2) Phillips screws exposed.
4. Remove the climate control trim bezel.
5. Remove the ashtray and (1) 10 mm bolt exposed.
6. Unclip the ashtray trim bezel and remove.
7. Unclip the radio trim bezel, remove (4) Phillips screws securing the unit and disconnect the wiring.

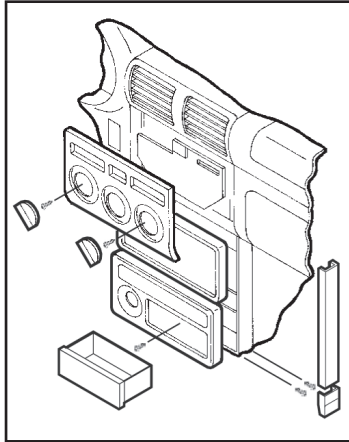

### Toyota RAV 4 2001-2005

1. Remove (4) 3/16" Allen screws from the radio trim bezel and remove the bezel.
2. Remove (4) 10 mm bolts securing the factory radio and disconnect the wiring.

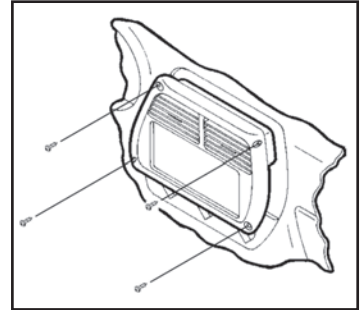

**Toyota Highlander 2001-2007**

1. Pull and remove dash panel from radio and climate controls. *Tip: There are 8 clips.* (Figure A)
2. Remove (6) 10 mm bolts from radio and climate controls assembly. (Figure B)
3. Remove assembly and disconnect the wiring.
4. Remove (8) Phillips bolts and (4) Phillips screws to separate brackets from assembly. (Figure C)

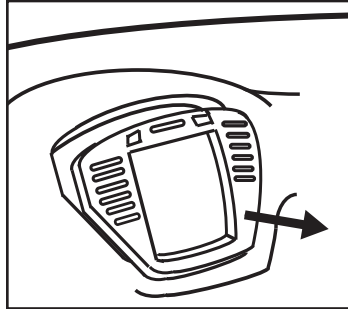
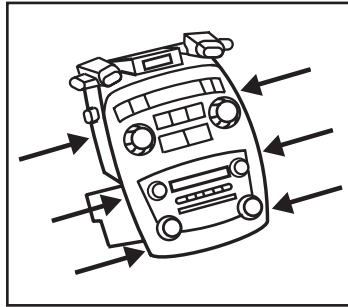
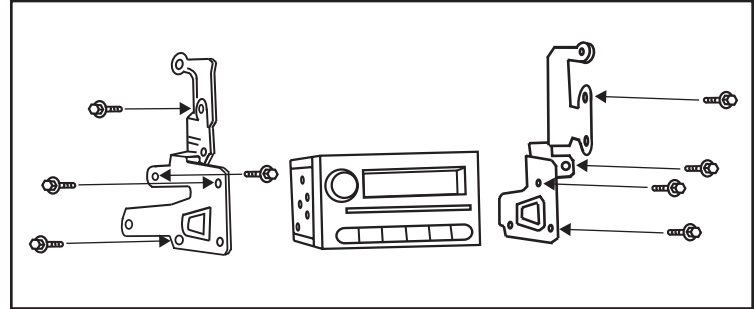
*(Figure A)**(Figure B)**(Figure C)*



## 99-8300 Dash Disassembly

### Toyota Matrix, Pontiac Vibe 2003-2008

1. Unclip the bottom edge of the radio trim panel then lift up and out to remove. (Figure A)
2. Remove (4) 10 mm bolts securing the factory radio. (Figure B)

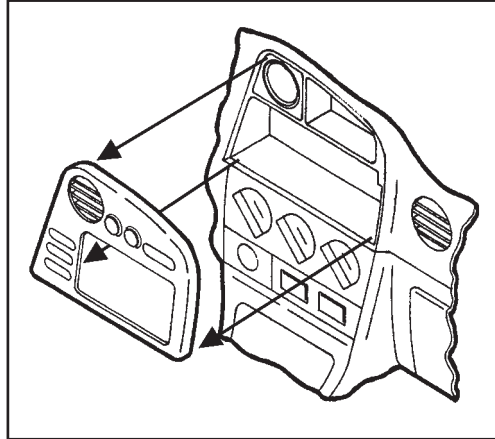

(Figure A)

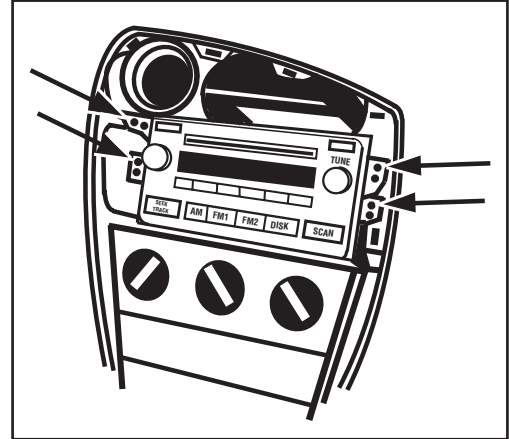

(Figure B)



**Toyota 4 Runner 2003-2009** *(excluding Limited)*

1. Unsnap and remove trim from around shifter.
2. Unsnap and remove trim covers from around center console pocket edge at front and rear of console.
3. Unsnap and remove center console cover. (Figure A)
4. Unsnap trim ring from around ignition key cylinder.
5. Remove (1) 10 mm bolt from bottom right of panel below steering column. Unsnap panel and pull away to gain access behind panel. (Figure B)
6. Remove (1) 10 mm bolt on bottom left of center panel behind panel below steering column. (Figure B)

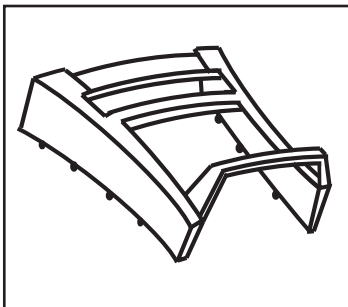
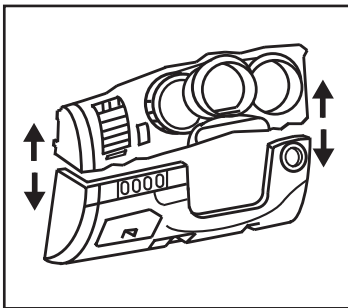
*(Figure A)**(Figure B)*

7. Remove (1) 10 mm bolt beneath climate control behind pocket door. Unsnap and remove climate control. (Figure C)
8. Remove (2) 10 mm bolts beneath radio behind climate controls.
9. Unsnap and remove entire center panel around radio. (Figure D)
10. Remove (2) 10 mm bolts securing radio to remove.

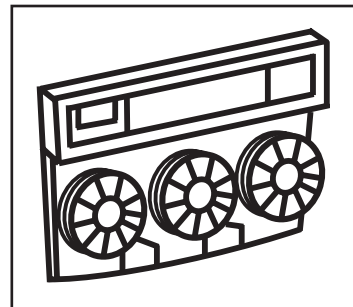
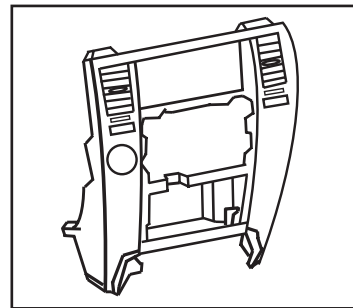
*(Figure C)**(Figure D)*

## Toyota Celica 2000-2005

1. Unclip and remove the gear shifter trim bezel and remove (2) Phillips screws exposed below the climate controls.
2. Pull off climate control knobs and remove (2) Phillips screws exposed.
3. Unclip the climate control/factory radio trim bezel and remove. Remove (4) 10 mm screws securing the factory radio and disconnect the wiring.

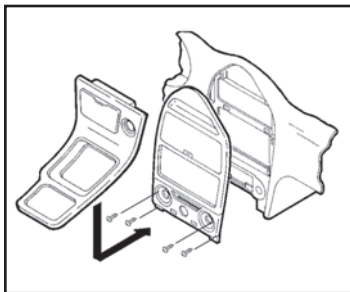

## Toyota Echo 2000-2005

1. Remove the climate control knobs and (2) Phillips screws exposed.
2. Unclip and remove the climate control trim bezel.
3. Depress the side clips securing the climate control panel and move the panel to access (2) Phillips screws from the top of the factory radio brackets.
4. Remove the ashtray.
5. Unclip and remove the radio trim bezel.
6. Remove (2) Phillips screws from the bottom of the radio brackets and disconnect the wiring.

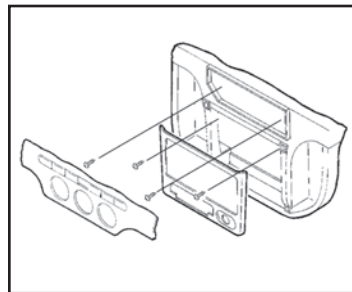



## 99-8300 Dash Disassembly

### Toyota Sequoia 2001-2007

1. Position vents facing upward and remove (1) Phillips screw from each A/C vent. (Figure A)
2. Unclip and remove entire radio trim panel including climate controls. (Figure B)
3. Remove (4) 10 mm bolts to remove radio. (Figure C)

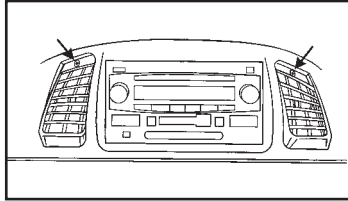

(Figure A)

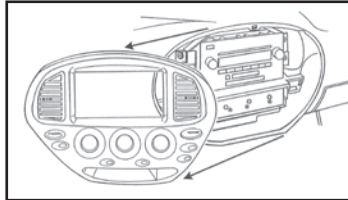

(Figure B)

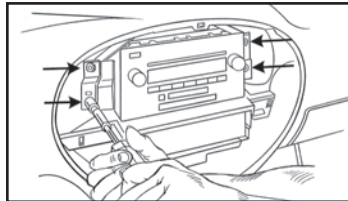

(Figure C)

### Toyota Tundra 2003-2006

1. Remove the (3) climate control knobs by pulling straight outward. (Figure A)
2. Remove (3) Phillips screws from behind knobs. (Figure A)
3. Position vents facing upward and remove (1) Phillips screw from each A/C vent. (Figure B)
4. Unclip and remove entire radio trim panel including climate controls. (Figure C)
5. Remove (4) 10 mm bolts to remove radio. (Figure D)

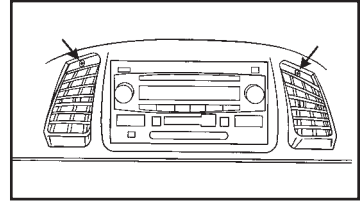

(Figure B)

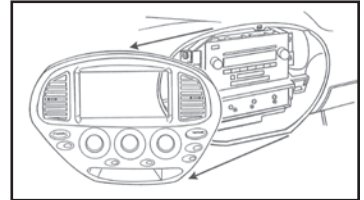

(Figure C)

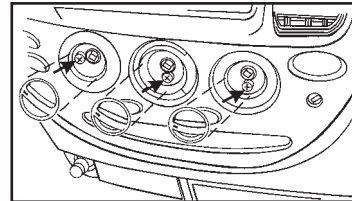

(Figure A)

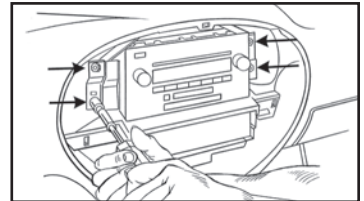

(Figure D)



## 99-8300 Dash Disassembly

### Toyota Highlander 2013

1. Unclip and remove the A/C vent panel. (Figure A)
2. Unclip and remove the trim panel containing the A/C control and pocket. (Figure B)

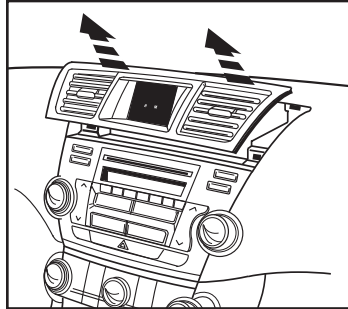

(Figure A)

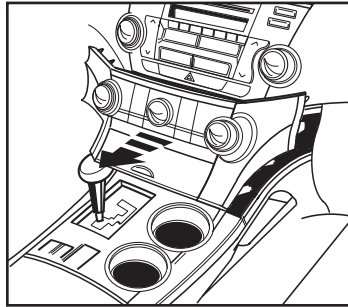

(Figure B)

3. Remove (4) 10 mm bolts securing the radio assembly. (Figure C)
4. Remove the (4) Phillips screws securing the clock/display then remove the clock/display from the radio assembly. (Figure D)

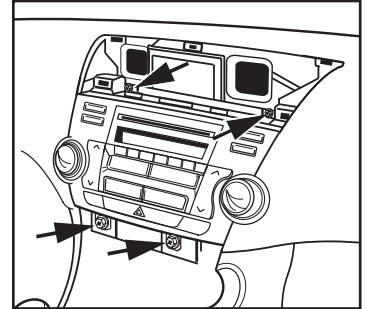

(Figure C)

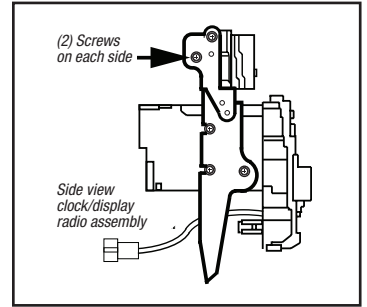

(Figure D)



## 99-8300 Dash Disassembly

### Scion FR-S 2013-up, Subaru BRZ 2013-up

1. Unclip and remove the panel from around the radio. (Figure A)
2. Remove four 10 mm bolts, then remove the factory radio. (Figure B)

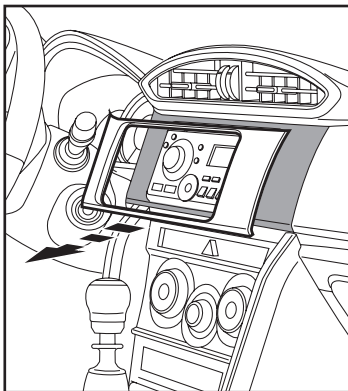

(Figure A)

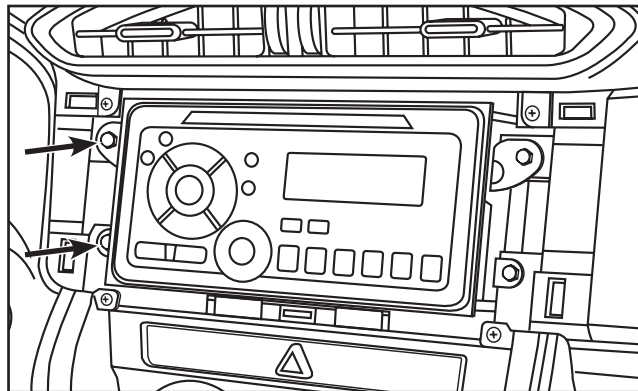

(Figure B)



## 99-8300 Dash Disassembly

### Scion xA 2004-2006

1. Pull outward on the (3) climate control knobs and remove. (Figure A)
2. Remove (2) Phillips screws from behind the outer two climate knobs. (Figure B)
3. Unsnap and remove the trim pieces on each side of the climate control/ashtray/pocket assembly. (Figure C)

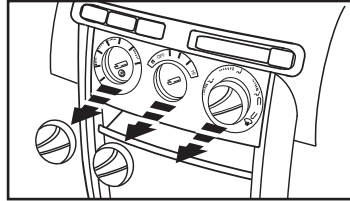

(Figure A)

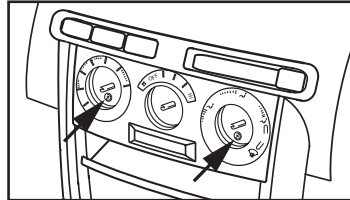

(Figure B)

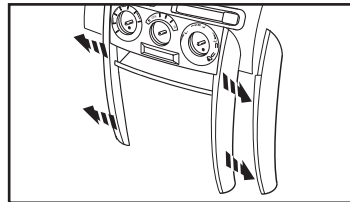

(Figure C)

4. Remove (2) Phillips screws from the bottom of the climate control/radio trim panel and unsnap and remove the entire panel. (Figure D)
5. Remove (4) 10 mm bolts securing the radio. Unplug and remove the radio. (Figure E)

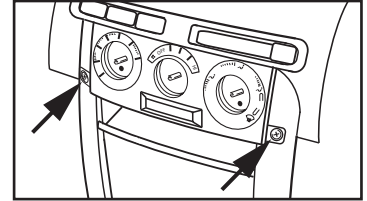

(Figure D)

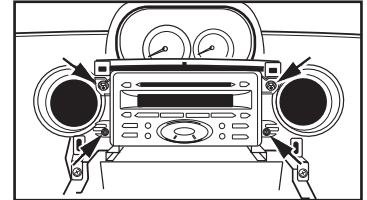

(Figure E)



## 99-8300 Dash Disassembly

### Scion xB 2004-2007

1. Pull outward on the (3) climate control knobs and remove. (Figure A)
2. Remove (2) Phillips screws from behind the outer (2) knobs. (Figure B)
3. Unsnap and remove the entire panel surrounding the climate controls and the radio. (Figure C)
4. Remove (4) 10 mm bolts securing the radio. Unplug and remove the radio.

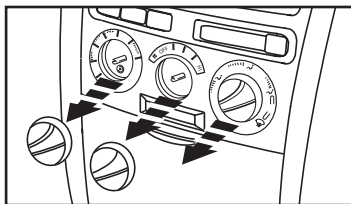

(Figure A)

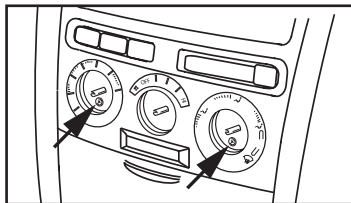

(Figure B)

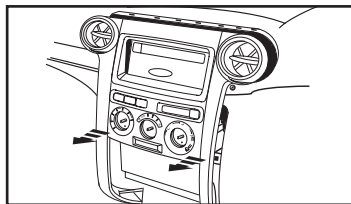

(Figure C)

### Scion xB 2008-up

1. Unclip and remove the trim panel around the radio including the A/C vents. (Figure A)
2. Unclip and remove the trim panel at the bottom edge of the dash cavity. (Figure A)
3. Remove (4) 10 mm bolts securing the radio. Unplug and remove the radio. (Figure B)

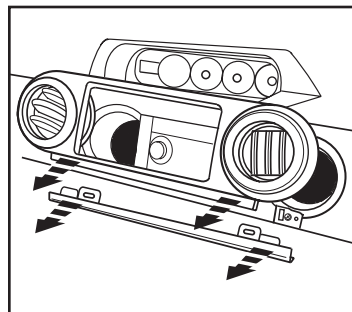

(Figure A)

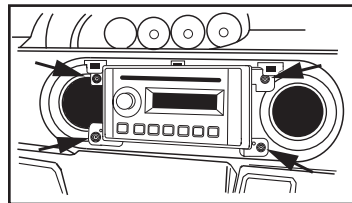

(Figure B)



## 99-8300 Dash Disassembly

### Scion tC 2005-2010

1. Unsnap trim from around shifter, not necessary to completely remove. (Figure A)
2. Unsnap and remove panel from around radio, including climate controls and radio door. (Figure B)
3. Remove (2) 10 mm nuts from the top mounting locations and (2) Phillips screws from the bottom mounting locations to remove the radio. (Figure C)

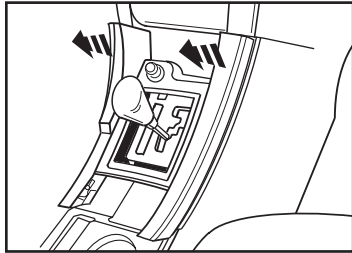

(Figure A)

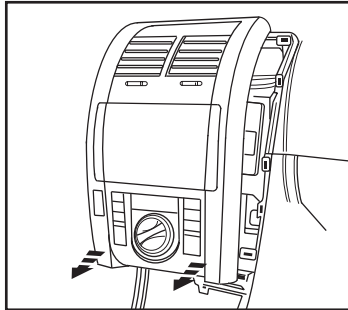

(Figure B)

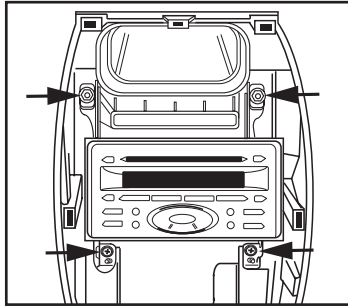

(Figure C)

### Scion tC 2011-up

1. Unsnap and remove the panel from around the radio. (Figure A)
2. Remove four 10 mm bolts and remove factory radio. (Figure B)

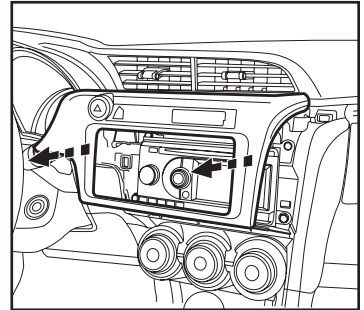

(Figure A)

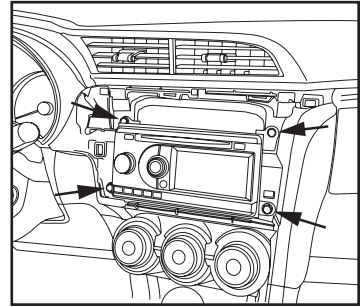

(Figure B)





## 99-8300 Kit Assembly

### Scion xD 2008-up

1. Unclip radio trim panel. Unplug and remove panel. (Figure A)
2. Remove (4) Phillips screws securing the radio. Unplug and remove radio. (Figure B)

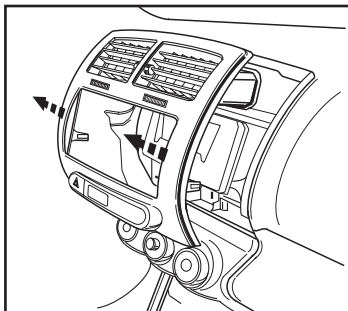

(Figure A)

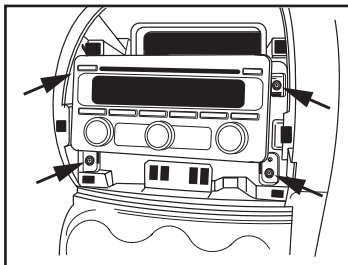

(Figure B)

### Scion iQ 2012-up

1. Unclip and remove the climate control panel. (Figure A)
2. Unclip and remove the panel from around the radio. (Figure B)
3. Remove four 10 mm bolts and remove factory radio. (Figure C)

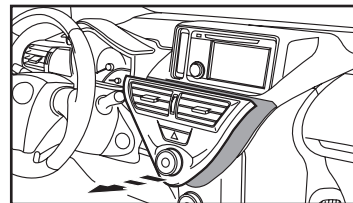

(Figure A)

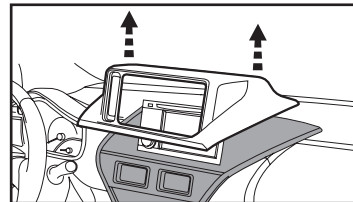

(Figure B)

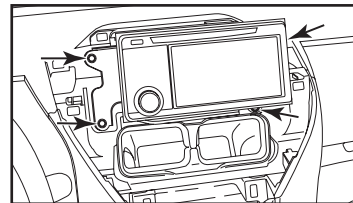

(Figure C)



## 99-8300 Kit Assembly

### Bracket #1 tab layout (Drivers side shown)

Bracket #	Tab	Vehicle
1	A	Scion xB 2008-up
1	B	Scion FR-S, Subaru BRZ 2013-up
1	C	Scion xB 2004-2007
1	D	Scion xA 2004-2006
1	E	Toyota Yaris 2012-up
1	F	Scion tC 2011-up
1	G	Scion tC 2005-2010
1	I	Toyota FJ 2007-up
1	J	Toyota Corolla 2009-up
1	K	Toyota MR2 Spyder 2000-2005
1	L	Toyota RAV 4 2001-2005

**Note:** It may be necessary to remove all unneeded tabs from the brackets for certain applications. Depending on the application it may also be necessary to trim the entire bracket as close as possible to the radio mounting locations on the brackets.

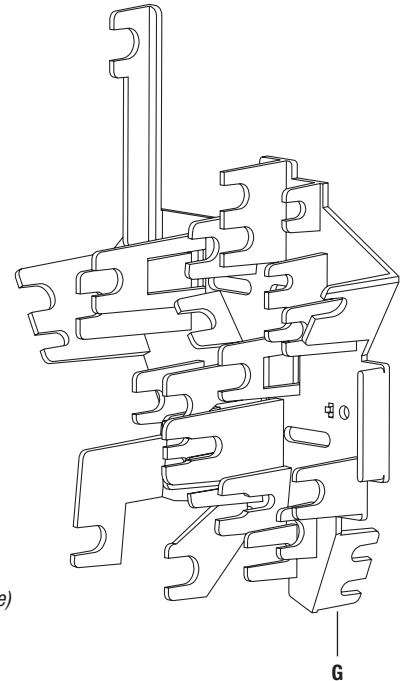
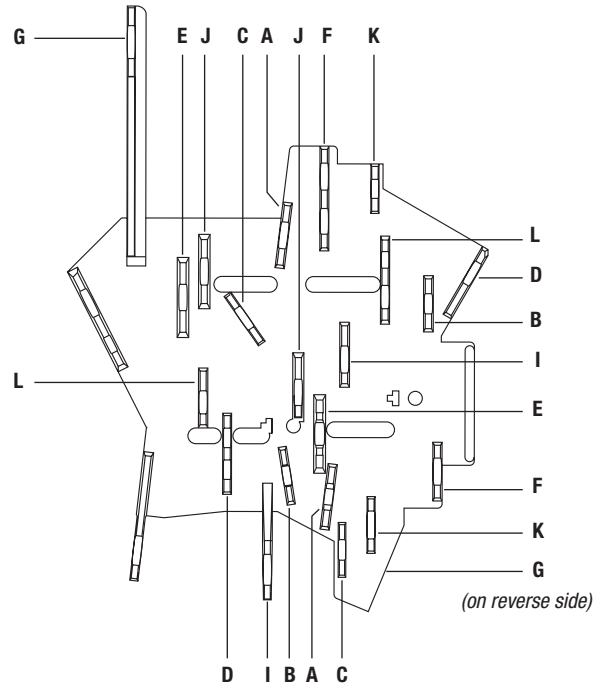



## 99-8300 Kit Assembly

### Bracket #2 tab layout

Bracket #	Tab	Vehicle
2	M	Toyota Highlander 2001-2007
2	O	Toyota 4 Runner (excluding Limited) 2003-2009
2	P	Scion xD 2008-up
2	Q	Toyota Celica 2000-2005

**Note:** It may be necessary to remove all unneeded tabs from the brackets for certain applications. Depending on the application it may also be necessary to trim the entire bracket as close as possible to the radio mounting locations on the brackets.

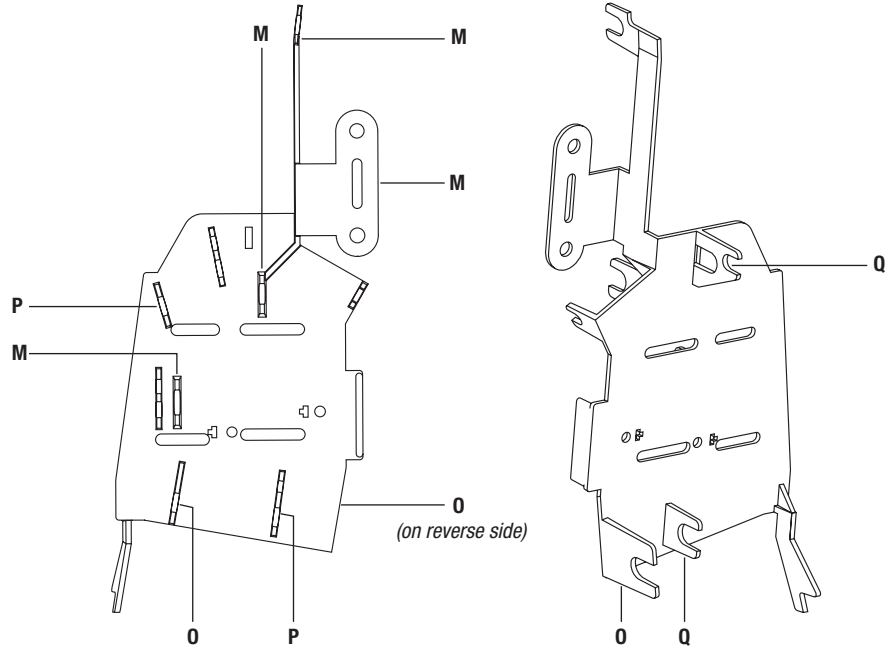



## 99-8300 Kit Assembly

### Bracket #3 tab layout

Bracket #	Tab	Vehicle
3	S	Toyota Yaris (3-door) 2007-2010
3	T	Toyota Sequoia 2003-2007
3	T	Toyota Tundra 2003-2006

**Note:** It may be necessary to remove all unneeded tabs from the brackets for certain applications. Depending on the application it may also be necessary to trim the entire bracket as close as possible to the radio mounting locations on the brackets.

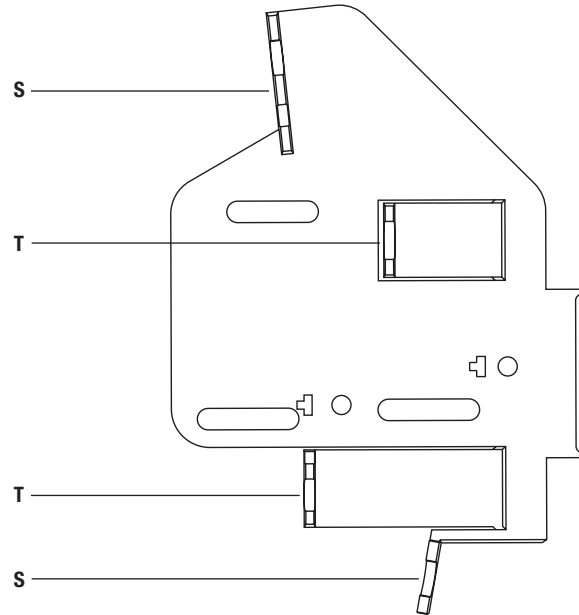



## 99-8300 Kit Assembly

### Bracket #4 tab layout

Bracket #	Tab	Vehicle
4	U	Toyota Yaris (4-door) 2007-2010
4	V	Toyota Highlander 2013

**Note:** It may be necessary to remove all unneeded tabs from the brackets for certain applications. Depending on the application it may also be necessary to trim the entire bracket as close as possible to the radio mounting locations on the brackets.

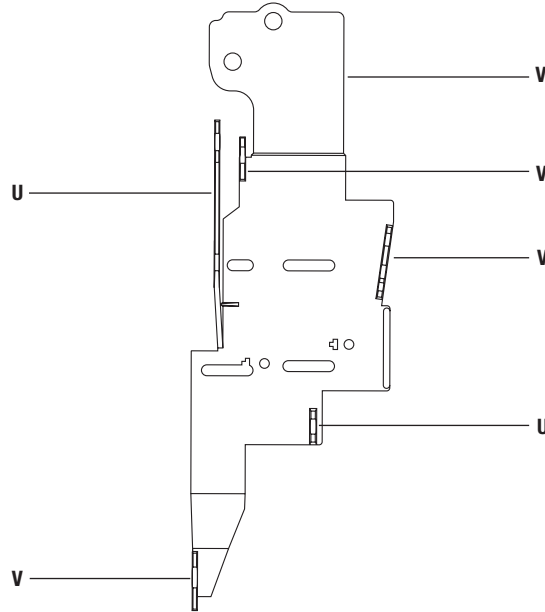

**Brackets #1 and #5 tab layout** *(Scion iQ, 2012-up)*

Bracket #	Tab	Vehicle
1 <i>(left side bracket only)</i>	H	Scion iQ 2012-up
5	H	

*Note: It may be necessary to remove all unneeded tabs from the brackets for certain applications. Depending on the application it may also be necessary to trim the entire bracket as close as possible to the radio mounting locations on the brackets.*

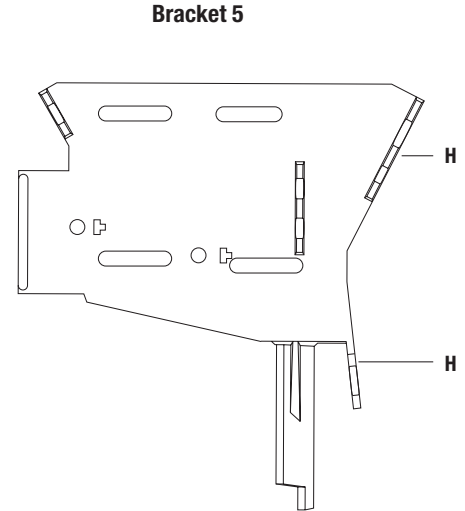
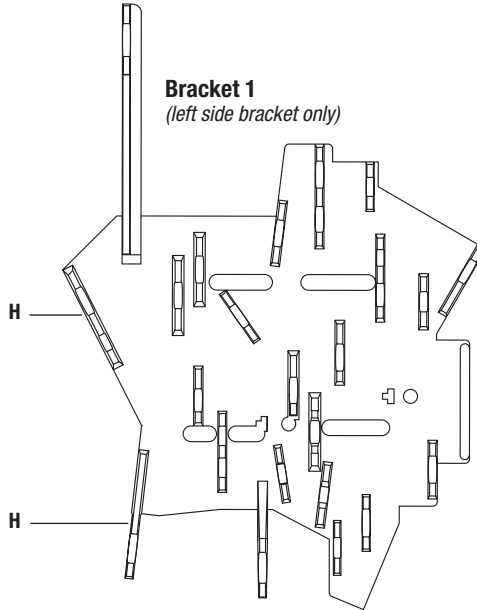



## 99-8300 Kit Assembly

### Brackets #2 and #5 tab layout *(Toyota Matrix, Pontiac Vibe, 2003-2008)*

Bracket #	Tab	Vehicle
2 <i>(left side bracket only)</i>	N	Toyota Matrix, Pontiac Vibe 2003-2008
5	N	

**Note:** *It may be necessary to remove all unneeded tabs from the brackets for certain applications. Depending on the application it may also be necessary to trim the entire bracket as close as possible to the radio mounting locations on the brackets.*

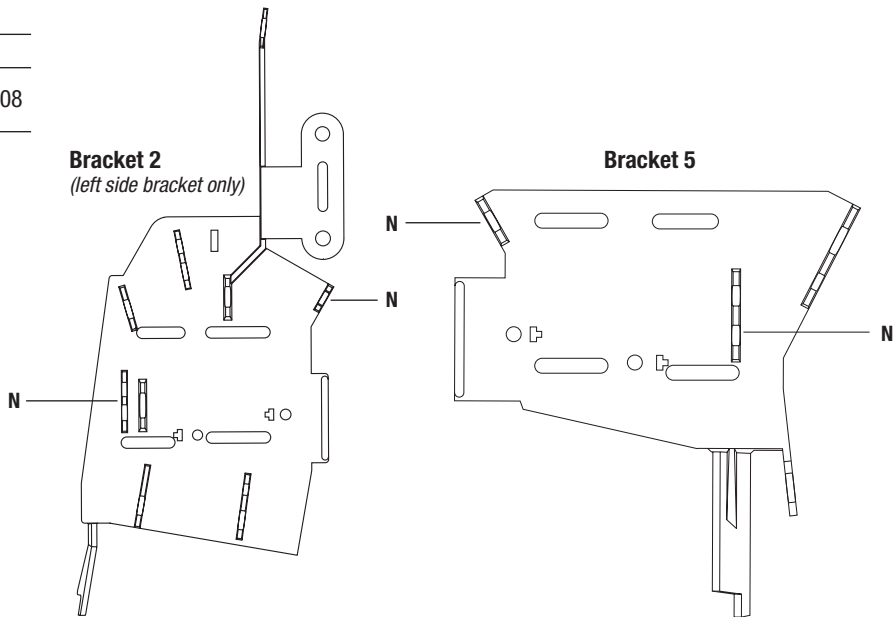



## 99-8300 Kit Assembly

### Brackets #2 and #5 tab layout *(Toyota Echo, 2000-2005)*

Bracket #	Tab	Vehicle
2 <i>(left side bracket only)</i>	R	Toyota Echo 2000-2005
5	R	

**Note:** *It may be necessary to remove all unneeded tabs from the brackets for certain applications. Depending on the application it may also be necessary to trim the entire bracket as close as possible to the radio mounting locations on the brackets.*

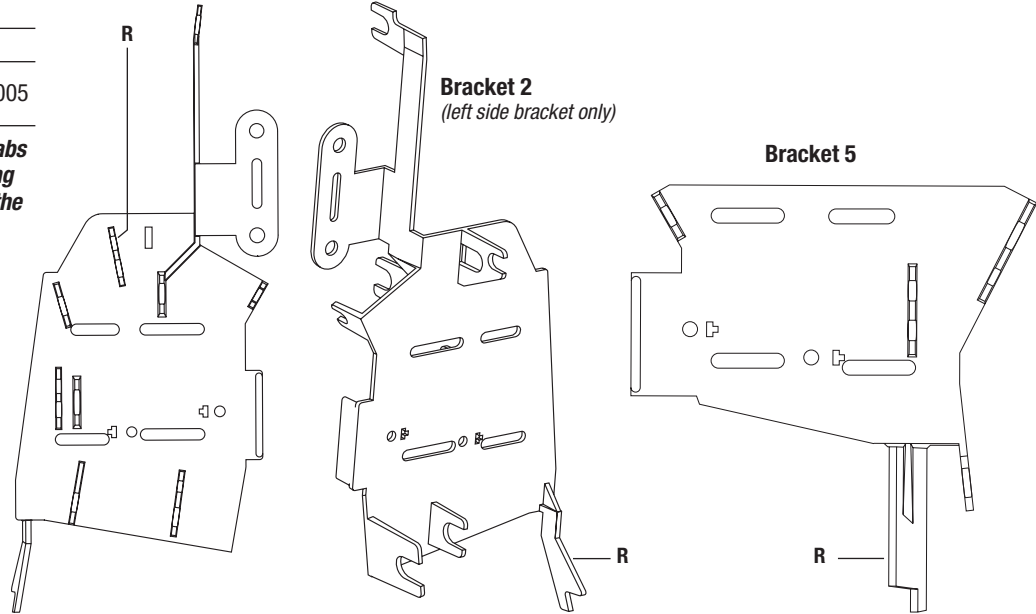





99-8300

## Kit Assembly

### ISO DIN radio provision

1. Attach your corresponding bracket to the radio housing trim panel. (*Bracket #3 shown*) (Figure A)
2. Mount the pocket to the bracket/panel assembly with the (4) #8 x 3/8" Phillips screws supplied. (Figure B)
3. Slide the radio into the assembly and secure with screws supplied with the radio. (Figure C)
4. Locate the factory wiring harness and antenna plug in the dash. Metra recommends using the proper mating adapters from Metra and/or AXCESS.
5. Mount the new radio assembly into the dash and reassemble dash in reverse order of disassembly.

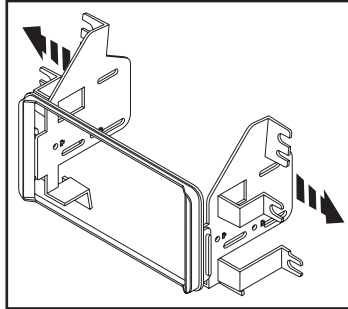

(Figure A)

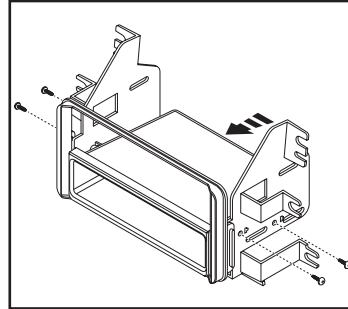

(Figure B)

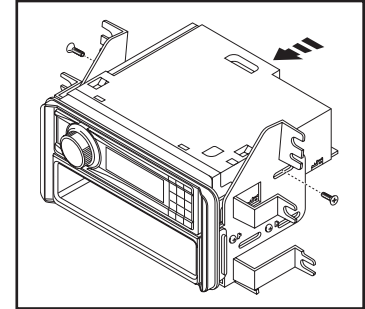

(Figure C)



99-8300

## Kit Assembly

### Double DIN radio provision

1. Attach your corresponding bracket to the radio housing trim panel. (*Bracket #3 shown*) (Figure A)
2. Slide the radio into the assembly and secure with screws supplied with the radio. (Figure B)
3. Locate the factory wiring harness and antenna plug in the dash. Metra recommends using the proper mating adapters from Metra and/or AXXESS.
4. Mount the new radio assembly into the dash and reassemble dash in reverse order of disassembly.

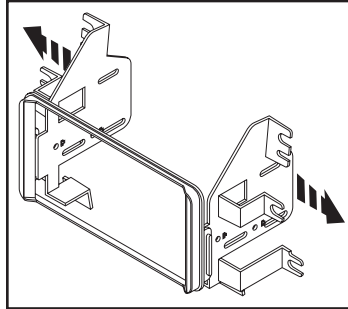

(Figure A)

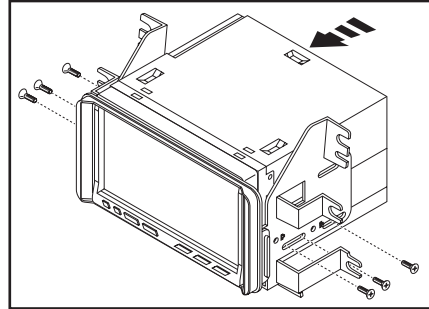

(Figure B)