



Installation instructions for part 99-8250

Toyota Sienna 2015-up 99-8250

KIT FEATURES

- ISO DIN radio provision with pocket



KIT COMPONENTS

- A) [Radio trim panel](#) • B) Radio brackets • C) Pocket • D) (8) #8 x 3/8" Phillips screws

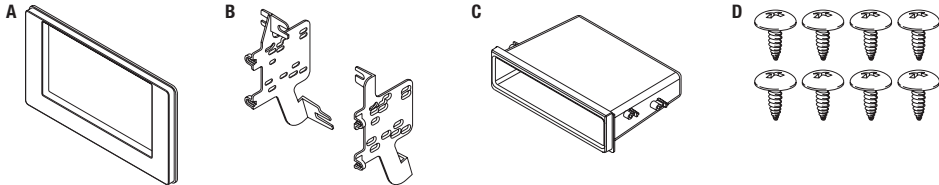

WIRING & ANTENNA CONNECTIONS (sold separately)

Wiring Harness: • 70-1761 • TYTO-01

Antenna Adapter: • 40-LX11

TOOLS REQUIRED

- Panel removal tool • Phillips screwdriver
- Socket wrench

CAUTION: Metra recommends disconnecting the negative battery terminal before beginning any installation, unless the vehicle manufacturer recommends against so. Please check with your local Dealership for more information. All accessories, switches, climate controls panels, and especially air bag indicator lights must be connected before reconnecting the battery or cycling the ignition. Also, do not remove the factory radio with the key in the on position, or the vehicle running. It would be best to remove the key from the ignition and then wait a few seconds before removing the factory radio.

Dash Disassembly

1. Unscrew the shift lever knob.
(Figure A)
2. Unsnap and remove the top dash trim panel (across instrument cluster and radio). (Figure B)

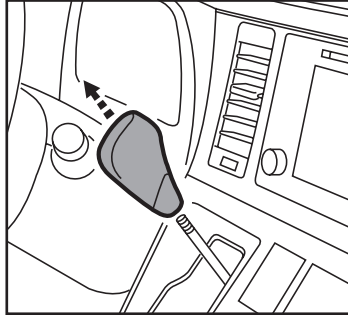

(Figure A)

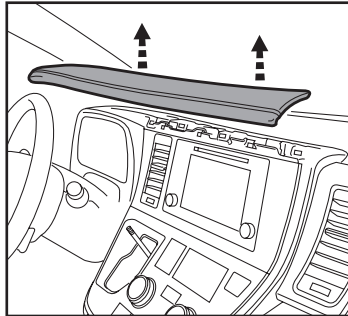

(Figure B)

3. Unsnap the instrument panel trim. Not necessary to completely remove. (Figure C)
4. Unsnap the radio trim panel including the climate controls. (Figure D)
5. Remove (4) 10 mm screws to remove the radio

Continue to kit assembly

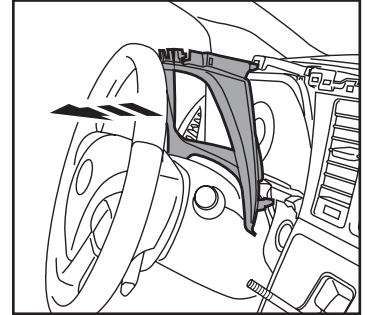

(Figure C)

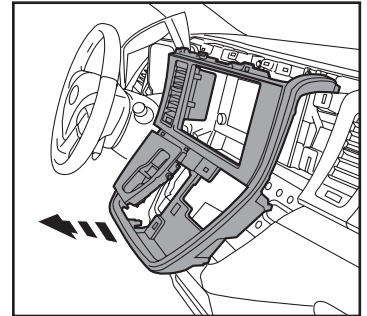

(Figure D)

Kit Assembly

ISO DIN radio provision with pocket

1. Attach the radio brackets to the radio trim panel using (4) #8 x 3/8" Phillips screws supplied. (Figure A)
2. Attach the pocket to the bracket assembly using the (4) #8 x 3/8" Phillips screws supplied. (Figure B)
3. Remove the metal DIN sleeve and trim ring from the aftermarket radio.
4. Slide the radio into the completed assembly, and then secure it to the assembly using screws supplied with the radio. (Figure C)
5. Locate the factory wiring harness and antenna connector in the dash, and complete all necessary connections to the radio. Metra recommends using the proper mating adapter from Metra and/or AXXESS. Re-connect the negative battery terminal and test the radio for proper operation.
6. Reassemble the dash in reverse order of disassembly.

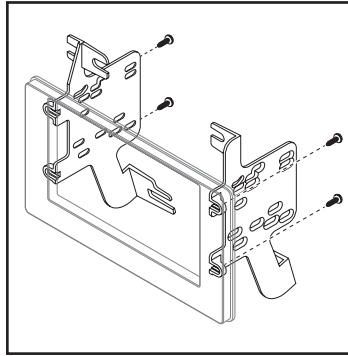

(Figure A)

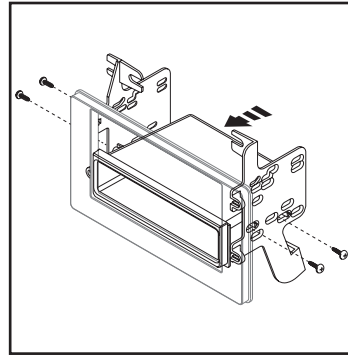

(Figure B)

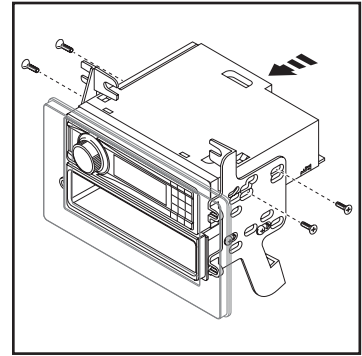

(Figure C)