

# MasterCraft

SAFETY

2021 CATALOG



RECREATIONAL SEATS	
BAJA RS	4
RUBICON	6
NOMAD	8
SPORTSMAN	9
ORIGINAL	12
CAMBER	13
UTV SEATS	
S2/4	16
PWR SPORT	18
RACE SEATS	
3GR & 3G4	22
PROSEAT & PRD4	24
IMPACT HSI	26
IMPACT GENESYS	28
BENCHES & SLIP COVERS	
FACTORY FIT SLIP COVERS	32
RUBICON BENCH	34
ORIGINAL BENCH	35

ACCESSORIES	
MOUNTING BRACKETS	37
SEAT ADD-ON OPTIONS	38
MISC ACCESSORIES	39
RESTRAINTS & STRAPS	
GRAB HANDLES	40
TIE-DOWNS	41
RESTRAINTS	42
NETS & LIMIT STRAPS	44
STORAGE	
TOOL BAGS & DRIVER GEAR BAGS	46
INFORMATION	
SEAT SPECS	48
LOCATIONS & WARRANTY	49



### MASTERCRAFT: THE LEADER IN OFF-ROAD SEATING SINCE 1970

All MasterCraft seats are expertly constructed from mandrel bent and laser-notched .065 three-quarter inch tubing to exacting Mil-spec standards and feature either a flat strap or four-tab mount fully integrated into the frame. By incorporating the frame mounting straps, MasterCraft strengthened the overall integrity of the structure by ensuring that your seat can handle any abuse from weekend wheeling to extreme Baja racing. Finished with a high-resiliency fatigue fighting foam and fire retardant UV-treated upholstery, your MasterCraft seat has been extensively tested and validated to comply with all applicable seat criterion of the Federal Motor Vehicle Safety Standard.

Don't settle for inferior construction – only a genuine MasterCraft seat offers this level of craftsmanship!

While comfort and safety on the trail are important, MasterCraft has also serves a market where impact absorption and energy attenuation create the line between life and death. As devoted patriots, the team at MasterCraft are exceptionally proud of our work with the US Armed Forces.

Developing and testing seating systems to exceed requirements outlined by stringent military standards is never an easy task. To that end, MasterCraft accepted the challenge and delivered a line of energy-mitigating seats that perform remarkably well in a conflicting environment. MasterCraft's Made in the U.S.A. defense seating and restraint systems have been used in US military combat vehicles such as the MRAP and LSAC for nearly a decade and have a proven track-record.

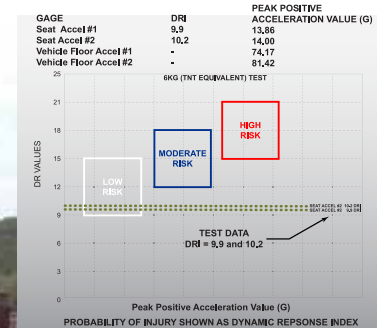

**BLAST TESTED**

Independent tests have shown MasterCraft Safety's line of energy-attenuating defense seating provides an 84% reduction in force from a 50 "G" load live fire (blast) event; a force equal to that of 6kgs of explosive mass as outlined in the NATO Stanag 4569 2A standard. These are exactly the types of impacts that IEDs inflict on combat vehicles and why MasterCraft has devoted tremendous resources and technology towards developing safety solutions for our men and women serving overseas.

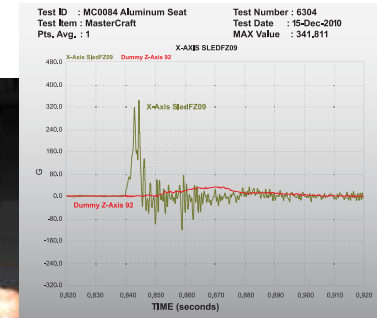

**SLED TESTED**

Independent tests indicated that MasterCraft Safety's line of defense seating provided remarkable and repeatable energy-attenuation during +Z axis impacts. The above graph indicates a massive 342G +Z-axis hit to the seat base resulting in only 34Gs of energy reaching the 50th percentile Hybrid III Anthropomorphic Test Device's instrumented pelvis. This test is representative of the extreme forces experienced by combat vehicles in conflict areas and demonstrative of MasterCraft's ability to mitigate enormous impact energy.

## ABOUT MASTERCRAFT

As leading pioneers in the recreational off-road and racing market since 1970, MasterCraft Safety, together with our sister brand, Impact Racing, have been a mainstay and trusted name brand for nearly two generations of off-road and motorsports enthusiasts. The recipe to our success is simple; we were the first and we are the best.

MasterCraft is the first company to offer a suspension seat specifically designed for the off-road racing market. This seemingly simple creation provided competitors with comfort and much-needed energy attenuation lacking on the early beam suspension racecars. It didn't take long for the recreational off-road market to demand the same level of comfort and fatigue-fighting ergonomics, thus the Rubicon® and MasterCraft Baja RS® were born. The launch of these two seats for the everyday street-to-trail recreational market forged a new level of comfort and made MasterCraft a brand that has been often imitated, but never duplicated.

MasterCraft has since expanded its product lines to include occupant restraints rated to both the SFI 16.1 and 16.5 standard, as well as SFI 27.1 rated window nets. MasterCraft also offers a full line of tie downs and ruggedized storage solutions to keep your tools and other necessities safely nestled in your weekend trail rig and your race vehicle securely strapped onto the trailer. Be sure to check out our full-line up of products on the following pages as we do offer many more safety and convenience essentials. If you have any questions, feel free to contact customer support.



**BAJA RS® \$499.95**  
**PREMIUM RECLINING SUSPENSION SEAT**

The first reclining suspension seat for off-road enthusiasts, the MasterCraft Baja RS® offers comfort, containment, safety and fatigue-fighting ergonomics perfect for exploring Moab or taking on your grueling everyday commute. Designed with both form and function in mind, MasterCraft's Baja RS® seat features a mid-rise side bolster for ease of ingress and egress while also providing superior containment; even during the most spirited adventures. Covered in a durable yet comfortable UV-resistant Marquesa fabric, the Baja RS® also offers superior lumbar support with our proprietary high-resiliency foam offering the ultimate in energy attenuation and fatigue-fighting comfort. The machined billet lever and 9-position reclining mechanism provide years of trouble-free use while the integrated seat belt slots and belt loops provide harness guides ensuring your five-point belts stay in place. With available "creature comfort" options such as seat heaters, lumbar support, seat pockets and Camelbak™ pouches, the MasterCraft Baja RS® provides the ultimate seat, balancing everyday practicality with features specifically designed for off-road use. Additionally, MasterCraft seats are sled and drop-tested and exceeds Federal Motor Vehicle Safety Standard (FMVSS) requirements. The Baja RS® shares the same flexibility in mounting as our popular Rubicon® series seat and is the perfect addition to your Jeep® JK, TJ, CJ and YJ, as well as Ford Bronco, Toyota Tacoma, Toyota Land Cruiser, and more. Available in five standard color combinations and five Dirt Sport color combos, the MasterCraft Baja RS® will enhance both the comfort and interior of your vehicle!

- 9-Position Reclining Seat from Forward Tilt to Full Recline
- Left (Driver) or Right (Passenger) Recliner Mechanism Location
- High Resiliency Foam for Superior Energy Attenuation & Comfort
- Machined Billet Lever and Heavy Duty Reclining Mechanism for Improved Performance
- Durable yet Comfortable UV-Treated Marquesa Fabric available in 10 Color Styles
- 5-Point Seat Belt Slots (with additional seat belt loops to secure harnesses in place)
- Many Available Options such as Seat Heaters, Lumbar Support, Seat Pockets and More
- Tested and Validated to Comply with Applicable FMVSS
- Direct Bolt-In Application for Most Jeep® CJ-5s, all Jeep® CJ-7 & YJs
- Hip Containment: 6.5-inches

**MADE IN THE USA** 



**RECLINER:**  
 9-Position Recliner  
 From Forward Tilt  
 to Full Recline

TACTICAL COVER	BLACK	OD GREEN	TAN
RECLINER LEVER LEFT - FIXED HEADREST	516104	516101	516108
RECLINER LEVER RIGHT - FIXED HEADREST	518104	518101	518109

BRS COVER	BLACK w/RED	BLACK w/BLUE	ALL BLACK	SMOKE w/GRAY	TAN w/BROWN
RECLINER LEVER LEFT - FIXED HEADREST	504022	504023	504024	504027	504028
RECLINER LEVER RIGHT - FIXED HEADREST	506022	506023	506024	506027	506028
RECLINER LEVER LEFT - ADJUSTABLE HEADREST <b>+\$125</b>	512022	512023	512024	512027	512028
RECLINER LEVER RIGHT - ADJUSTABLE HEADREST <b>+\$125</b>	514022	514023	514024	514027	514028

DIRTSPOUT COVER <b>+\$100</b>	BLACK w/RED	BLACK w/BLUE	ALL BLACK	SMOKE w/GRAY	TAN w/BROWN
RECLINER LEVER LEFT - FIXED HEADREST	504122	504123	504124	504127	504128
RECLINER LEVER RIGHT - FIXED HEADREST	506122	506123	506124	506127	506128
RECLINER LEVER LEFT - ADJUSTABLE HEADREST <b>+\$125</b>	512122	512123	512124	512127	512128
RECLINER LEVER RIGHT - ADJUSTABLE HEADREST <b>+\$125</b>	514122	514123	514124	514127	514128

*\*The Dirt Sport Cover is designed to add styling while reinforcing areas of the seat that experience a little more wear and tear. The Dirt Sport insets feature our durable reinforced vinyl with a carbon-fiber look that meets both form and*

function.	CUSTOM ADD-ON OPTIONS
ADD PASSENGER'S SIDE - LUMBAR LEFT	600001
ADD DRIVER'S SIDE - LUMBAR RIGHT	600002
ADD ELECTRONIC SEAT HEATER (Installed)	600006
ADD REAR SEAT POCKET	600008
ADD CAMELBAK POCKET	600060
ADD CAMELBAK SET (Pocket, Reservoir & Tube included)	600061

**NEW PRODUCT**



**TACTICAL COVER:** Black w/Black Center and Black Sides | **TACTICAL COVER:** OD Green w/Green Center and Green Sides | **TACTICAL COVER:** Tan w/Tan Center and Tan Sides | **BRS COVER:** Black w/Black Center and Red Sides | **BRS COVER:** Black w/Black Center and Blue Sides | **BRS COVER:** Black w/Black Center and Black Sides | **BRS COVER:** Smoke w/Black Center and Gray Sides | **BRS COVER:** Desert Tan w/Black Center and Brown Haze Sides



**DIRTSPOUT COVER:** Black w/Red Center and Red Sides | **DIRTSPOUT COVER:** Black w/Blue Center and Blue Sides | **DIRTSPOUT COVER:** Black w/Black Center and Black Sides | **DIRTSPOUT COVER:** Smoke w/Gray Center and Gray Sides | **DIRTSPOUT COVER:** Desert Tan w/Brown Haze Center and Brown Haze Sides



**ADJUSTABLE HEADREST:** Adjustable Headrest Shown on the All Black DirtSport Cover.

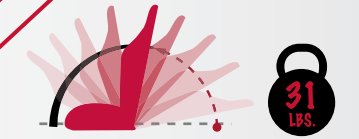

\* For Full Dimensions See Pg. 48

**RUBICON® \$329.95**  
**PREMIUM FIXED-BACK SUSPENSION SEAT**

The MasterCraft Safety Rubicon® is a fixed-back seat and is the ideal choice for off-roaders wanting the benefits and comfort of a true suspension seat while not requiring a reclining function. The Rubicon® features the same high-quality precision craftsmanship that has made MasterCraft a trusted household name for Jeep® and off-road enthusiasts worldwide. Featuring a three-quarter rise bolster, the Rubicon® offers 6.5-inches of hip containment and 5.5-inches of shoulder containment keeping you safely nestled into your seat, even while maneuvering the most challenging obstacle or conquering the seat's namesake; the iconic "Rubicon Trail."

MasterCraft's Rubicon® also offers superior lumbar support with our proprietary high-resiliency foam providing unsurpassed energy attenuation and fatigue-fighting comfort. The easy-care Marquesa fabric features ultra-violet resistance and durability providing years of trail use and enjoyment. With available "creature comfort" options such as seat heaters, lumbar support, seat pockets and Camelbak™ pouches; the MasterCraft Rubicon® provides the ultimate seat designed with the rigors of trail-riding and the daily commute in mind. The Rubicon® bolts directly into most Jeep® CJ-5 and all CJ-7 and YJ models making it an excellent interior upgrade for many applications. The Jeep® TJ, XJ and JK models are also bolt-in when used with our vehicle specific mounting kits. MasterCraft's Rubicon® also works well with the Suzuki Samurai and Toyota Tacoma in addition to many of the popular overlanding vehicles. All MasterCraft seat models have been extensively sled and drop-tested and exceeds Federal Motor Vehicle Safety Standard (FMVSS) requirements so you can wheel your vehicle with confidence. Available in five standard color combinations, the MasterCraft Rubicon® will not only improve your vehicle's ride and comfort, it will compliment and enhance the interior as well!

- Race Inspired Off-Road Seat
- Three-Quarter Rise Bolster for Superior Containment
- High Resiliency Foam for Exceptional Energy Attenuation and Comfort
- Secondary Suspension Straps for Additional Support and Fatigue-Fighting Comfort
- 5-Point Seat Belt Slots (with additional seat belt loops to secure harnesses in place)
- Tested and Validated to Comply with Applicable FMVSS
- Direct Bolt-In Application for Most Jeep® CJ-5s, all Jeep® CJ-7 & YJs
- Hip Containment: 6.5-inches
- Upper Torso Containment: 5.5-inches

**MADE IN THE USA** 

TACTICAL COVER	BLACK	OD GREEN	TAN
	524124	524121	524128

BRS COVER	BLACK w/RED	BLACK w/BLUE	ALL BLACK	SMOKE w/GRAY	TAN w/BROWN
	524112	524113	524114	524117	524118

CUSTOM ADD-ON OPTIONS	
ADD PASSENGER'S SIDE - LUMBAR LEFT	600001
ADD DRIVER'S SIDE - LUMBAR RIGHT	600002
ADD ELECTRONIC SEAT HEATER (Installed)	600006
ADD REAR SEAT POCKET	600008
ADD CAMELBAK POCKET	600060
ADD CAMELBAK SET (Pocket, Reservoir & Tube included)	600061



**NEW PRODUCT**

Tactical Cover Black    Tactical Cover OD Green    Tactical Cover Tan    Black w/Black Center and Red Sides    Black w/Black Center and Blue Sides    Black w/Black Center and Black Sides    Smoke w/Black Center and Gray Sides    Desert Tan w/Black Center and Brown Haze Sides



\* For Full Dimensions See Pg. 48

## NOMAD™ BUDGET SUSPENSION SEAT

The MasterCraft Safety Nomad™ is a budget-minded import version based on our legendary fixed-back Rubicon®. Designed from the ground-up as a true suspension seat, the Nomad™ features precision-crafted tubular construction, an open-mesh liner, and high resiliency foam for comfort, longevity and durability. The Nomad™ offers many of the same features and qualities that made MasterCraft a cornerstone brand among off-road and Jeep® enthusiasts. Mounting and installation is easy too; the seat will install in the same applications as our popular Rubicon®. The easy-care, wear-resistant proprietary UV-treated seat cover fabric ensures your seat will last many seasons. Just like all MasterCraft Safety seating, the value-packed Nomad™ has been extensively sled and drop-tested and exceeds Federal Motor Vehicle Safety Standard (FMVSS) requirements so you and your family can have confidence in your equipment on the trail. The MasterCraft Safety Nomad™ works well in the Ford Ranger and Bronco, Jeep® Cherokee as well as other Jeep® models such as the JK, TJ, YJ, and CJ-5 and CJ-7 models. Available in black only.

- True Suspension Off-Road Seat
- Three-Quarter Rise Bolster for Superior Containment
- High Resiliency Foam for Enhanced Energy Attenuation and Comfort
- Precision Crafted Tubular Frame Construction
- Secondary Suspension Straps for Additional Support and Fatigue-Fighting Comfort
- 5-Point Seat Belt Slots
- Tested and Validated to Comply with Applicable FMVSS
- Hip Containment: 6.5-inches
- Upper Torso Containment: 5.5-inches
- Direct Bolt-in Application for most Jeep® CJ5s, all Jeep CJ7 & YJs
- Other Vehicle Fitments Available when Used with MasterCraft Safety Supplied Mounting Kits. See Page 27 for More Info.

	ALL BLACK
SINGLE SEAT	530004
PAIR	525200

\* SAVE \$20 When Ordered as a Pair!



\* For Full Dimensions See Pg.48

## SPORTSMAN™ \$329.95 PREMIUM FIXED-BACK SUSPENSION SEAT

A favorite seating choice among long-time MasterCraft loyalists, the Sportsman™ cut its teeth pre-running Baja and chasing down racecars in the Nevada desert. Due to its mounting design and seat angle, the Sportsman™ is ideal for early or late model Broncos and it adapts just as easily to the Ford Ranger, Toyota Pickups, and Chevy K5 Blazer and GMC S-Series. The Sportsman™ also fits nicely in the full-size Ford, Chevy and Dodge trucks and is the perfect seat for the everyday commute or the terrain of Baja.

The Sportsman™ offers superior fatigue-fighting comfort and energy-attenuation through the use of MasterCraft's exclusive military grade high-density closed-cell foam. The easy-care Marquesa fabric provides ultra-violet resistance and extreme wear-test durability ensuring your MasterCraft Sportsman™ can withstand the abuses of your desert wanderings. Additional options such as seat heaters and lumbar support offer much needed warmth and comfort during long nights chasing Baja while the optional seat back pockets or Camelbak™ pouch provide compartments to stash essentials or offer much needed hydration. Whether you're out weekend 4-wheeling, pre-running, or trying to get a spare part to a SCORE Trophy Truck® in the middle of Baja, the Sportsman™ is the seat you can trust your body to.

- Race Inspired Off-Road Seat
- Three-Quarter Rise Bolster for Superior Containment
- High Resiliency Foam for Exceptional Energy Attenuation and Comfort
- Precision Crafted Laser Cut Tubular Frame Construction
- Secondary Suspension Straps for Additional Support & Fatigue-Fighting Comfort
- 5-Point Seat Belt Slots (with additional seat belt loops to secure harnesses in place)
- Tested and Validated to Comply with Applicable FMVSS
- Hip Containment: 6.5-inches
- Upper Torso Containment: 5.5-inches

MADE IN THE USA

BRS COVER	BLACK w/RED	BLACK w/BLUE	ALL BLACK	SMOKE w/GRAY	TAN w/BROWN
	576212	576213	576214	576217	576218

CUSTOM ADD-ON OPTIONS	
ADD PASSENGER'S SIDE - LUMBAR LEFT	600001
ADD DRIVER'S SIDE - LUMBAR RIGHT	600002
ADD ELECTRONIC SEAT HEATER (Installed)	600006
ADD REAR SEAT POCKET	600008
ADD CAMELBAK POCKET	600060
ADD CAMELBAK SET (Pocket, Reservoir & Tube included)	600061



\* For Full Dimensions See Pg. 48

**ORIGINAL™ \$289.95**  
PREMIUM SUSPENSION SEAT

Just as the name implies, the MasterCraft Original® was designed in 1970 by MasterCraft's founder, Jack Miller, and quickly became the suspension seat of choice for the off-road racing community. While the MasterCraft product line has evolved over the last four decades, the updated Original® continues to be a staple among the Sand Sport crowd.

The Original® is a low-profile suspension seat designed with four gusseted vertical tabs for mounting. At the request of our family-oriented customers and the Sand Car manufacturers, we were asked to bring back our "Original" suspension seat for recreational sand buggies and rails. We agreed, but first this versatile seat had to undergo a few design upgrades as the sand cars of today are much faster than in 1970 when the first Original® was introduced. In order to provide a seat that can endure the rigors of the extreme sand market, we started by strengthening the four vertical mounting tabs and integrating these key structural components into the seat frame. MasterCraft then modified the seat design to allow more room in the hip area as an extra measure of comfort and during extreme runs in Glamis or Dumont Dunes. With available "creature comfort" options such as seat heaters, lumbar support, seat pockets and Camelbak™ pouches, the MasterCraft Original® provides unparalleled options perfect for sand sports.

- Four Vertical Tab Gusseted Mounting
- Low Profile Suspension Seat
- 5-Point Seat Belt Slots
- Loops to Secure Restraint Harnesses in Place
- Tested and Validated to Comply with Applicable FMVSS
- Hip containment: 7-inches
- Upper torso containment: 5.5-inches
- Sitting Level Height from Floor: 3-inches
- Mounting Area: 14-inch Wide and 18-inch Front to Back
- Available in Black or Gray

**MADE IN THE USA**

BOX STITCH COVER	ALL BLACK	SMOKE w/GRAY
	576019	576020

CUSTOM ADD-ON OPTIONS	
ADD PASSENGER'S SIDE - LUMBAR LEFT	600001
ADD DRIVER'S SIDE - LUMBAR RIGHT	600002
ADD ELECTRONIC SEAT HEATER (Installed)	600006
ADD REAR SEAT POCKET	600008
ADD CAMELBAK POCKET	600060
ADD CAMELBAK SET (Pocket, Reservoir & Tube included)	600061



Black w/Black Center and Black Sides  
Smoke w/Gray Center and Gray Sides



**70°**  
**18 LBS.**  
\* For Full Dimensions See Pg. 48



**CAMBER® \$624.95**  
PREMIUM SUSPENSION SEAT

The first reclining suspension seat developed specifically for Muscle Car enthusiasts, the MasterCraft Camber® offers comfort, containment, safety and fatigue-fighting ergonomics perfect for Open Track Days, AutoCross, or Boulevard Cruising. Designed with both form and function in mind, MasterCraft's Camber® seat features a mid-rise bolster for ease of ingress and egress while also providing superior containment; even during the most spirited adventures. Featuring a durable yet comfortable UV-resistant fabric, the Camber® also offers superior lumbar support with our proprietary high-resiliency foam offering the ultimate in energy attenuation and fatigue-fighting comfort. The machined billet lever and 9-position reclining mechanism provide for years of trouble-free use while the integrated seat belt slots provide harness guides ensuring your five-point belts stay in place.

With available "creature comfort" options such as seat heaters, lumbar support, and seat pockets, the MasterCraft Camber® provides the ultimate seat balancing everyday practicality with features specifically designed for Muscle Car use. Additionally, MasterCraft seats are sled and drop-tested and exceed Federal Motor Vehicle Safety Standard (FMVSS) requirements. The Camber® shares the same flexibility in mounting as our popular Baja RS®, Rubicon®, and Nomad series seats and is the perfect addition to your early GM, Ford, Chrysler, or Dodge Muscle Car, or Truck. Available in two standard color combinations and in either cloth and vinyl, or all vinyl, the MasterCraft Camber® with enhance both the comfort and interior of your vehicle!

CUSTOM ADD-ON OPTIONS	
ADD PASSENGER'S SIDE - LUMBAR LEFT	600001
ADD DRIVER'S SIDE - LUMBAR RIGHT	600002
ADD ELECTRONIC SEAT HEATER (Installed)	600006
ADD REAR SEAT POCKET	600008
ADD CAMELBAK POCKET	600060
ADD CAMELBAK SET (Pocket, Reservoir & Tube included)	600061



**31 LBS.**

**S2/4™ \$449.95**  
**PREMIUM UTV SEAT**

Upgrade the comfort of your Polaris® RZR® with MasterCraft's new S 2/4™ seat designed to endure the rigors and versatility of the UTV market. With deep bolsters for superior containment during those rough spots, and featuring a removable bottom cushion for easy cleaning, the S 2/4™ is specifically constructed for the Polaris® RZR®. MasterCraft's S 2/4™ features a pass-through at the base of the rear cushion to easily reach through the seat and access the seat release lever, making removing your seats for cleaning quick and simple.

- Easy Installation with our Mounts for most Polaris® RZR Models
- Upholstered with Easy-to-Clean Marine Grade Vinyl and Cloth
- Reach Through Access Slot for Easy Use of the RZR's Seat Quick Release
- Built-in Release Strap Included on Back of Seat for Use in Rear Seat Position
- Hip Containment: 4-inches

**MADE IN THE USA**

	BLACK w/RED	BLACK w/BLUE	BLACK w/SILVER	ALL BLACK
ALL VINYL VERSION	573402	573403	573404	573405
CLOTH & VINYL VERSION	573406	573407	573408	573409

CUSTOM ADD-ON OPTIONS		
ADD PASSENGER'S SIDE - LUMBAR LEFT	600001	
ADD DRIVER'S SIDE - LUMBAR RIGHT	600002	
ADD ELECTRONIC SEAT HEATER (Installed)	600006	
ADD REAR SEAT POCKET	600008	
ADD CAMELBAK POCKET	600060	
ADD CAMELBAK SET (Pocket, Reservoir & Tube included)	600061	



**EXCLUSIVE PASS-THROUGH LEVER ACCESS**

The S 2/4™ features a pass-through at the base of the rear cushion to easily reach through the seat and access the seat release lever, making removing your seats for cleaning quick and simple.



CLOTH CENTER w/ VINYL OUTER:  
Black w/Red

CLOTH CENTER w/ VINYL OUTER:  
Black w/Blue



CLOTH CENTER w/ VINYL OUTER:  
Black w/Silver

CLOTH CENTER w/ VINYL OUTER:  
All Black



\* For Full Dimensions See Pg. 48



VINYL CENTER w/ VINYL OUTER:  
Black w/Red

VINYL CENTER w/ VINYL OUTER:  
Black w/Blue

VINYL CENTER w/ VINYL OUTER:  
Black w/Silver

VINYL CENTER w/ VINYL OUTER:  
All Black



**PWR SPORT™** \$329.95  
PREMIUM SUSPENSION TV SEAT

Upgrade the comfort of your side-by-side with MasterCraft's PWRSport™ seat designed to endure the rigors and versatility of the UTV market. Specifically constructed for the Yamaha Rhino® and Kawasaki Teryx®, MasterCraft's PWRSport™ is a direct bolt-in replacement seamlessly adapting to the factory OEM mounts while retaining a full-size seat profile. Offered with options such as seat heaters, lumbar support, seat pockets or Camelbak™ pouch, the PWRSport™ is upholstered with a high-performance UV treated Marquesa fabric making this the ideal interior upgrade for your Side-by-Side. Featuring laser-notched tube construction, the PWRSport™ is finished with MasterCraft's military grade energy-attenuating impact foam offering improved comfort and fatigue-fighting lumbar support. The MasterCraft PWRSport™ also includes integrated shoulder harness guide loops and anti-sub and lap belt slots keeping your five-point restraints ideally positioned. The three-quarter-rise bolster offers ease of ingress and egress while the 7-inches of hip containment keep you positioned in your seat during spirited adventures. The MasterCraft PWRSport™ fits both the driver and the passenger position of the Yamaha Rhino® and Kawasaki Teryx® UTVs and requires no special tools or additional mounts for installation. MasterCraft also offers a matching headrest pad cover (sold separately). The PWRSport™ will fit with the Yamaha Rhino® factory seatbelt.

- Direct Bolt-In Replacement for the Yamaha Rhino® and Kawasaki Teryx®
- Three-Quarter Rise Bolster for Superior Containment
- Easy Care UV Treated Marquesa Fabric
- High Resiliency Foam for Enhanced Energy Attenuation & Comfort
- Includes Anti-Sub and Lap Seat Belt Slots
- Shoulder Harness Loops to Secure Harness Bar Restraints in Place
- Tested and Validated to Comply with Applicable FMVSS
- Hip Containment: 7-inches

**MADE IN THE USA**

BRS COVER	BLACK w/RED	BLACK w/BLUE	ALL BLACK	SMOKE w/GRAY
NO Headrest	573002	573005	573004	573014
WITH Headrest	574002	574005	574004	574014

CUSTOM ADD-ON OPTIONS	
ADD PASSENGER'S SIDE - LUMBAR LEFT	600001
ADD DRIVER'S SIDE - LUMBAR RIGHT	600002
ADD ELECTRONIC SEAT HEATER (Installed)	600006
ADD REAR SEAT POCKET	600008
ADD CAMELBAK POCKET	600060
ADD CAMELBAK SET (Pocket, Reservoir & Tube included)	600061



70°  
20 LBS.  
\* For Full Dimensions See Pg. 48

**GENESYS II by IMPACT**  
FIBERGLASS HARDSHELL RACE SEAT

Utilizing advanced aerospace manufacturing technology, the new Genesys II seat is the lightest fiberglass seat we've ever produced. The technology, utilizing advanced negative displacement "AND" technology, allows for greater consistency while eliminating unnecessary weight. The result is a seat that is 30% lighter than its predecessor, while maintaining superior tensile and compressive properties. The Genesys II also features integrated structural reinforcement panels in areas subjected to torsional stress to ensure strength under load. The Genesys II is compatible with all multi-point restraint systems Impact offers, and is FIA Homologated.

Sized to meet the needs of most drivers, the Genesys II utilizes shoulder harness guides positioned to fit a wide range of drivers. Suitable for drivers with waist measurements up to 36", the removable bolster padding can be removed for a semi-custom fit. The channels created by the removable cushions also allow for increased airflow. The seat cushion has also been revised, utilizing higher density foam for increased bottoming resistance and comfort. Deep bolstering and shoulder support provide comfort and containment. Upholstered with heavy-duty, tear-resistant fabric, the seat cover is fire resistant. Standardized side mounting locations make for easy retrofitting into cockpits already set up for side mounted seats.

- Light-weight Fiberglass Monocoque Construction
- Shoulder Support & Deep Bolster for Enhanced Containment
- Four, Five, Six Point Harness Compatible
- Frontal Head Restraint Compatible
- Ideally Suited for Taller/Larger Drivers
- Heavy-Duty, Tear Resistant & Fire Retardant Fabric
- We have mounts for the Polaris RZR for this seat see page 29 for more info.



### 3G™ & 3G4™

#### PREMIUM SUSPENSION RACE SEAT

Originally developed to attenuate the high-speed and violent impacts common to short course off-road racing, MasterCraft Safety's 3G™ is a race-proven suspension seating system constructed from laser-notched 4130 (chromoly) tubing for superior structural integrity. Designed with input from champion racers, the MasterCraft 3G™ offers improved lateral support while the 10-inch deep-sided bolster provides exceptional hip containment, so important in today's competition. The removable bottom cushion allows for speedy seat customization during driver changes, as well as easy cleanup after the race. Borrowing technology from our military line of blast mitigating seats, the MasterCraft 3G™ provides unparalleled attenuating properties, reducing impact energies and lumbar stress by 84% (as shown in independent lab testing required of defense suppliers). Featuring flame resistant foam and upholstery, the materials used in the manufacture of MasterCraft's 3G™ meet and exceed FMVSS 302 and California's TB117 fire safety requirements. Finished with our exclusive Dirt Sport Cover, this popular enhancement reinforces common wear areas of the seat with our carbon fiber patterned vinyl. MasterCraft Safety's 3G™ installs using a reinforced, heavy-duty flat strap mount (four tab mount also available, specify when ordering). Additional upgrades such as seat heaters and lumbar support offer much needed warmth and comfort during long stretches of SCORE Baja racing while optional seat back pockets provide compartments to stash essentials. Looking for a hydration solution for your racecar? Be sure to check out our Camelbak™ pouch option!

- 5-Point Seat Belt Slots
- Flat Strap Mount (Four Tab Mount Available with Our 3G-4, Please Specify)
- Deep-Sided Race Seat with 10-inches of Hip Containment
- Improved Lateral Support with 8-inches of Upper Torso Containment
- Laser Notched 4130 (Chromoly) Tubular Frame Construction
- High Resiliency Foam for Exceptional Energy Attenuation
- Independent Lab Tests Indicate an 84% Reduction in Impact Energy
- Secondary Suspension Straps Provide Unparalleled Support
- Manufactured Using Flame Resistant Foam and Upholstery
- Removable Cushion for Driver Customization and Easy Clean-Up
- Size: 36-Inches Tall x 22-Inches Wide x 28-Inches Deep
- Mounting Area: 15-Inches Front to Back and 13.5-Inches Wide On Center
- Sitting Level Height from Floor: 4-Inches

MADE IN THE USA 

#### 3G™

3G™ - FLAT STRAP MOUNT	BLACK w/RED	BLACK w/BLUE	ALL BLACK	SMOKE w/GRAY
STANDARD WIDTH	568012	568013	568014	568019
1" WIDER <b>+\$75</b>	568022	568023	568024	568029
2" WIDER <b>+\$75</b>	568032	568033	568034	568039



#### FLAT STRAP MOUNT

3G™ Uses Our FlatStrapMount™ Technology

For applications requiring a four-tab vertical mount, MasterCraft Safety also offers our 3G-4 seat. Offering all the same features and benefits as our standard flat strap 3G™ seat, the 3G-4 provides flexibility in mounting to a roll-cage with the vertical four tab mount. Integrating the mounting tabs into the seat frame allowed MasterCraft to strengthen the overall integrity of these key structural components, ensuring your seat frame can handle all the same abuses as your chassis! Don't settle for inferior construction, only a genuine MasterCraft seat offers this level of craftsmanship!

#### 3G4™

3G4™ - 4-TAB MOUNT	BLACK w/RED	BLACK w/BLUE	ALL BLACK	SMOKE w/GRAY
STANDARD WIDTH	572012	572013	572014	572019
1" WIDER <b>+\$75</b>	572022	572023	572024	572029
2" WIDER <b>+\$75</b>	572032	572033	572034	572039



#### TAB MOUNT

3G-4™ Uses Our TabMount™ Technology. Fits any 14" x 18" Four Vertical Tab Mounting System



Black w/Red Center and Red Sides

Black w/Blue Center and Blue Sides

Black w/Black Center and Black Sides

Smoke w/Gray Center and Gray Sides



CUSTOM ADD-ON OPTIONS		
ADD PASSENGER'S SIDE - LUMBAR LEFT	600001	
ADD DRIVER'S SIDE - LUMBAR RIGHT	600002	
ADD ELECTRONIC SEAT HEATER (Installed)	600006	
ADD REAR SEAT POCKET	600008	
ADD CAMELBAK POCKET	600060	
ADD CAMELBAK SET (Pocket, Reservoir & Tube)	600061	



\* For Full Dimensions See Pg. 48

## PROSEAT™ & PRO4™ PREMIUM SUSPENSION RACE SEAT

MasterCraft® Safety's ProSeat™ has been the standard for reliability and comfort in competitive off-road race vehicles and luxury pre-runners for over a decade. Constructed from laser-notched 4130 (chromoly) tubing for superior structural integrity and offering a "flat strap" installation, MasterCraft's ProSeat™ incorporates a higher-rise bolster for more than 9.5-inches of hip containment. Just like our top-of-the-line 3G™, the ProSeat™ features MasterCraft's proprietary energy attenuating high-resiliency foam reducing impact injuries and lumbar stress by more than 84%. Featuring flame resistant foam and upholstery, the materials used in the manufacture of MasterCraft's ProSeat™ meet and exceed FMVSS 302 and California's TB117 fire safety requirements. Additional upgrades are available such as a removable cushion for ease of clean-up and customized fitment during driver changes, while seat heaters and lumbar support offer much needed warmth and comfort during long stretches of SCORE Baja racing. Optional seat back pockets provide compartments to stash essentials or you can opt for the Camelbak™ pouch for a much needed hydration solution for your racecar.

- 5-Point Seat Belt Slots
- Flat Strap Mount (Four Tab Mount Available with Our Pro-4, Please Specify)
- Deep-Sided Race Seat with 9.5-inches of Hip Containment
- Laser Notched 4130 (Chromoly) Tubular Frame Construction
- High Resiliency Foam for Exceptional Energy Attenuation
- Independent Lab Tests Indicate an 84% Reduction in Impact Energy
- Secondary Suspension Straps Provide Unparalleled Support
- Manufactured Using Flame Resistant Foam and Upholstery
- Available with a Removable Cushion for Driver Customization and Easy Clean-Up
- Size: 35-Inches Tall x 22-Inches Wide x 28-Inches Deep
- Mounting Area: 15-Inches Front to Back and 13-Inches Wide On Center
- Sitting Level Height from Floor: 5-Inches

**MADE IN THE USA**

### PROSEAT™

#### FIXED CUSHION-BRS COVER

PROSEAT™ - FLAT STRAP MOUNT	BLACK w/RED	BLACK w/BLUE	ALL BLACK	SMOKE w/GRAY
STANDARD WIDTH	560012	560013	560014	560019
1" WIDER <b>+\$75</b>	560112	560113	560114	560119
2" WIDER <b>+\$75</b>	560212	560213	560214	560219

#### REMOVABLE CUSHION-BRS COVER (+\$125)

PROSEAT™ - FLAT STRAP MOUNT	BLACK w/RED	BLACK w/BLUE	ALL BLACK	SMOKE w/GRAY
STANDARD WIDTH	561012	561013	561014	561019
1" WIDER <b>+\$75</b>	561112	561113	561114	561119
2" WIDER <b>+\$75</b>	561212	561213	561214	561219



#### FLAT STRAP MOUNT

ProSeat™ Uses Our FlatStrapMount™ Technology

For applications requiring a four-tab vertical mount, MasterCraft Safety also offers our Pro4™ seat. Offering all the same features and benefits as our standard flat strap ProSeat™ seat, the Pro4™ provides flexibility in mounting to a roll-cage with the vertical four tab mount. Integrating the mounting tabs into the seat frame allowed MasterCraft to strengthen the overall integrity of these key structural components, ensuring your seat frame can handle all the same abuses as your chassis! Don't settle for inferior construction, only a genuine MasterCraft seat offers this level of craftsmanship!

### PRO4™

#### FIXED CUSHION-BRS COVER

PRO4™ - 4-TAB MOUNT	BLACK w/RED	BLACK w/BLUE	ALL BLACK	SMOKE w/GRAY
STANDARD WIDTH	564012	564013	564014	564019
1" WIDER <b>+\$75</b>	564112	564113	564114	564119
2" WIDER <b>+\$75</b>	564212	564213	564214	564219

#### REMOVABLE CUSHION-BRS COVER (+\$125)

PRO4™ - 4-TAB MOUNT	BLACK w/RED	BLACK w/BLUE	ALL BLACK	SMOKE w/GRAY
STANDARD WIDTH	565012	565013	565014	565019
1" WIDER <b>+\$75</b>	565112	565113	565114	565119
2" WIDER <b>+\$75</b>	565212	565213	565214	565219



#### TAB MOUNT

Pro4™ Uses Our TabMount™ Technology. Fits any 14" x 18" Four Vertical Tab Mounting System

CUSTOM ADD-ON OPTIONS	
ADD PASSENGER'S SIDE - LUMBAR LEFT	600001
ADD DRIVER'S SIDE - LUMBAR RIGHT	600002
ADD ELECTRONIC SEAT HEATER (Installed)	600006
ADD REAR SEAT POCKET	600008
ADD CAMELBAK POCKET	600060
ADD CAMELBAK SET (Pocket, Reservoir & Tube included)	600061



\* For Full Dimensions See Pg. 48



## HS-1 by **IMPACT** CARBON FIBER HARDSHELL RACE SEAT

Impact's HS-1 is a top-of-the-line performance seat purposely engineered to withstand torsional stress and abuses common to off-road competition. Constructed from 100% epoxy-reinforced carbon fiber, the Impact HS-1 features an embedded single-piece laser cut and drilled mounting bracket providing continuously connected support, strength, and rigidity. Precision alignment of the restraint and mount openings is achieved through 5-axis CNC trimming. This extraordinary level of craftsmanship ensures uniformity throughout the seat resulting in the repeatable accuracy chassis builders and prep crews value. The HS-1's lightweight ergonomic design is a product of CAD engineering coupled with real world input from renowned chassis builders including Jimco and racers like Rob MacCachren. Finished with fire retardant high resiliency foam for superior energy attenuation, the Impact HS-1 offers improved comfort and support over competitive seats on the market. Upholstered with a non-slip and heavy-duty 300,000 double-rub abrasion and fire resistant fabric specially engineered to endure the extreme abuses of Baja, the HS-1 is the ideal balance of rugged and refined. Black only, replacement seat covers and cushions are readily available.

- **Infused Carbon Fiber with Epoxy Reinforcement**
- **5-Axis CNC Trimmed for Precision Restraint and Mount Alignment**
- **Single-Piece Laser-Cut and Drilled Mounting Bracket**
- **Fire Retardant, High Resiliency Foam for Enhanced Energy Attenuation**
- **Non-Slip, Abrasion Resistant and Fire Retardant Upholstery**
- **Includes Anti-Sub and Lap Seat Belt Slots**
- **Hip Containment: 14-inches**

**MADE IN THE USA**

	ALL BLACK
STANDARD HEIGHT	60000001
3" TALLER	60000002

REPLACEMENT PARTS	
REPLACEMENT SEAT COVER (Std Height Seat)	61000001
REPLACEMENT SEAT COVER (3" Taller Seat)	61000002
REPLACEMENT LOWER CUSHION	61000003
REPLACEMENT UPPER CUSHION	61000004
SHOULDER BELT OPENING RINGS	61000005
LAP BELT OPENING RINGS	61000006

\* Replacement Seat Covers Include Cushions and Replacement Trim Pieces.

The seat mount openings for the HS-1 are precisely drilled on a 5-axis CNC providing for a consistently patterned installation for accurate mounting. The single-piece laser cut and drilled mounting bracket is fully integrated and bonded with the seat resulting in improved torsional strength as well as mount holes and weld nuts that maintain a continuous tolerance and do not wallow out over time.

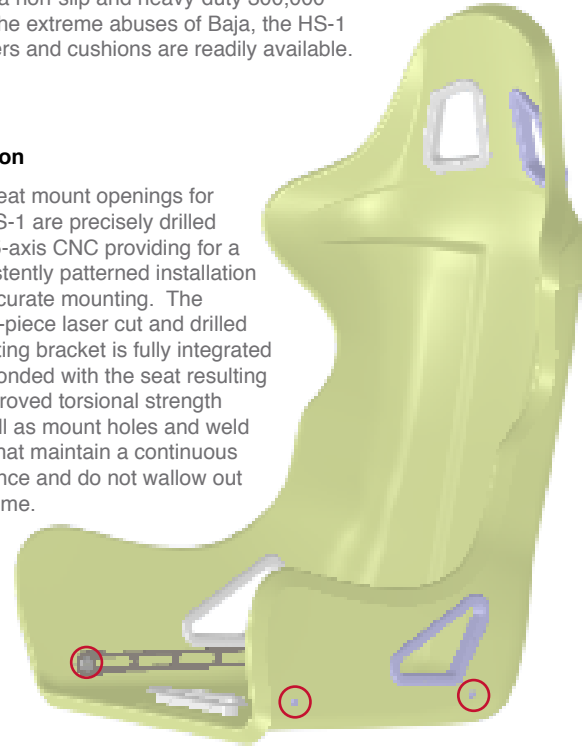

\* Measurements shown are for the standard height seat.

\* For Full Dimensions See Pg. 48



## FACTORY FIT™ SLIP COVERS

### UPGRADE YOUR OEM REAR BENCH

Looking to match your OE Jeep® rear bench seats to your new MasterCraft Baja RS® or Rubicon® front seats with minimal hassle and expense? Upgrade your factory OEM fold-and-tumble rear bench with MasterCraft's Factory Fit™ slip covers. Available in color combinations to match your Rubicon or Baja RS, the Factory Fit slipcovers are an inexpensive and hassle-free way to complete your Jeep's interior.

**MADE IN THE USA** 

JEEP JK '13-'15, 4 DOOR	BLACK w/RED	BLACK w/BLUE	ALL BLACK	SMOKE w/GRAY	TAN w/BROWN
STANDARD BRS STITCH	702602	702603	702604	702607	702608
DIRTSPORT STITCH PATTERN	702612	702613	702614	702617	702618
<small>* JK Slip Covers include Adjustable Headrest Covers.</small>					
JEEP JK '11-'12, 2 DOOR	BLACK w/RED	BLACK w/BLUE	ALL BLACK	SMOKE w/GRAY	TAN w/BROWN
STANDARD BRS STITCH	702622	702623	702624	702627	702628
DIRTSPORT STITCH PATTERN	702632	702633	702634	702637	702638
<small>* JK Slip Covers include Adjustable Headrest Covers.</small>					
JEEP JK '11-'12, 4 DOOR	BLACK w/RED	BLACK w/BLUE	ALL BLACK	SMOKE w/GRAY	TAN w/BROWN
STANDARD BRS STITCH	702642	702643	702644	702647	702648
DIRTSPORT STITCH PATTERN	702652	702653	702654	702657	702658
<small>* JK Slip Covers include Adjustable Headrest Covers.</small>					
JEEP JK '07-'10, 2 DOOR	BLACK w/RED	BLACK w/BLUE	ALL BLACK	SMOKE w/GRAY	TAN w/BROWN
STANDARD BRS STITCH	702662	702663	702664	702667	702668
DIRTSPORT STITCH PATTERN	702672	702673	702674	702677	702678
<small>* JK Slip Covers include Adjustable Headrest Covers.</small>					
JEEP JK '07-'10, 4 DOOR	BLACK w/RED	BLACK w/BLUE	ALL BLACK	SMOKE w/GRAY	TAN w/BROWN
STANDARD BRS STITCH	702682	702683	702684	702687	702688
DIRTSPORT STITCH PATTERN	702692	702693	702694	702697	702698
<small>* JK Slip Covers include Adjustable Headrest Covers.</small>					
JEEP TJ '03-'06	BLACK w/RED	BLACK w/BLUE	ALL BLACK	SMOKE w/GRAY	TAN w/BROWN
STANDARD BRS STITCH	702702	702703	702704	702707	712708
DIRTSPORT STITCH PATTERN	702712	702713	702714	702717	702718
JEEP TJ '97-'02	BLACK w/RED	BLACK w/BLUE	ALL BLACK	SMOKE w/GRAY	TAN w/BROWN
STANDARD BRS STITCH	702722	702723	702724	702727	702728
DIRTSPORT STITCH PATTERN	702732	702733	702734	702737	702738
JEEP CJs AND YJs '65-'95	BLACK w/RED	BLACK w/BLUE	ALL BLACK	SMOKE w/GRAY	TAN w/BROWN
STANDARD BRS STITCH	702742	702743	702744	702747	702748
DIRTSPORT STITCH PATTERN	702752	702753	702754	702757	702758

Representative image  
For Color Fitting Only



Actual Color & Fabric Sample

**2-DOOR JK - BENCH COVER**  
**DIRTSPORT COVER:**  
Smoke w/Gray  
Shown

Representative image  
For Color Fitting Only



Actual Color & Fabric Sample

**4-DOOR JK - BENCH COVER**  
**DIRTSPORT COVER:**  
Smoke w/Gray  
Shown



Black  
w/Black Center  
and Black Sides



**DIRTSPORT COVER:**  
Black  
w/Black Center  
and Black Sides



**DIRTSPORT COVER:**  
Black  
w/Red Center  
and Red Sides  
\* Black w/Blue,  
Smoke w/Gray  
and Tan w/Brown Haze  
not shown.



Actual Color & Fabric Sample  
Black  
w/Black Center  
and Red Sides



Actual Color & Fabric Sample  
Black  
w/Black Center  
and Blue Sides



Actual Color & Fabric Sample  
Smoke  
w/Black Center  
and Gray Sides



Actual Color & Fabric Sample  
Desert Tan  
w/Black Center  
and Brown Haze Sides

\* Jeep TJ 97-02 & 03-06 Bench Slip Covers Shown.

## RUBICON BENCH SEATS PREMIUM SUSPENSION REAR BENCH

Are your kids always fighting over the front seat? Now the entire family can enjoy the comfort of MasterCraft's suspension technology with our exclusive Rubicon Bench. Constructed with the same comfort and durability that made MasterCraft suspension seats a mainstay in the recreational off-road market, the MasterCraft Rubicon Bench was developed to bolt right into popular Jeep models such as the CJ7, YJ and TJ series with basic hand tools and no drilling is required. Looking to replace the uncomfortable OE rear bench in your 4-door Jeep JK? The 46-inch MasterCraft Rubicon will bolt right in with the purchase of our JK rear mounting kit (part no. 624407). If you prefer a bucket seating solution for more containment, the same rear mount kit will also adapt to accept two Baja RS, Rubicon or Nomad seats. The Rubicon Bench seats two people comfortably and also features slots for the lap belts as well as anti-sub slots and shoulder harness loops if five point belts are utilized. The MasterCraft Rubicon Bench also works well in the Jeep CJ5s, early Broncos (1966-1977) as well as Land Cruisers, Land Rovers and International Scouts with some drilling required. The MasterCraft Rubicon Bench varies in width from 36-inch to 46-inch depending on application.

### MADE IN THE USA

JEEP JK '07-'15	BLACK w/RED	BLACK w/BLUE	ALL BLACK	SMOKE w/GRAY	TAN w/BROWN
STANDARD BRS STITCH	310152	310153	310154	310157	310158
DIRTSPORT STITCH PATTERN	310162	310163	310164	310167	310168
JEEP TJ '03-'06	BLACK w/RED	BLACK w/BLUE	ALL BLACK	SMOKE w/GRAY	TAN w/BROWN
STANDARD BRS STITCH	310172	310173	310174	310177	310178
DIRTSPORT STITCH PATTERN	310182	310183	310184	310187	310188
JEEP TJ '97-'02	BLACK w/RED	BLACK w/BLUE	ALL BLACK	SMOKE w/GRAY	TAN w/BROWN
STANDARD BRS STITCH	310192	310193	310194	310197	310198
DIRTSPORT STITCH PATTERN	310202	310203	310204	310207	310208
JEEP YJ '87-'95	BLACK w/RED	BLACK w/BLUE	ALL BLACK	SMOKE w/GRAY	TAN w/BROWN
STANDARD BRS STITCH	310212	310213	310214	310217	310218
DIRTSPORT STITCH PATTERN	310222	310223	310224	310227	310228
JEEP CJ '76-'86	BLACK w/RED	BLACK w/BLUE	ALL BLACK	SMOKE w/GRAY	TAN w/BROWN
STANDARD BRS STITCH	310232	310233	310234	310237	310238
DIRTSPORT STITCH PATTERN	310242	310243	310244	310247	310248
FORD BRONCO '66-'77	BLACK w/RED	BLACK w/BLUE	ALL BLACK	SMOKE w/GRAY	TAN w/BROWN
STANDARD BRS STITCH	310252	310253	310254	310257	310258
DIRTSPORT STITCH PATTERN	310262	310263	310264	310267	310268

BENCH CUSTOM ADD-ON OPTIONS	
ADD ELECTRONIC SEAT HEATER (Installed)	600006 (x2)
ADD REAR SEAT POCKET	600008 (x2)
ADD CAMELBAK POCKET	600060 (x2)
ADD CAMELBAK SET (Pocket, Reservoir & Tube included)	600061 (x2)

\* Please note, benches require two of each seat option.

Special Shipping Note: Due to the size of our Bench Seats, orders must be shipped via common carrier. The average freight charge for shipping within the continental U.S. is \$185.00. We will provide a price quote for shipping on bench seats.



**BRS COVER:**  
Black  
w/Black Center  
and Black Sides



**DIRTSPORT COVER:**  
Black  
w/Black Center  
and Black Sides

Not all MasterCraft bench seats are compatible in all applications. Additionally, some applications require seat mounts or adapter kits (sold separately) for proper mounting and to maintain critical, O.E. safety equipment such as, but not limited to seat belts, air-bag warning sensors, etc. Contact a MasterCraft Safety Customer Service Representative for the appropriate MasterCraft seat for your particular application and details regarding proper seat mounting procedures.

\* For Full Dimensions See Pg. 48



**BRS COVER:**  
Black  
w/Black Center  
and Red Sides

**BRS COVER:**  
Black  
w/Black Center  
and Blue Sides

**BRS COVER:**  
Smoke  
w/Black Center  
and Gray Sides

**BRS COVER:**  
Desert Tan  
w/Black Center  
and Brown Haze Sides

**DIRTSPORT:**  
Black  
w/Red Center  
and Red Sides

**DIRTSPORT:**  
Black  
w/Blue Center  
and Blue Sides

**DIRTSPORT:**  
Smoke  
w/Gray Center  
and Gray Sides

**DIRTSPORT:**  
Desert Tan  
w/Brown Haze Center  
and Brown Haze Sides

## ORIGINAL BENCH SEAT PREMIUM SUSPENSION REAR BENCH

The MasterCraft Original Bench suspension seat is the ideal addition for recreational sand cars, buggies, and off-road vehicles. Designed so the rest of your gang can ride along in safety, the Original Bench features four gusseted vertical tabs for mounting and is three inches shorter front to back to allow more legroom for the rear passengers. Featuring 7-inches of hip containment, the Original Bench also offers the lap belt slots as well as anti-sub slots and shoulder harness loops for use with five-point belts. The MasterCraft Original Bench seat is available in standard 40-inch width.

- Lap & Anti-Sub Seat Belt Slots (with additional seatbelt loops to secure harnesses in place)
- Precision Crafted Laser Cut Tubular Frame Construction
- High Resiliency Foam for Superior Energy Attenuation & Comfort
- Durable UV-Treated Marquesa Fabric Designed to Match Front MasterCraft Seats
- Many Available Options such as Seat Heaters, Seat Pockets and More
- Federal Motor Vehicle Safety Standard Tested & Approved
- Size: 23-inches tall x 40-inches wide x 24-inches deep
- Mounting Area: 15-Inches Front to Back & 32-Inches Wide On Center
- Sitting Level Height from Floor: 4-Inches

### MADE IN THE USA

BOX STITCH COVER	ALL BLACK	SMOKE w/GRAY
ORIGINAL SHORTY BENCH	773004	773009

BENCH CUSTOM ADD-ON OPTIONS	
ADD ELECTRONIC SEAT HEATER (Installed)	600006 (x2)
ADD REAR SEAT POCKET	600008 (x2)
ADD CAMELBAK POCKET	600060 (x2)
ADD CAMELBAK SET (Pocket, Reservoir & Tube included)	600061 (x2)

\* Please note, benches require two of each seat option.

\* For Full Dimensions See Pg. 48



Black  
w/Black Center  
and Black Sides



Smoke  
w/Gray Center  
and Gray Sides

**VEHICLES REQUIRING MOUNTING BRACKETS**

BUICK SKYLARK 1964-1967, DRIVER	625002
BUICK SKYLARK 1964-1967, PASSENGER	625003
CHEVY CAMARO 1967-1967, DRIVER	625004
CHEVY CAMARO 1967-1967, PASSENGER	625005
CHEVY CAMARO 1970-1974, DRIVER	625006
CHEVY CAMARO 1970-1974, PASSENGER	625007
CHEVY CHEVELLE 1964-1967, DRIVER	625008
CHEVY CHEVELLE 1964-1967, PASSENGER	625009
CHEVY CHEVELLE 1968-1972, DRIVER	626010
CHEVY CHEVELLE 1968-1972, PASSENGER	625011
CHEVY CORVETTE 1968-1982, DRIVER	625012
CHEVY CORVETTE 1968-1982, PASSENGER	625013
CHEVY CORVETTE 1962-1965, DRIVER	625014
CHEVY CORVETTE 1962-1965, PASSENGER	625015
CHEVY S-10 1994-2004, DRIVER	625024
CHEVY S-10 1994-2004, PASSENGER	625025
CHEVY TRAILBLAZER SS 2001-2009, DRIVER	625026
CHEVY TRAILBLAZER SS 2001-2009, PASSENGER	625027
DODGE CHALLENGER 1970-1974, DRIVER	624602
DODGE CHALLENGER 1970-1974, PASSENGER	624603
DODGE RAM 1981-1993, DRIVER	624606
DODGE RAM 1981-1993, PASSENGER	624607
FORD MUSTANG 1964-1973, DRIVER	621402
FORD MUSTANG 1964-1973, PASSENGER	621403
FORD MUSTANG 1974-1978, DRIVER	621404
FORD MUSTANG 1974-1978, PASSENGER	621405
FORD MUSTANG 1979-1993, DRIVER	621406
FORD MUSTANG 1979-1993, PASSENGER	621407
FORD MUSTANG 1974-1978, DRIVER	624408
FORD MUSTANG 1974-1978, PASSENGER	624409
FORD EXPEDITION 2007-2017, DRIVER	620709
FORD EXPEDITION 2007-2017, PASSENGER	620710
NISSAN/DATSUN 720 PICKUP 1980-1986, DRIVER	626002
NISSAN/DATSUN 720 PICKUP 1980-1986, PASSENGER	626003
OLDSMOBILE CUTLASS 1964-1967, DRIVER	625022
OLDSMOBILE CUTLASS 1964-1967, PASSENGER	625023
PLYMOUTH BARRACUDA 1940-1974, DRIVER	624604
PLYMOUTH BARRACUDA 1940-1974, PASSENGER	624605
PONTIAC FIREBIRD 1967-1969, DRIVER	625016
PONTIAC FIREBIRD 1967-1969, PASSENGER	625017
PONTIAC FIREBIRD 1970-1974, DRIVER	625018
PONTIAC FIREBIRD 1970-1974, PASSENGER	625019
PONTIAC GTO 1964-1967, DRIVER	625020
PONTIAC GTO 1964-1967, PASSENGER	625021
TOYOTA LAND CRUISER 1980-MARCH 1986, DRIVER	623212
TOYOTA LAND CRUISER 1980-MARCH 1986, PASSENGER	623213
TOYOTA LAND CRUISER APRIL 1986-1989, DRIVER	623214
TOYOTA LAND CRUISER APRIL 1986-1989, PASSENGER	623215
TOYOTA LAND CRUISER 1990-1997, DRIVER	623216
TOYOTA LAND CRUISER 1990-1997, PASSENGER	623217
TOYOTA TACOMA 2005-2015, DRIVER	623218
TOYOTA TACOMA 2005-2015, PASSENGER	623219
TOYOTA TACOMA 2016+, DRIVER	623220
TOYOTA TACOMA 2016+, PASSENGER	623210

**SEAT MOUNTING BRACKETS**

**FOR MOST POPULAR MUSCLE CAR VEHICLES**

Seamlessly install Phenom® seats in your 1960s-2000s muscle car with these brackets. Buick, Chevy, Dodge, Ford, Oldsmobile, Pontiac, Plymouth, and Totya mounts.

This also works for Baja RS, Rubicon, Original and other MasterCraft seats.



**VEHICLES REQUIRING MOUNTING BRACKETS**

TOYOTA TACOMA 2016+, DRIVER	623220
TOYOTA TACOMA 2016+, PASSENGER	623221
TOYOTA FJ CRUISER 2007-2014, DRIVER	623210
TOYOTA FJ CRUISER 2007-2014, PASSENGER	623211
TOYOTA 4RUNNER 1995-2002, DRIVER	623206
TOYOTA 4RUNNER 1995-2002, PASSENGER	623207
TOYOTA 4RUNNER 2009+, DRIVER	623208
TOYOTA 4RUNNER 2009+, PASSENGER	623209



**SEAT MOUNTING BRACKETS AND ADJUSTERS**

**FOR MOST POPULAR OFF-ROAD VEHICLES**

Seamlessly install and adapt your MasterCraft seat to your vehicle using our line of heavy-duty and easy-to-install bracket and mounting kits. Looking for adjustability? MasterCraft also offers durable, easy-glide seat adjusters with a lever or towel bar release. All mounting bracket and adjuster hardware is fully tested ensuring FMVSS compliance for your seating system.

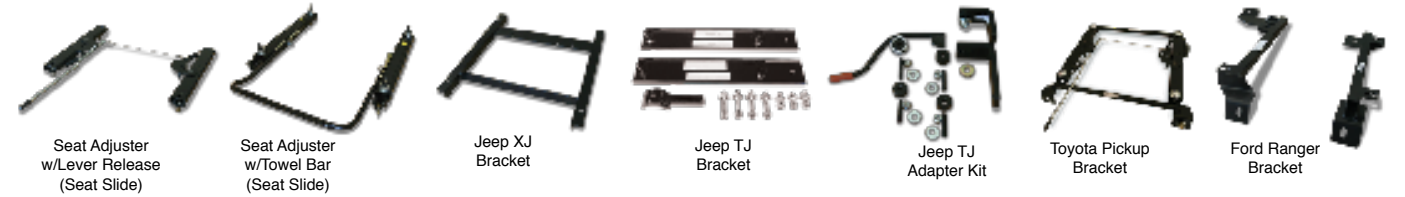

**VEHICLES REQUIRING MOUNTING BRACKETS**

SEAT SLIDES ONLY W/LEVER RELEASE	620030
SEAT SLIDES ONLY, OEM STYLE W/TOWEL BAR	620031
FORD BRONCO 66-77, MOUNTING BRACKET, DRIVER (INCLUDES ADJUSTER W/TOWEL BAR)	620704
FORD BRONCO 66-77, MOUNTING BRACKET, PASSENGER (INCLUDES ADJUSTER W/TOWEL BAR)	620705
FORD RANGER EXTENDED CAB 83-92, MOUNTING BRACKET, DRIVER (Mount Only, Order Adjuster Separately)	621304
FORD RANGER EXTENDED CAB 83-92, MOUNTING BRACKET, PASSENGER (Mount Only, Order Adjuster Separately)	621305
FORD RANGER STANDARD CAB 93-02, MOUNTING BRACKET, DRIVER (Mount Only, Order Adjuster Separately)	621104
FORD RANGER STANDARD CAB 93-02, MOUNTING BRACKET, PASSENGER (Mount Only, Order Adjuster Separately)	621105
FORD RANGER EXTENDED CAB 93-02, MOUNTING BRACKET, DRIVER (Mount Only, Order Adjuster Separately)	621106
FORD RANGER EXTENDED CAB 93-02, MOUNTING BRACKET, PASSENGER (Mount Only, Order Adjuster Separately)	621107
FORD F-150 STANDARD CAB 92-96, MOUNTING BRACKET, DRIVER (Mount Only, Order Adjuster Separately)	622904
FORD F-150 STANDARD CAB 92-96, MOUNTING BRACKET, PASSENGER (Mount Only, Order Adjuster Separately)	622905
TOYOTA PICKUP 84-88, MOUNTING BRACKET, DRIVER OR PASSENGER (Mount Only, Order Adjuster Separately)	623204
TOYOTA PICKUP STANDARD CAB 89-95, MOUNTING BRACKET, DRIVER (Mount Only, Order Adjuster Separately)	623304
TOYOTA PICKUP STANDARD CAB 89-95, MOUNTING BRACKET, PASSENGER (Mount Only, Order Adjuster Separately)	623305
TOYOTA TACOMA STANDARD CAB 95-03, MOUNTING BRACKET, DRIVER (Mount Only, Order Adjuster Separately)	623404
TOYOTA TACOMA STANDARD CAB 95-03, MOUNTING BRACKET, PASSENGER (Mount Only, Order Adjuster Separately)	623405
JEEP TJ 97-02, ADAPTER KIT, DRIVER (Use D.E.M. Sliders)	624004
JEEP TJ 97-02, ADAPTER KIT, PASSENGER (Use D.E.M. Sliders)	624005
JEEP TJ (INC. UNLIMITED) 03-06, ADAPTER KIT, DRIVER (Use D.E.M. Sliders)	624204
JEEP TJ (INC. UNLIMITED) 03-06, ADAPTER KIT, PASSENGER (Use D.E.M. Sliders)	624205
JEEP JK 07-17, FRONT SEAT ADAPTER KIT, DRIVER (Use D.E.M. Sliders)	624405
JEEP JK 07-17, FRONT SEAT ADAPTER KIT, PASSENGER (Use D.E.M. Sliders)	624406
JEEP JK 07-17 (4 DOOR), REAR SEAT MOUNTING BRACKET - BENCH or BUCKET SEATS	624407
JEEP CHEROKEE (XJ) 84-96, ADAPTER KIT, DRIVER or PASSENGER (Use D.E.M. Sliders)	624500
JEEP CHEROKEE (XJ) 97-01, ADAPTER KIT, DRIVER or PASSENGER (Use D.E.M. Sliders)	624501
SUZUKI SAMURAI 86-94, ADAPTER KIT, DRIVER or PASSENGER	624502
POLARIS RZR XP650-900 08-15, MOUNTING BRACKET, DRIVER or PASSENGER (FOR SPORTSMAN SEAT)	624409
POLARIS RZR, S2/4 MOUNTING BRACKET, DRIVER or PASSENGER, FRONT or BACK (FOR S2/4 SEAT ONLY)	624411
POLARIS RZR, GENESYS MOUNTING BRACKET, DRIVER or PASSENGER, FRONT or BACK (FOR GENESYS SEAT ONLY)	624413

\* Toyota Pickup 84-88 (623204) Please Specify Cab Type and Year.

**VEHICLES THAT HAVE DIRECT BOLT-IN APPLICATIONS**

	FRONT SEAT	REAR SEAT
CHEVY BLAZER/K5 69-94 (*If Equipped w/Original Bucket Seats Only)	BAJA RS, RUBICON, SPORTSMAN (Use D.E.M. Sliders)	N/A
FORD BRONCO 66-77	N/A	FIT COVER or 40" RUBICON BENCH
JEEP C/J-5 76-83	BAJA RS, RUBICON (Use D.E.M. Sliders)	FIT COVER or 36" RUBICON BENCH
JEEP C/J-7 76-86	BAJA RS, RUBICON (Use D.E.M. Sliders)	FIT COVER or 36" RUBICON BENCH
JEEP WRANGLER YJ 87-95	BAJA RS, RUBICON (Use D.E.M. Sliders)	FIT COVER or 36" RUBICON BENCH
JEEP TJ 97-02	N/A	FIT COVER or 40" RUBICON BENCH
JEEP TJ (INCL UNLIMITED) 03-06	N/A	FIT COVER or 40" RUBICON BENCH
KAWASAKI TERYX 08-11	PWR SPORT	*SPECIAL
YAMAHA RHINO 04-11	PWR SPORT	40" ORIGINAL BENCH *SPECIAL

\* Please note, Chevy Blazer K5 (65-94)

## SEAT ADD-ON OPTIONS

### TO CUSTOMIZE OUR SEATS TO YOUR EXACT NEEDS

Whether it is commuting during the week or running errands on the weekend, we spend a lot of time in our vehicles. Match your seats to your lifestyle and add comfort and convenience with custom options such as seat heaters, lumbar support and seat pockets! **Add-on Seat Options are not available on Nomad seats.**



### ADJUSTABLE LUMBAR SUPPORT

This patented lumbar support system adjusts up to 3-inches in the lower lumbar area for improved support and even pressure distribution. The advanced design of the Schukra® system allows the unit to hold its form, even during the most rigorous trail or racing adventures. The Schukra Lumbar System can be installed into any MasterCraft seat at the time of assembly and is available with a left or right side adjustment handle.



### ELECTRONIC SEAT HEATER

Ideal for cold weather or used year-round to relieve tension or stress in the lower back, Seat Heaters are pre-installed during the seat's assembly so be sure to include this option when ordering your new MasterCraft seat. The Seat Heaters are 12-volt, made in the U.S.A units and meet all FMVSS 302 flammability requirements. The included electrical harness is complete with switch and features an indexed GXL 18 wire to simplify installation. Available on any MasterCraft® seats or benches. Note: these Seat Heaters are not compatible with the factory JK seat heater switches.



### ADJUSTABLE HEADREST

Three-position Adjustable Headrest is integrated into the steel seat frame and is available as an option only on the MasterCraft Baja RS®. This upgrade cannot be installed after the seat is made, so be sure to request this when ordering your seat. **Only available on the BAJA RS and RUBICON BENCHES for 4-door JKs.**

### MAP POCKET

Add a durable and roomy pocket to the back of your MasterCraft seat to conveniently store all your essentials and keep your items safely contained during spirited trail rides or while conquering the Baja desert. The Rear Seat Pocket measures about 8-inch x 11-inch and features a ruggedized molded plastic No. 10 zipper closure for maximum durability and strength. Map Pocket is available as an option at the time of order on any MasterCraft® Safety seat.



### CAMELBAK™ POCKET or POCKET w/SET

Looking for a hydration solution for your racecar or trail vehicle? Designed to fit Camelbak's Omega 3 Water Beast reservoir, MasterCraft can add a Camelbak™ pouch to the back of your seat to ensure that you are equipped with hydration for any situation. The Omega 3 Water Beast offers a Big Bite valve with rugged construction and Hydro-Guard anti-microbial technology ensuring delivery of safe and clean water during extreme operational conditions.



CUSTOM ADD-ON OPTIONS		
ADD ADJUSTABLE LUMBAR SUPPORT - HANDLE LEFT	600001	
ADD ADJUSTABLE LUMBAR SUPPORT - HANDLE RIGHT	600002	
ADD ELECTRONIC SEAT HEATER (Installed)	600006	
ADD REAR SEAT POCKET	600008	
ADD CAMELBAK POCKET	600060	
ADD CAMELBAK SET (Packet, Reservoir & Tube included)	600061	

## SEAT SAVER

### PROTECT YOUR SEATS

New and improved! Not only does the MasterCraft Seat Saver protect your MasterCraft seats from the weather and elements, it now also allows you to sit in the seat with the Seat Saver on (an important feature if you've had a rough day on the trail and are covered in muck)! Constructed from heavy-duty moisture-repellant Cordura® with easy-to-use hook-and-loop latches on the front and sides, this durable seat accessory is a must-have item to keep your MasterCraft seats protected from the environment and occasional mishaps. To use the seat with the Seat Saver on, simply pull up the hook-and-loop latches and the flap pushes in so you can sit in the seat without the need to remove the Seat Saver. Available in black and in sizes to fit most MasterCraft® Safety seats.



3G/3G-4 Model Shown

SEAT SAVER WITHOUT HEADREST	640154	
SEAT SAVER FOR 3G & 3G-4	640155	
SEAT SAVER FOR FIXED HEADRESTS	640158	
SEAT SAVER FOR RUBICON BENCH WITHOUT HEADRESTS	640161	
SEAT SAVER FOR ADJUSTABLE HEADRESTS	640164	

\* Please Specify if You Have a 1" Wider or 2" Wider Seat When Ordering.

## SEAT BOOSTER PADS

Our seat booster pad is offered in a 2-inch thickness with your choice of a bottom cushion, back cushion, or a bottom cushion attached to a back cushion as a combo. Available in Black Only.

SEAT BOTTOM PAD ONLY 2-Inch Thick	600026	
SEAT BACK PAD ONLY 2-Inch Thick	600027	
SEAT BACK & BOTTOM PAD COMBO 2-Inch Thick	600028	



## PSS KITS

### PERSONAL SANITATION KITS

Gain much needed "relief" during long stretches in the racecar with MasterCraft's "Personal Sanitation System" (PSS Kit). This condom style catheter with drainage tube features heavy-duty vinyl construction and double-sided tape ensuring the kit stays in place and you stay clean and dry, even during the most rigorous racing.



	680100	
--	--------	--

## CAMELBAK™ ACCESSORIES

Using a Camelbak™ Set (see previous page) with your MasterCraft seat? Get your accessories, supplies and other needs from us as well.

CAMELBAK RESERVOIR (INCL TUBE)	600062	
CAMELBAK CLEANING KIT	600063	
CAMELBAK TUBE DIRECTOR	600064	
CAMELBAK CLEANING TABLETS	600065	







### GRAB HANDLES

Do your passengers need something to hold onto while conquering the Rubicon Trail or Moab? These easy-to-install grab handles adapt to your Jeep or any off-road vehicle with a roll cage in just a matter of minutes with the hook and loop system and offer the often-needed "Oh No!" handle. Manufactured from 1.5-inch nylon webbing for strength and durability, the 5-inch Thermo-Press handle is ergonomically shaped and does not collapse in your hand. MasterCraft also added a third mounting strap for added support when you really need it. Available in Black for 2-inch or 3-inch diameter tubing. \*Not recommended for support during ingress and egress of the vehicle.



STANDARD 2" BLACK - SINGLE	683104	
STANDARD 2" BLACK - PAIR	683204	
STANDARD 3" BLACK - SINGLE	683404	
STANDARD 3" BLACK - PAIR	683304	
2" UTV BLACK (2-HANDLE) - SINGLE	684104	
2" UTV BLACK (2-HANDLE) - PAIR	684204	
JK BLACK - REAR (SET OF 2)	684205	
JK BLACK - FRONT AND REAR (SET OF 4)	684206	
JL BLACK - FRONT AND REAR (SET OF 4)	684207	



### HEAD REST GRAB HANDLE

Manufactured from 1-inch polyester webbing for strength and durability. The 5-inch Thermo-Press handle does not collapse in your hand. Easy to install hook and loop enclosure. Available in Black.

	683604	
--	--------	--



### 1" x 6' (or 15') STRAP w/Vinyl Coated S-Hooks

1" x 6' nylon strap with cam buckles and large vinyl coated S-hooks. Rated at 1200 pounds maximum load. Available in Red only.

RED - 6' LENGTH	400001	
RED - 15' LENGTH	400003	



### 1" x 6' RATCHET STRAP

1" x 6' nylon strap with wide handle ratchet (for folks with big hands) with either large vinyl coated S-hooks OR Snap Hooks. Rated at 2800 pounds maximum load. Available in Red only.

RED w/ VINYL COATED S-HOOKS	400004	
RED w/ SNAP HOOKS	400006	



### 1" x 15' RATCHET STRAP

1" x 15' nylon strap with wide handle ratchet (for folks with big hands) with either large vinyl coated S-hooks OR Snap Hooks. Rated at 2800 pounds maximum load. Available in Red only.

RED w/ VINYL COATED S-HOOKS	400007	
RED w/ SNAP HOOKS	400008	



### 2" x 7' RATCHET STRAP w/Chain Extension or Twisted Snap Hooks

2" x 7' heavy-duty strap features wide handle ratchet and Anchor hooks on chains OR large twisted snap hooks. Rated at 10,000 pounds maximum load. Available in Red or Yellow.

RED w/ CHAIN EXTENSION	400011	
YELLOW w/ CHAIN EXTENSION	400012	
RED w/ TWISTED SNAP HOOKS	400013	
YELLOW w/ TWISTED SNAP HOOKS	400014	

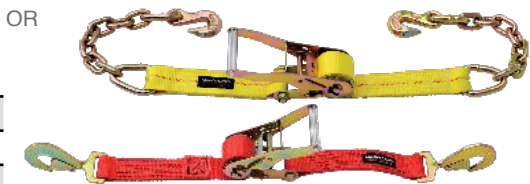

### 2" x 8' RATCHET STRAP w/Twisted Snap Hooks & Axle Loop

2" x 8' heavy-duty strap features wide handle ratchet, Snap hook at one end and an Axle loop with protective sleeve at the other. 12" of adjustment. Rated at 10,000 pounds maximum load.

RED	400015	
YELLOW	400016	

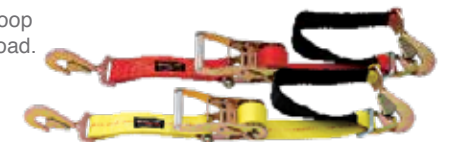



### 2-inch x 2-inch CAM-LOCK 5-POINT RESTRAINTS x/QSRs



#### QSR - QUICK SAFETY RELEASE

Offering ease of adjustment, the QSR hardware adjusts by simply flipping up the lever and pulling down on the shoulder harness end. QSR hardware is not available on the lap belts.

**SFI COMPLIANT**  
SPEC 16.5

	BOLT-IN MOUNTING	111154
	SNAP-IN MOUNTING	111254

MasterCraft Safety delivers on all promises of delivering the most comfortable, easy to tighten restraint on the market. Featuring integral adjusters at the Cam-Lock end, MasterCraft's newest Cam-Lock restraints solve the issue of adjuster placement and ease of tightening. Constructed of high strength polyester webbing for the greatest strength and longevity, MasterCraft's Integral-adjuster restraints are available in the race proven 2" x 2" configuration, in the popular 5-point configuration. There are two mounting configuration options; a bolt-in version, and a snap-in version. MasterCraft's Integral-adjuster, cam-lock restraints are SFI certified to the more stringent 16.5 specification and are legal for use in both the SCORE and BITD desert racing series. Anti-submarine belt included. Available in Black Only.

### 2-inch x 2-inch - 5-POINT RESTRAINTS x/QSRs

5-Point Latch and Link System with Integrated Latch Guard. 2-inch x 55-inch Pull Down Lap Belt and 2-inch x 48-inch Dual Shoulder Harness with Quick Release Adjusters. Available in SFI 16.5 with Bolt-In, Snap-In or Wrap-Around ends. Anti-submarine belt included. Available in Black Only.



**SFI COMPLIANT**  
SPEC 16.5

BOLT-IN MOUNTING	111144	
SNAP-IN MOUNTING	111244	



#### QSR - QUICK SAFETY RELEASE

Offering ease of adjustment, the QSR hardware adjusts by simply flipping up the lever and pulling down on the shoulder harness end. QSR hardware is not available on the lap belts.

### 3-inch x 3-inch - 5-POINT RESTRAINTS w/QSRs

5-Point Latch and Link System with Integrated Latch Guard. Features 3-inch x 55-inch Pull Down Lap Belts and 3-inch x 48-inch Dual Shoulder Harnesses with our exclusive QSRs for ease of adjustment, especially during speedy driver changes. Available in SFI 16.1 with Bolt-In, Snap-In or Wrap-Around ends. Anti-submarine belt included. Available in Black Only.



**SFI COMPLIANT**  
SPEC 16.1

BOLT-IN MOUNTING	111134	
SNAP-IN MOUNTING	111234	

### 2-inch x 2-inch - 5-POINT RESTRAINTS

5-Point Latch and Link System with Integrated Latch Guard. 2-inch x 55-inch Pull Down Lap Belt and 2-inch x 48-inch Dual Shoulder Harness. Available in SFI 16.1 with Bolt-In, Snap-In or Wrap-Around ends. Anti-submarine belt included. Available in Black Only.



**SFI COMPLIANT**  
SPEC 16.1

BOLT-IN MOUNTING	113004	
SNAP-IN MOUNTING	113204	

### 3-inch x 3-inch - 5-POINT RESTRAINTS

5-Point Latch and Link System with Integrated Latch Guard. Features 3-inch x 55-inch Pull Down Lap Belts and 3-inch x 48-inch Dual Shoulder Harness. Available in SFI 16.1 or SFI 16.5 with Bolt-In, Snap-In or Wrap-Around ends. Anti-submarine belt included. Available in Black Only.



**SFI COMPLIANT**  
SPEC 16.1

BOLT-IN MOUNTING	110004	
SNAP-IN MOUNTING	110204	

### TRAIL RUNNER 4-POINT RESTRAINTS

MasterCraft Safety Trail Runner Restraints are an innovative easy to use solution for those looking for increased containment and security, while remaining easy to use. An easy to use OEM-style push-button buckle, and simple intuitive adjusters make for the upmost ease of use. Trail Runner restraints are available in three colors to match a variety of interior color schemes. The provided ends come in two types...bolt-in for applications where mounting tabs and most OEM mounts are used, and Snap-In for those applications that utilize eye-bolts. The ends are also adjustable for length, and can be removed for wrap-around applications. Optional sewn-in shoulder pads are available for an additional \$29.95 per set. Note: a shoulder height cross-bar is mandatory for proper shoulder restraint mounting.



#### TRAIL RUNNER RESTRAINTS

BLACK - BOLT-IN MOUNTING	114004	
BLACK - SNAP-IN MOUNTING	114204	
RED - BOLT-IN MOUNTING	114002	
RED - SNAP-IN MOUNTING	114202	
BLUE - BOLT-IN MOUNTING	114003	
BLUE - SNAP-IN MOUNTING	114203	

### CUSTOM RESTRAINTS

Custom Restraint Systems are available for any application. Please call for more info.

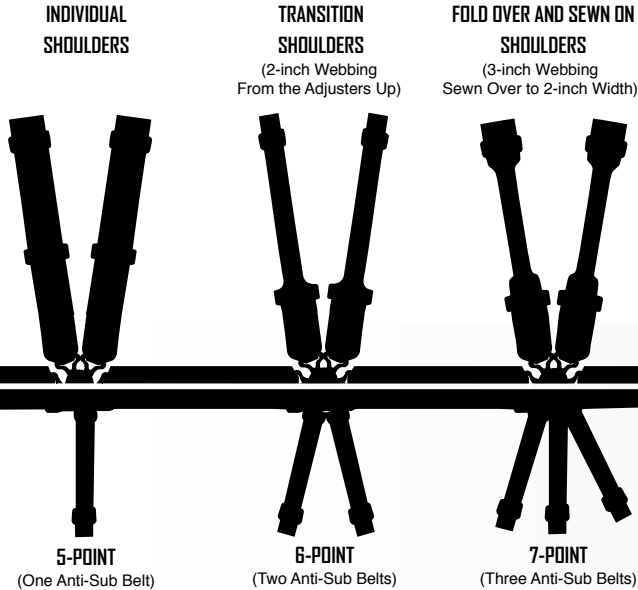

CUSTOM ADD-ON OPTIONS		
SEWN-IN HARNESS PADS	630014	
3-TO-2 TRANSITION ON SHOULDER BELTS	132507	
FOLD OVER AND SEWN ON SHOULDER BELTS	132508	
QSR ADJUSTER UPGRADE (SHOULDER BELTS ONLY)	132503	
RATCHET UPGRADE - LEFT SIDE	132505	
RATCHET UPGRADE - RIGHT SIDE	132506	

### RATCHET ADJUSTER

Available as an option on any of the MasterCraft three-inch 16.1 SFI rated lap belts, MasterCraft's Ratchet adjuster is manufactured from a heat-treated chromoly steel and features a double locking mechanism for added safety. The ratcheting mechanism can be specified for either left or right side use and features a bolt-in installation on the mechanism side while the opposing side features the standard three-bar wrap or bolt-in option (available with clip-in installation as well). The ratcheting mechanism can replace one of the standard lap adjusters (left or right, depending on your preference) allowing the belt to be quickly and easily tightened without the need for outside crew assistance. MasterCraft's ratchet style adjuster is only available with the purchase of a complete set of restraints. The ratcheting system will not be sold individually or with the purchase of a lap belt only. The mechanism uses a 1/4-inch drive ratchet (not included).



RESTRAINT HARDWARE		
SNAP-END MOUNTING HARDWARE (IPC)	600101	
EYE-BOLT, NUT AND WASHER (1 SET)	600102	
BOLT-IN MOUNTING HARDWARE (IPC)	600103	
3-INCH 3-BAR (IPC)	600105	

### HARNESS PADS

MasterCraft harness pads are constructed from flame retardant materials and offer improved shoulder belt comfort for both two-inch and three-inch belts. The harness pads can be sewn into the shoulder belts or are available as a hook-and-loop wrap attachment that can be easily added and adjusted as needed to any existing shoulder harness. Available in Black Only.

SEWN-IN HARNESS PADS		
2-inch HOOK-AND-LOOP HARNESS PADS (Fits 1.75 and 2-inch Belts)	630036	
3-inch HOOK-AND-LOOP HARNESS PADS	630025	

\* Sewn-In Harness Pads on custom restraint orders only. Sewn in Harness pads are not recommended with use of Frontal Head Restraints.





**2" Y-TYPE SPARE TIRE HOLD DOWN**

Y-Type Spare Tire Hold Down constructed of 2" webbing. Best used for Larger Tire Diameters, up to 42". Black only.

	400020	
--	--------	--

**1.75" Y-TYPE SPARE TIRE HOLD DOWN**

Y-Type Spare Tire Hold Down made of 1 3/4" webbing. Best used for Smaller Tire Diameters such as UTV applications. Black only.

	400021	
--	--------	--



**CUSTOM STRAPS AVAILABLE  
CALL FOR QUOTE**



**DRIVER WINDOW NETS**

The MCS Driver's Net is designed for use in off-road chassis' and is a series mandated safety item in several classes in the Lucas Oil Off Road Racing Series. The MCS net is constructed from three individual straps of 1-inch webbing for maximum coverage and improved lateral support. Available as a left or right side installation, each driver's net is adjustable for the ideal fit to your chassis. Features three bar for chassis tube attachments, ratchet strap for adjustability, and quick release connector closure.

**SFI COMPLIANT  
SPEC 27.1**

DRIVER'S NET - LEFT SIDE	652001	
DRIVER'S NET - RIGHT SIDE	652002	

**WINDOW NETS**

Available in our standard 1-inch ribbon style or in our exclusive mesh with 1-inch polyester binding, MasterCraft can custom handcraft window nets from a supplied pattern and to your exacting standards. Simply send us your pattern cut from cardboard or heavy paper (we can also accept most CAD files as well) and note the top, bottom, front and rear of the chassis in addition to the method of attachment. For more detailed instructions please contact a MasterCraft Sales Representative! \*\$45 fee for building nets off of a drawing or CAD file vs. a physical template.

**SFI COMPLIANT  
SPEC 27.1**

STARTING AT \$194.95



Ribbon Style

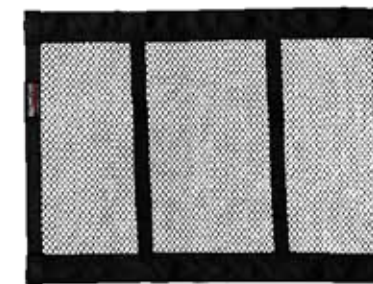

Mesh Style

**CLEVIS PIN**

MasterCraft's adjustable clevis is domestically manufactured from 4130 chromoly and plated to resist corrosion. The bushings for the retaining bolt (not included) are made of stainless steel.

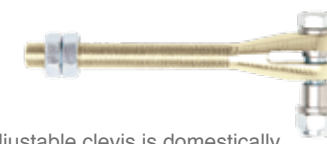

	600100	
--	--------	--



**LIMIT STRAPS**

Any length, custom made-to-order. MasterCraft's limit straps are made from 7000-lb, Mil-Spec rated webbing material - strongest in the business! Simply measure your required eye-to-eye distance and provide us with the dimensions. Double (2-layer), Triple (3-layer), Quad (4-layer). Available in lengths starting at 8-inches in Black only.

STARTING AT

**2" AXLE LOOP w/SLEEVE**

A sleeved 2" webbing axle strap rates at 10,000 pounds max load. Used for securing vehicles via the axle to trailers. Black only.

	400019	
--	--------	--





### PADDED WALKER GEAR BAGS

This handy bag was created especially for Walker Evans. Our 10-inch x 20-inch bag with zipper closure is made of tough, waterproof and tear-resistant material, padded for durability and includes two carry handles.

RED (10" x 20")	640126	
BLACK (10" x 20")	640128	



### IMPACT GUN HOLSTER

Choose from two sizes to accommodate 12-volt to 36-volt Impact Guns. Super rugged vinylized material keeps the impact gun from moving about, and buckle closure secures the gun. Other pockets hold lug nuts, socket and spare battery. Attaches with hook and loop panel and straps. Available in Black only.

SMALL - TYPICALLY HOLDS UP TO 18v (16" x 12" L-Shape)	640130	
LARGE - TYPICALLY HOLDS UP TO 24v (20" x 16" L-Shape)	640131	



### CANVAS TOOL BAG

The MCS Canvas Tool Bag is made from a heavy-duty cotton-duck canvas material and is equipped with two convenient carrying handles and a bag strap for mounting to a door bar or chassis of an off-road truck if desired. Great for storing tools, jumper cables, tow-ropes, and wrench roll-ups, this durable tool bag features a reinforced construction ensuring years of use.

BLACK (17" x 8" x 6" w/1 Bag Strap)	640142	
-------------------------------------	--------	--



### CANVAS TOOL ROLL-UPS

Wrench Roll-Ups Constructed from 100% cotton-duck canvas, these organizers fit open-end box wrenches and close with a hook-and-loop strap.

SMALL ROLL-UP - RED (27" w x 26" t w/16 Slots - 13" Folded)	640174	
SMALL ROLL-UP - BLACK (27" w x 26" t w/16 Slots - 13" Folded)	640139	
2 POCKET ROLL-UP - RED (28 3/4" w x 29" t w/8 Slots - 14" Folded)	640176	
2 POCKET ROLL-UP - BLACK (28 3/4" w x 29" t w/8 Slots - 14" Folded)	640140	
4 POCKET ROLL-UP - RED (28 3/4" w x 29" t w/4 Slots - 14" Folded)	640178	
4 POCKET ROLL-UP - BLACK (28 3/4" w x 29" t w/4 Slots - 14" Folded)	640141	



### VINYL TOOL TOTES

Available in three standard sizes, these water repellent totes feature interior padding on the bottom to protect your tools. The diagonal zipper allows the bag to open wide, providing easy access inside - even with gloves on. To hold the bag in place, we have included bag straps that screw or pop rivet to the floor and wrap around the bag with buckle closure for keeping your tools safely and securely stowed during transport or during the most spirited off-road adventures.

SMALL - RED (12" x 6" x 2 1/2" w/1 Bag Strap)	640101	
SMALL - BLACK (12" x 6" x 2 1/2" w/1 Bag Strap)	640103	
REGULAR - RED (17" x 6" x 2 1/2" w/2 Bag Straps)	640105	
REGULAR - BLACK (17" x 6" x 2 1/2" w/2 Bag Straps)	640107	
LARGE - RED (17" x 8" x 3 1/2" w/2 Bag Straps)	640109	
LARGE - BLACK (17" x 8" x 3 1/2" w/2 Bag Straps)	640111	

### SAT PHONE BAG

Handy bag constructed from heavy-duty cordura features rugged zipper closure and padded interior to safely hold a standard satellite telephone. Also fits half liter bottles like water or other sport drinks. Includes a hook-and-loop strap attachment.

BLACK	640132	
-------	--------	--



### VINYL DOOR BAGS

Created for first-aid supplies, the vinylized bag features a hook-and-loop closure allowing fast and easy access in emergencies. Attaches to nearly any door or panel and will also hold towels, goggles, tools, batteries or anything else! Available in red or black.

RED (8" x 8")	640121	
BLACK (8" x 8")	640123	



### VINYL JIMCO BAGS

As the namesake states, these triangular shaped bags were first used by the winningest off-road chassis builder in SCORE's history. Designed to fit perfectly in the odd shapes between the roll cage tubes, the Jimco bags work great to store extra gloves, maps, and other racing essentials. Attached with durable hook-and-loop closure. Available in red and black.

SMALL - RED	640113	
SMALL - BLACK	640115	
LARGE - RED	640117	
LARGE - BLACK	640119	



### IMPACT GEAR BAG

The Impact Gear Bag is constructed from a heavy-duty reinforced nylon with webbed handle and removable padded shoulder strap that features three separate compartments to hold your helmet, suit, frontal head restraint, gloves, shoes and accessories. The main compartment has a heavy-duty zipper and reinforced base to maintain the shape of the bag during loading and carrying while the two 3/4-zip side pockets provide additional storage for miscellaneous items. This durable bag can handle everyday wear and tear and easily doubles as travel luggage offering excellent storage capacity for weekend trips or transporting all your gear to the race track. Available in Black only.

BLACK (12" h x 12" w x 11" d)	72000010	
-------------------------------	----------	--



### DIRT GEAR BAG

The Canvas Dirt Gear Bag features a helmet storage pocket and 5 outer pouches that vary in size. The bag also features durable handles and a detachable shoulder strap. Available in Black only.

BLACK (13" h x 32" w x 13" d)	640150	
-------------------------------	--------	--



### IMPACT PADDED HELMET BAG

Your helmet protects you. Make sure it's protected when not in use! A double-lined tear resistant nylon outer-shell and soft faux shearling liner keeps your gear safe while two easy-to-carry handles make transporting your helmet to and from the track a breeze. The Impact helmet bag offers a full-length zipper and extra space for easy helmet stowage and integrated pockets provide storage for miscellaneous accessories.

Available in Black only.

BLACK	71000915	
-------	----------	--



### CLAMSHELL HELMET BAG

The soft padding inside protects your valuable helmet from scratches, dings, and dents. Outside you will find a durable Cordura® outer shell with full zipper closure and molded rubber handle. Available in Black only.

BLACK	640148	
-------	--------	--

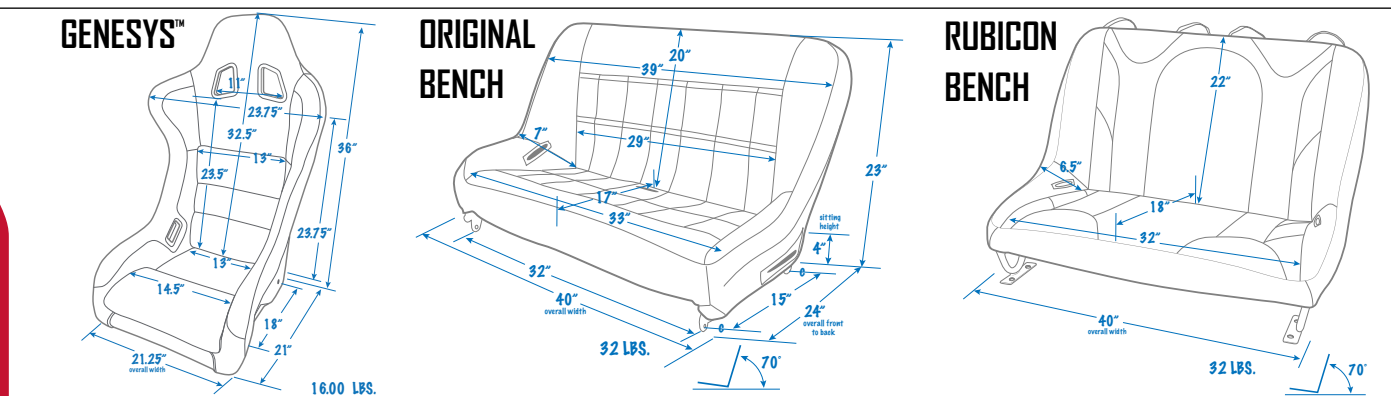
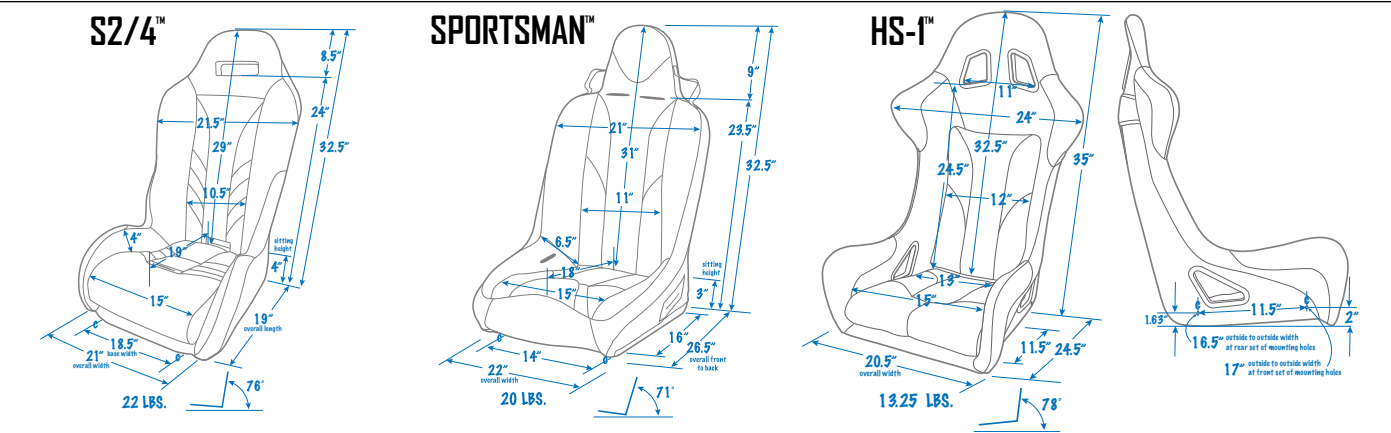
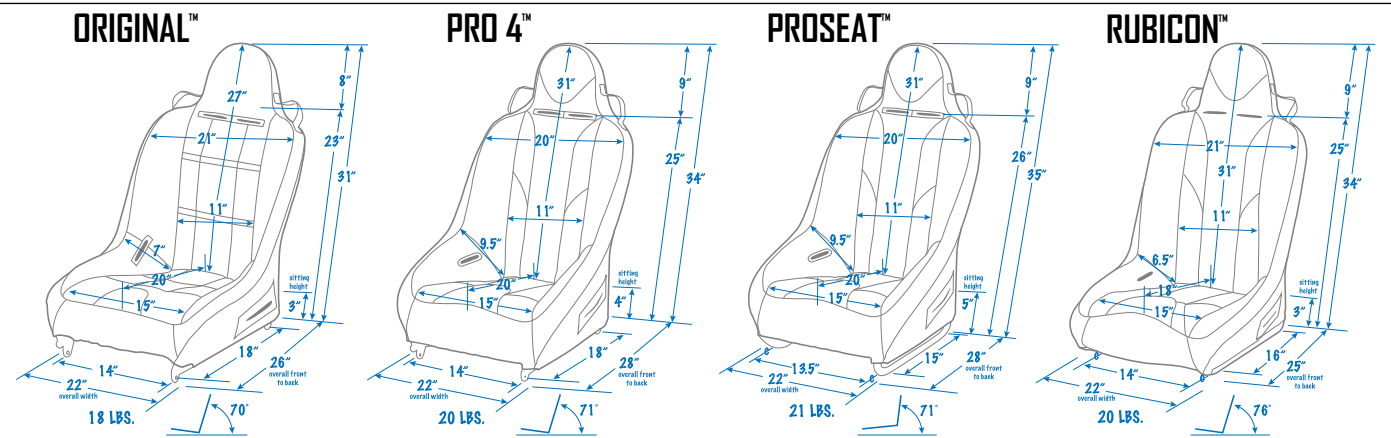
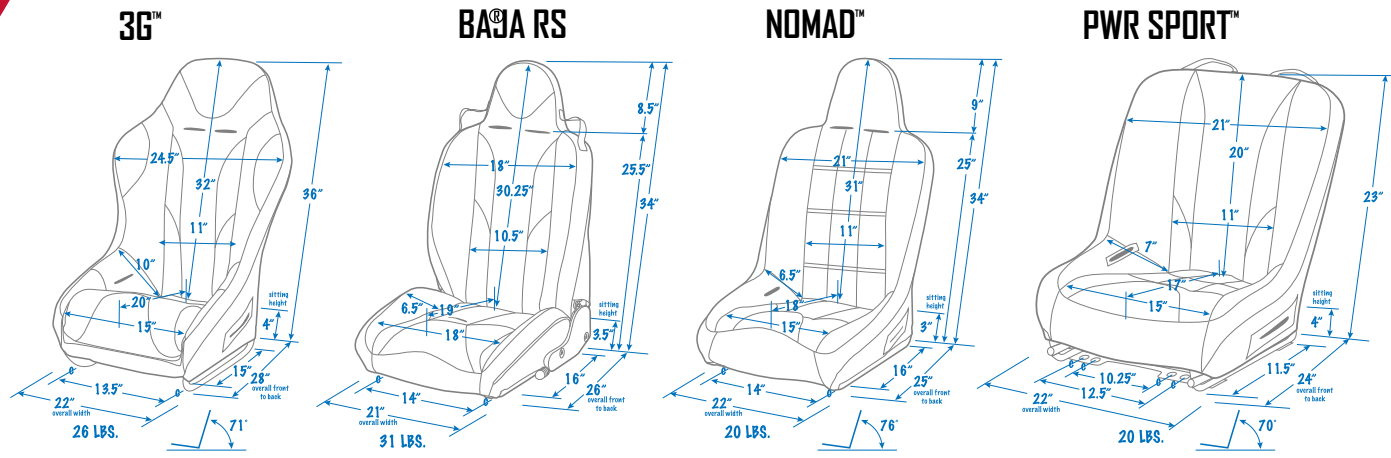

\* OEM Replacement

\* 40" Bench Shown. Available 36-inch to 46-inch lengths; depending on application.

