

MasterCraft®

2016 CATALOG



TABLE of CONTENTS

BAJAS	4
SAHARA	6
RUBICON	8
NOMAD	10
SPORTSMAN	11
ORIGINAL	12
COMPASS	14
PWR SPORT	15
3G & 3G4	18
PRO & PRO4	20
HS-1 HARDSHELL SEAT	22
FACTORY FIT SLIP COVERS	24
ORIGINAL BENCH	25
RUBICON BENCH	26
MOUNTING BRACKETS	27
SEAT OPTIONS	28
SEAT ACCESSORIES	29
OFF-ROAD ACCESSORIES	33
TIE-DOWNS	35
RESTRAINT SYSTEMS	36
NETS & LIMIT STRAPS	37
SEAT SPECS	38

ABOUT MASTERCRAFT

As leading pioneers in the recreational off-road and racing market since 1970, MasterCraft Safety, together with our recently acquired brand, Impact Racing, have been a mainstay and trusted name brand for nearly two generations of off-road and motorsports enthusiasts. The recipe to our success is simple; we were the first and we are the best.

John D. Rockefeller once said, "The secret of success is to do the common thing uncommonly well," while Herman Melville is quoted with saying, "It is better to fail in originality than to succeed in imitation." These two doctrines have been a driving force for Robbie Pierce, owner and CEO of MasterCraft and Impact, and have kept both brands continually advancing and innovating.

MasterCraft is the first company to offer a suspension seat specifically designed for the off-road racing market. This seemingly simple creation provided competitors with comfort and much-needed energy attenuation lacking from the early beam suspension racecars. It didn't take long for the recreational off-road market to demand the same level of comfort and fatigue-fighting ergonomics, thus the Rubicon® and MasterCraft Baja RS® were born. The launch of these two seats for the everyday street-to-trail recreational market forged a new level of comfort and made MasterCraft a brand that has been often imitated but never duplicated.

Founded on a tradition of maximizing racer safety, MasterCraft has since expanded its product lines to include occupant restraints rated to both the SFI 16.1 and 16.5 standard as well as SFI 27.1 rated window nets. MasterCraft also offers a full line of tie downs and ruggedized storage solutions to keep your tools and other necessities safely nestled in your weekend trail rig and your race vehicle securely strapped onto the trailer. We offer many more safety and convenience essentials, so be sure to check out our full-line up of products on the following pages.



Robbie Pierce, MasterCraft® Safety and Impact Racing CEO



When the opportunity to purchase Impact presented itself, Robbie Pierce realized this was his chance to make racers everywhere safer; including himself. With a history deeply rooted in off-road racing safety and a unique understanding of driver needs, it was easy to understand how Pierce and the team at MasterCraft welcomed the challenge of acquiring Impact.

The merging of these two renowned brands combines a powerful wealth of expertise in a broad range of recreational off-road and traditional motorsports. MasterCraft's long standing reputation, combined with Impact's revolutionary product lines, make these two companies a perfect match further improving the safety of weekend warriors and racers alike!



Moab Photo Provided by Harry Wagner.

ANATOMY of a MASTERCRAFT SEAT

Constructed from mandrel bent and laser-notched .065 three-quarter inch tubing, all MasterCraft seats are expertly welded to exacting Mil-spec standards and feature either a flat strap or four-tab mount fully integrated into the frame. By incorporating the frame mounting straps, MasterCraft strengthened the overall integrity of the structure ensuring your seat can handle abuses ranging from weekend wheeling to extreme Baja racing. Finished with a high-resiliency fatigue fighting foam and fire retardant UV-treated upholstery, your MasterCraft seat has been extensively tested and validated to comply with all applicable seat criterion of the Federal Motor Vehicle Safety Standard. Don't settle for inferior construction – only a genuine MasterCraft seat offers this level of craftsmanship!



While comfort and safety on the trail is important, MasterCraft also expanded into a market where impact absorption and energy attenuation can quite literally mean the difference between life and death. As devoted patriots, Robbie Pierce and the team at MasterCraft are exceptionally proud of our work with the armed forces.

Developing and testing seating systems to exceed requirements outlined by stringent military standards is never an easy task. To that end, MasterCraft took on the challenge and delivered a line of energy-mitigating seats that perform remarkably well in a conflict environment. MasterCraft's Made in the U.S.A. defense seating and restraint systems have been used in US military combat vehicles such as the MRAP and LSAC for nearly a decade and have a proven track-record.

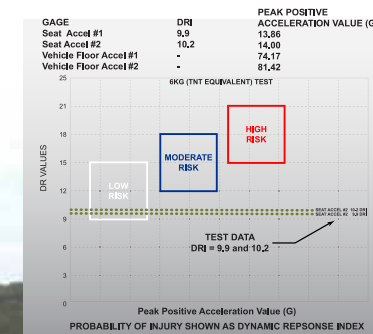

Independent tests have shown MasterCraft Safety's line of energy-attenuating defense seating provides an 84% reduction in force from a 50 "G" load live fire (blast) event; a force equal to that of 6kgs of explosive mass as outlined in the NATO Stanag 4569 2A standard. These are exactly the types of impacts that IEDs inflict on combat vehicles and why MasterCraft has devoted tremendous resources and technology towards developing safety solutions for our men and women serving overseas.



BLAST TESTED

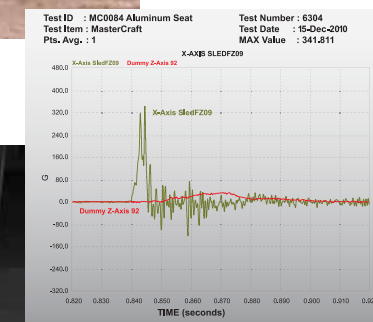

Independent tests indicated that MasterCraft Safety's line of defense seating provided remarkable and repeatable energy-attenuation during +Z axis impacts. The above graph indicates a massive 342G +Z-axis hit to the seat base resulting in only 34Gs of energy reaching the 50th percentile Hybrid III Anthropomorphic Test Device's instrumented pelvis. This test is representative of the extreme forces experienced by combat vehicles in conflict areas and demonstrative of MasterCraft's ability to mitigate enormous impact energy.



SLED TESTED

BAJA RS® PREMIUM RECLINING SUSPENSION SEAT

The first reclining suspension seat for off-road enthusiasts, the MasterCraft Baja RS® offers comfort, containment, safety and fatigue-fighting ergonomics perfect for exploring Moab or taking on your grueling everyday commute. Designed with both form and function in mind, MasterCraft's Baja RS® seat features a mid-rise side bolster for ease of ingress and egress while also providing superior containment; even during the most spirited adventures. Featuring a durable yet comfortable UV-resistant Marquesa fabric, the Baja RS® also offers superior lumbar support with our proprietary high-resiliency foam offering the ultimate in energy attenuation and fatigue-fighting comfort. The machined billet lever and 9-position reclining mechanism provide years of trouble-free use while the integrated seat belt slots and belt loops provide harness guides ensuring your five-point belts stay in place. With available "creature comfort" options such as seat heaters, lumbar support, seat pockets and Camelbak™ pouches, the MasterCraft Baja RS® provides the ultimate seat balancing everyday practicality with features specifically designed for off-road use. Additionally, MasterCraft seats are sled and drop-tested and exceeds Federal Motor Vehicle Safety Standard (FMVSS) requirements. The Baja RS® shares the same flexibility in mounting as our popular Rubicon® series seat and is the perfect addition to your Jeep® JK, TJ, CJ and YJ as well as Ford Bronco, Toyota Tacoma, and more. Available in five standard color combinations and five Dirt Sport color combos, the MasterCraft Baja RS® will enhance both the comfort and interior of your vehicle!

- 9-Position Reclining Seat from Forward Tilt to Full Recline
- Left (Driver) or Right (Passenger) Recliner Mechanism Location
- High Resiliency Foam for Superior Energy Attenuation & Comfort
- Precision Crafted Laser Cut Tubular Frame Construction
- Machined Billet Lever and Heavy Duty Reclining Mechanism for Superior Performance
- Durable yet Comfortable UV-Treated Marquesa Fabric available in 10 Color Styles
- 5-Point Seat Belt Slots (with additional seatbelt loops to secure harnesses in place)
- Many Available Options such as Seat Heaters, Lumbar Support, Seat Pockets and More
- Tested and Validated to Comply with Applicable FMVSS
- Moab and Rubicon Trail Tested and Baja Proven
- Direct Bolt-In Application for Most Jeep® CJ-5s, all Jeep® CJ-7 & YJs
- Other Vehicle Fitments Available when Used with MasterCraft Safety Supplied Mounting Kits. See Page 27 for More Info.
- Hip Containment: 6.5-inches

MADE IN THE USA

BRS COVER	BLACK w/RED	BLACK w/BLUE	ALL BLACK	SMOKE w/GRAY	TAN w/BROWN
RECLINER LEVER LEFT - FIXED HEADREST	504012	504013	504004	504007	504018
RECLINER LEVER RIGHT - FIXED HEADREST	506012	506013	506004	506007	506018
RECLINER LEVER LEFT - ADJUSTABLE HEADREST	512012	512013	512004	512007	512018
RECLINER LEVER RIGHT - ADJUSTABLE HEADREST	514012	514013	514004	514007	514018
DIRTSPOUT COVER	BLACK w/RED	BLACK w/BLUE	ALL BLACK	SMOKE w/GRAY	TAN w/BROWN
RECLINER LEVER LEFT - FIXED HEADREST	504102	504103	504104	504107	504108
RECLINER LEVER RIGHT - FIXED HEADREST	506102	506103	506104	506107	506108
RECLINER LEVER LEFT - ADJUSTABLE HEADREST	512102	512103	512104	512107	512108
RECLINER LEVER RIGHT - ADJUSTABLE HEADREST	514102	514103	514104	514107	514108

**The Dirt Sport Cover is designed to add styling while reinforcing areas of the seat that experience a little more wear and tear. The Dirt Sport insets feature our durable reinforced vinyl with a carbon-fiber look that meets both form and function.*

CUSTOM ADD-ON OPTIONS	* See Page 28
ADD PASSENGER'S SIDE - LUMBAR LEFT	600001
ADD DRIVER'S SIDE - LUMBAR RIGHT	600002
ADD ELECTRONIC SEAT HEATER (Installed)	600006
ADD REAR SEAT POCKET	600008
ADD CAMELBAK POCKET	600060
ADD CAMELBAK SET (Pocket, Reservoir & Tube included)	600061



* For Full Dimensions See Pg. 38



RECLINER:
9-Position Recliner
From Forward Tilt
to Full Recline

BRS COVER:
Black
w/Black Center
and Red Sides

BRS COVER:
Black
w/Black Center
and Blue Sides

BRS COVER:
Black
w/Black Center
and Black Sides

BRS COVER:
Smoke
w/Black Center
and Gray Sides

BRS COVER:
Desert Tan
w/Black Center
and Brown Haze Sides



DIRTSPOUT COVER:
Black
w/Red Center
and Red Sides

DIRTSPOUT COVER:
Black
w/Blue Center
and Blue Sides

DIRTSPOUT COVER:
Black
w/Black Center
and Black Sides

DIRTSPOUT COVER:
Smoke
w/Gray Center
and Gray Sides

DIRTSPOUT COVER:
Desert Tan
w/Brown Haze Center
and Brown Haze Sides



ADJUSTABLE HEADREST:
Adjustable Headrest
Shown on the All Black
DirtSport Cover.

SAHARA™ BUDGET RECLINING SUSPENSION SEAT

MasterCraft is never willing to compromise on safety, however we also recognize that different households have varying budgets to devote to their passions and hobbies. It was with this thinking in mind that the Sahara™ was created.

The Sahara™ seat offers many of the same features and qualities that made the MasterCraft brand a mainstay amongst off-road and Jeep enthusiasts. The Sahara™ is a true suspension seat designed from the ground-up featuring precision-crafted tubular construction, an open-mesh liner, and high resiliency foam for comfort, longevity, and the durability MasterCraft Safety is famous for.

The MasterCraft Safety Sahara™ is a budget-minded import version based on our legendary Baja RS seat. The Sahara™ is only offered in black, with only two part numbers (the only difference is which side the reclining lever is on).

The Sahara™ also uses the same mounting tabs and installation kits as the Baja RS, so no additional development costs were required. These savings are passed on, allowing MasterCraft to utilize high-end materials like the wear-resistant proprietary UV-treated seat cover fabric while maintaining a reasonable price.

- Direct Bolt-in Application for Most CJ5s, all CJ7 and YJs
- Other Vehicle Fitments Available when Used with MasterCraft Safety Supplied Mounting Kits. See Page 27 for More Info.
- 9-Position Reclining Seat from Tilt Forward to Full Recline
- Left (Driver) or Right (Passenger) Recliner Mechanism Location
- Energy Attenuating Foam for Reduced Fatigue and Increased Comfort
- Machined Billet Lever and Heavy Duty Reclining Mechanism for Superior Performance
- Durable yet Comfortable UV-Treated Fabric
- Five Point Seat Belt Slots and Loops to Secure Belts
- Tested and Validated to Comply with Applicable FMVSS
- Hip Containment: 6.5-Inches
- Available Only in Black

	ALL BLACK	
RECLINER LEVER LEFT	544004	
RECLINER LEVER RIGHT	546004	
PAIR	525300	



* For Full Dimensions See Pg. 38



ROCKSTAR GARAGE'S 1973 BRONCO RESTO-MOD BUILD WITH BAJA RS SEATS WITH DIRT SPORT COVER.



MARK HAINES' JEEP JK BUILD WITH BAJA RS SEATS w/DIRTSPOUT COVER.



RUBICON® PREMIUM SUSPENSION SEAT

The MasterCraft Safety Rubicon® is a fixed-back seat and is the ideal choice for off-roaders wanting the benefits and comfort of a true suspension seat while not requiring a reclining function. The Rubicon® features the same high-quality precision craftsmanship that has made MasterCraft a trusted household name for Jeep® and off-road enthusiasts worldwide. Featuring a three-quarter rise bolster, the Rubicon® offers 6.5-inches of hip containment and 5.5-inches of shoulder containment keeping you safely nestled into your seat, even while maneuvering the most challenging obstacle or conquering the seat's namesake; the "Rubicon Trail."

MasterCraft's Rubicon® also offers superior lumbar support with our proprietary high-resiliency foam providing unsurpassed energy attenuation and fatigue-fighting comfort. The easy-care Marquesa fabric features ultra-violet resistance and durability providing years of trail use and enjoyment. With available "creature comfort" options such as seat heaters, lumbar support, seat pockets and Camelbak™ pouches; the MasterCraft Rubicon® provides the ultimate seat designed with the rigors of trail-riding and the daily commute in mind. The Rubicon® bolts directly into most Jeep® CJ-5 and all CJ-7 and YJ models making it an excellent interior upgrade for many applications. The Jeep® TJ, XJ and JK models are also bolt-in when used with our vehicle specific mounting kits. MasterCraft's Rubicon® also works well with the Suzuki Samurai and Toyota Tacoma in addition to many of the popular overlanding vehicles. All MasterCraft seat models have been extensively sled and drop-tested and exceeds Federal Motor Vehicle Safety Standard (FMVSS) requirements so you can wheel your vehicle with confidence. Available in five standard color combinations, the MasterCraft Rubicon® will not only improve your vehicle's ride and comfort, it will compliment and enhance the interior as well!

- Race Inspired Off-Road Seat
- Three-Quarter Rise Bolster for Superior Containment
- High Resiliency Foam for Exceptional Energy Attenuation and Comfort
- Precision Crafted Laser Cut Tubular Frame Construction
- Secondary Suspension Straps for Additional Support and Fatigue-Fighting Comfort
- 5-Point Seat Belt Slots (with additional seatbelt loops to secure harnesses in place)
- Tested and Validated to Comply with Applicable FMVSS
- Direct Bolt-In Application for Most Jeep® CJ-5s, all Jeep® CJ-7 & YJs
- Other Vehicle Fitments Available when Used with MasterCraft Safety Supplied Mounting Kits. See Page 27 for More Info.
- Hip Containment: 6.5-inches
- Upper Torso Containment: 5.5-inches

MADE IN THE USA 

BRS COVER	BLACK w/RED	BLACK w/BLUE	ALL BLACK	SMOKE w/GRAY	TAN w/BROWN
	524102	524103	524104	524107	524108

CUSTOM ADD-ON OPTIONS		* See Page 28
ADD PASSENGER'S SIDE - LUMBAR LEFT	600001	
ADD DRIVER'S SIDE - LUMBAR RIGHT	600002	
ADD ELECTRONIC SEAT HEATER (Installed)	600006	
ADD REAR SEAT POCKET	600008	
ADD CAMELBAK POCKET	600060	
ADD CAMELBAK SET (Pocket, Reservoir & Tube included)	600061	



Black w/Black Center and Red Sides

Black w/Black Center and Blue Sides

Black w/Black Center and Black Sides

Smoke w/Black Center and Gray Sides

Desert Tan w/Black Center and Brown Haze Sides



1970 FORD BRONCO BUILD WITH FULL CUSTOM RUBICONS WITH DIRT SPORT COVER; OWNED BY JOHN COLE OF ELITE AUTO.



* For Full Dimensions See Pg. 38

NOMAD™ BUDGET SUSPENSION SEAT

The MasterCraft Safety Nomad™ is a budget-minded import version based on our legendary fixed-back Rubicon®. Designed from the ground-up as a true suspension seat, the Nomad™ features precision-crafted tubular construction, an open-mesh liner, and high resiliency foam for comfort, longevity and durability. The Nomad™ offers many of the same features and qualities that made MasterCraft a cornerstone brand among off-road and Jeep® enthusiasts. Mounting and installation is easy too; the seat will install in the same applications as our popular Rubicon®. The easy-care, wear-resistant proprietary UV-treated seat cover fabric ensures your seat will last many seasons. Just like all MasterCraft Safety seating, the value-packed Nomad™ has been extensively sled and drop-tested and exceeds Federal Motor Vehicle Safety Standard (FMVSS) requirements so you and your family can have confidence in your equipment on the trail. The MasterCraft Safety Nomad™ works well in the Ford Ranger and Bronco, Jeep® Cherokee as well as other Jeep® models such as the JK, TJ, YJ, and CJ-5 and CJ-7 models. Available in black only.

- True Suspension Off-Road Seat
- Three-Quarter Rise Bolster for Superior Containment
- High Resiliency Foam for Enhanced Energy Attenuation and Comfort
- Precision Crafted Tubular Frame Construction
- Secondary Suspension Straps for Additional Support and Fatigue-Fighting Comfort
- 5-Point Seat Belt Slots
- Tested and Validated to Comply with Applicable FMVSS
- Hip Containment: 6.5-inches
- Upper Torso Containment: 5.5-inches
- Direct Bolt-in Application for most Jeep® CJ5s, all Jeep CJ7 & YJs
- Other Vehicle Fitments Available when Used with MasterCraft Safety Supplied Mounting Kits. See Page 27 for More Info.

	ALL BLACK
SINGLE SEAT	530004
PAIR	525200



* For Full Dimensions See Pg. 38

SPORTSMAN™ PREMIUM SUSPENSION SEAT

A favorite seating choice among long-time MasterCraft loyalists, the Sportsman™ cut its teeth pre-running Baja and chasing down racecars in the Nevada desert. Due to its mounting design and seat angle, the Sportsman™ is ideal for early or late model Broncos and it adapts just as easily to the Ford Ranger, Toyota Pickups, and Chevy K5 Blazer and GMC S-Series. The Sportsman™ also fits nicely in the full-size Ford, Chevy and Dodge trucks and is the perfect seat for the everyday commute or the terrain of Baja.

The Sportsman™ offers superior fatigue-fighting comfort and energy-attenuation through the use of MasterCraft's exclusive military grade high-density closed-cell foam. The easy-care Marquesa fabric provides ultra-violet resistance and extreme wear-test durability ensuring your MasterCraft Sportsman™ can withstand the abuses of your desert wanderings. Additional options such as seat heaters and lumbar support offer much needed warmth and comfort during long nights chasing Baja while the optional seat back pockets or Camelbak™ pouch provide compartments to stash essentials or offer much needed hydration. Whether you're out weekend 4-wheeling, pre-running, or trying to get a spare part to a SCORE Trophy Truck® in the middle of Baja, the Sportsman™ is the seat you can trust your body to.

- Race Inspired Off-Road Seat
- Three-Quarter Rise Bolster for Superior Containment
- High Resiliency Foam for Exceptional Energy Attenuation and Comfort
- Precision Crafted Laser Cut Tubular Frame Construction
- Secondary Suspension Straps for Additional Support and Fatigue-Fighting Comfort
- 5-Point Seat Belt Slots (with additional seatbelt loops to secure harnesses in place)
- Tested and Validated to Comply with Applicable FMVSS
- Hip Containment: 6.5-inches
- Upper Torso Containment: 5.5-inches

MADE IN THE USA

BRS COVER	BLACK w/RED	BLACK w/BLUE	ALL BLACK	SMOKE w/GRAY	TAN w/BROWN
	576202	576203	576204	576207	576208

CUSTOM ADD-ON OPTIONS	* See Page 28
ADD PASSENGER'S SIDE - LUMBAR LEFT	600001
ADD DRIVER'S SIDE - LUMBAR RIGHT	600002
ADD ELECTRONIC SEAT HEATER (Installed)	600006
ADD REAR SEAT POCKET	600008
ADD CAMELBAK POCKET	600060
ADD CAMELBAK SET (Pocket, Reservoir & Tube included)	600061



Black w/Black Center and Red Sides
Black w/Black Center and Blue Sides
Black w/Black Center and Black Sides



Smoke w/Black Center and Gray Sides
Desert Tan w/Black Center and Brown Haze Sides



* For Full Dimensions See Pg. 38

ORIGINAL™ PREMIUM SUSPENSION SEAT

Just as the name implies, the MasterCraft Original® was designed in 1970 by MasterCraft's founder, Jack Miller, and quickly became the suspension seat of choice for the off-road racing community. While the MasterCraft product line has evolved over the last four decades, the redesigned Original® continues to be a must-have product among the Sand Sport crowd.

The Original® is a low-profile suspension seat designed with four gusseted vertical tabs for mounting. At the request of our family-oriented customers and the Sand Car manufacturers, we were asked to bring back our "Original" suspension seat for recreational sand buggies and sand rails. We agreed, but first this versatile seat had to undergo a few design changes as the sand cars of today are much faster than in 1970 when the first Original® was introduced. In order to provide a seat that can endure the rigors of the extreme sand market, we started by strengthening the four vertical mounting tabs and integrating these key structural components into the seat frame. MasterCraft then modified the seat design to allow more room in the hip area as an extra measure of comfort and during extreme runs in Glamis or Dumont Dunes. With available "creature comfort" options such as seat heaters, lumbar support, seat pockets and Camelbak™ pouches, the MasterCraft Original® provides unparalleled options perfect for sand sports.

- Four Vertical Tab Gusseted Mounting
- Low Profile Suspension Seat
- 5-Point Seat Belt Slots
- Loops to Secure Restraint Harnesses in Place
- Tested and Validated to Comply with Applicable FMVSS
- Hip containment: 7-inches
- Upper torso containment: 5.5-inches
- Sitting Level Height from Floor: 3-inches
- Mounting Area: 14-inch Wide and 18-inch Front to Back
- Available in Black or Gray

MADE IN THE USA 

BOX STITCH COVER	ALL BLACK	SMOKE w/GRAY
	576019	576020

CUSTOM ADD-ON OPTIONS		* See Page 28
ADD PASSENGER'S SIDE - LUMBAR LEFT	600001	
ADD DRIVER'S SIDE - LUMBAR RIGHT	600002	
ADD ELECTRONIC SEAT HEATER (Installed)	600006	
ADD REAR SEAT POCKET	600008	
ADD CAMELBAK POCKET	600060	
ADD CAMELBAK SET (Pocket, Reservoir & Tube included)	600061	



Black w/Black Center and Black Sides

Smoke w/Gray Center and Gray Sides

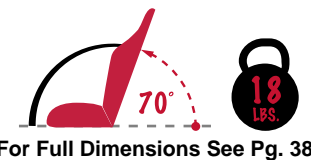

* For Full Dimensions See Pg. 38



ROD HALL'S 1969 STROPPE BRONCO WITH PRO4 SEATS.



BED RUG'S JEEP TJ BUILD WITH BAJA RS SEATS.

COMPASS™ PREMIUM SUSPENSION UTV SEAT

Upgrade the comfort of your Polaris® RZR® with MasterCraft's Compass™ seat designed to endure the rigors and versatility of the UTV market. Specifically constructed for the Polaris® RZR®, MasterCraft's Compass™ is a direct bolt-in replacement seamlessly adapting to the factory OEM mounts while retaining a high-back seat design with integrated five-point harness slots for added support. The MasterCraft Compass™ fits both the driver and passenger front and rear seat positions and requires no special tools or additional mounts for installation. Upholstered with a high-performance marine-grade vinyl, the MasterCraft Compass™ offers easy cleanup and maintenance, making this seat the ideal interior upgrade for your Polaris® RZR® side-by-side utility vehicle. Constructed from laser-notched, CNC bent tubing, the Compass™ seat is precision-crafted from the ground up and features only the highest quality materials and workmanship that made MasterCraft a main-stay among recreational and off-road racing enthusiasts alike. Finished with MasterCraft's military grade energy-attenuating impact foam, the Compass™ offers exceptional comfort and fatigue-fighting lumbar support so you and your family can enjoy the versatility of your UTV all day long.

- Direct Bolt-In Replacement for the Polaris® RZR® models (up to 900cc) and RZR 1000 Model
- Includes Integrated Five Point Seat Belt Slots
- Upholstered with Easy-to-Clean Marine Grade Vinyl
- Features a Hand Slot Allowing Easy Access to the Stock RZR Release Lever
- Also Includes MasterCraft's Rock Catcher Preventing Debris From Collecting on the Seat Cushion
- High Resiliency Foam for Enhanced Energy Attenuation and Comfort
- Tested and Validated to Comply with Applicable FMVSS
- Hip Containment: 5-inches
- Sitting Level Height from Floor: 3-inches

MADE IN THE USA

	BLACK w/SILVER PIPING	BLACK w/ORANGE PIPING	BLACK w/RED PIPING
650cc-950cc (08-15)	573204	573206	573202
1000cc (12-15)	573304	573306	573302

* 650cc-950cc Models Mount using OE Front or Rear Hardware
* 1000cc Models Mount using OE hardware and Maintains Factory Front Adjusters

CUSTOM ADD-ON OPTIONS		* See Page 28
ADD PASSENGER'S SIDE - LUMBAR LEFT	600001	
ADD DRIVER'S SIDE - LUMBAR RIGHT	600002	
ADD ELECTRONIC SEAT HEATER (Installed)	600006	
ADD REAR SEAT POCKET	600008	
ADD CAMELBAK POCKET	600060	
ADD CAMELBAK SET (Pocket, Reservoir & Tube included)	600061	



Black w/Silver Piping Black w/Orange Piping Black w/Red Piping



72°
20 LBS.
* For Full Dimensions See Pg. 38

PWR SPORT™ PREMIUM SUSPENSION UTV SEAT

Upgrade the comfort of your side-by-side with MasterCraft's PWRSport™ seat designed to endure the rigors and versatility of the UTV market. Specifically constructed for the Yamaha Rhino® and Kawasaki Teryx®, MasterCraft's PWRSport™ is a direct bolt-in replacement seamlessly adapting to the factory OEM mounts while retaining a full-size seat profile. Offered with options such as seat heaters, lumbar support, seat pockets or Camelbak™ pouch, the PWRSport™ is upholstered with a high-performance UV treated Marquessa fabric making this the ideal interior upgrade for your side by side. Featuring laser-notched tube construction, the PWRSport™ is finished with MasterCraft's military grade energy-attenuating impact foam offering improved comfort and fatigue-fighting lumbar support. The MasterCraft PWRSport™ also includes integrated shoulder harness guide loops and anti-sub and lap belt slots keeping your five-point restraints ideally positioned. The three-quarter-rise bolster offers ease of ingress and egress while the 7-inches of hip containment keep you positioned in your seat during spirited adventures. The MasterCraft PWRSport™ fits both the driver and the passenger position of the Yamaha Rhino® and Kawasaki Teryx® UTVs and requires no special tools or additional mounts for installation. MasterCraft also offers a matching headrest pad cover (sold separately). The PWRSport™ will fit with the Yamaha Rhino® factory seatbelt.

- Direct Bolt-In Replacement for the Yamaha Rhino® and Kawasaki Teryx®
- Three-Quarter Rise Bolster for Superior Containment
- Easy Care UV Treated Marquessa Fabric
- High Resiliency Foam for Enhanced Energy Attenuation & Comfort
- Includes Anti-Sub and Lap Seat Belt Slots
- Shoulder Harness Loops to Secure Harness Bar Restraints in Place
- Tested and Validated to Comply with Applicable FMVSS
- Hip Containment: 7-inches

MADE IN THE USA

BRS COVER	BLACK w/RED	BLACK w/BLUE	ALL BLACK	SMOKE w/GRAY
NO Headrest	573002	573005	573004	573014
WITH Headrest	574002	574005	574004	574014

CUSTOM ADD-ON OPTIONS		* See Page 28
ADD PASSENGER'S SIDE - LUMBAR LEFT	600001	
ADD DRIVER'S SIDE - LUMBAR RIGHT	600002	
ADD ELECTRONIC SEAT HEATER (Installed)	600006	
ADD REAR SEAT POCKET	600008	
ADD CAMELBAK POCKET	600060	
ADD CAMELBAK SET (Pocket, Reservoir & Tube included)	600061	



Black w/Black Center and Red Sides Black w/Black Center and Blue Sides
Black w/Black Center and Black Sides Smoke w/Black Center and Gray Sides



70°
20 LBS.
* For Full Dimensions See Pg. 38



ROBBY GORDON'S SPEED ENERGY
POLARIS RZR-1000 WITH COMPASS SEATS.



RED DOT ENGINEERING'S POLARIS RZR-900
WITH COMPASS SEATS.



UTV UNDERGROUND POLARIS RZR 900
WITH COMPASS SEATS.



RJ ANDERSON'S POLARIS RZR XP1K
FULL RACE-EQUIPPED.

3G™ & 3G-4™ PREMIUM SUSPENSION RACE SEAT

Originally developed to attenuate the high-speed and violent impacts common to short course off-road racing, MasterCraft Safety's 3G™ is the only race-proven suspension seating system constructed from laser-notched 4130 (chromoly) tubing for superior structural integrity. Designed with input from champion racers, the MasterCraft 3G™ offers improved lateral support while the 10-inch deep-sided bolster provides exceptional hip containment, so important in today's competition. The removable bottom cushion allows for speedy seat customization during driver changes, as well as easy cleanup after the race. Borrowing technology from our military line of blast mitigating seats, the MasterCraft 3G™ provides unparalleled attenuating properties, reducing impact energies and lumbar stress by 84% (as shown in independent lab testing required of defense suppliers). Featuring flame resistant foam and upholstery, the materials used in the manufacture of MasterCraft's 3G™ meet and exceed FMVSS 302 and California's TB117 fire safety requirements. Finished with our exclusive Dirt Sport Cover, this popular enhancement reinforces common wear areas of the seat with our carbon fiber patterned vinyl. MasterCraft Safety's 3G™ installs using a reinforced, heavy-duty flat strap mount (four tab mount also available, specify when ordering). Additional upgrades such as seat heaters and lumbar support offer much needed warmth and comfort during long stretches of SCORE Baja racing while optional seat back pockets provide compartments to stash essentials. Looking for a hydration solution for your racecar? Be sure to check out our Camelbak™ pouch option!

- 5-Point Seat Belt Slots
- Flat Strap Mount (Four Tab Mount Available with Our 3G-4, Please Specify)
- Deep-Sided Race Seat with 10-inches of Hip Containment
- Improved Lateral Support with 8-inches of Upper Torso Containment
- Laser Notched 4130 (Chromoly) Tubular Frame Construction
- High Resiliency Foam for Exceptional Energy Attenuation
- Independent Lab Tests Indicate an 84% Reduction in Impact Energy
- Secondary Suspension Straps Provide Unparalleled Support
- Manufactured Using Flame Resistant Foam and Upholstery
- Removable Cushion for Driver Customization and Easy Clean-Up
- Size: 36-Inches Tall x 22-Inches Wide x 28-Inches Deep
- Mounting Area: 15-Inches Front to Back and 13.5-Inches Wide On Center
- Sitting Level Height from Floor: 4-Inches

MADE IN THE USA 

3G™ - FLAT STRAP MOUNT	BLACK w/RED	BLACK w/BLUE	ALL BLACK	SMOKE w/GRAY
STANDARD WIDTH	568012	568013	568014	568019
1" WIDER	568022	568023	568024	568029
2" WIDER	568032	568033	568034	568039

3G™ - 4-TAB MOUNT	BLACK w/RED	BLACK w/BLUE	ALL BLACK	SMOKE w/GRAY
STANDARD WIDTH	572012	572013	572014	572019
1" WIDER	572022	572023	572024	572029
2" WIDER	572032	572033	572034	572039

CUSTOM ADD-ON OPTIONS		* See Page 28
ADD PASSENGER'S SIDE - LUMBAR LEFT	600001	
ADD DRIVER'S SIDE - LUMBAR RIGHT	600002	
ADD ELECTRONIC SEAT HEATER (Installed)	600006	
ADD REAR SEAT POCKET	600008	
ADD CAMELBAK POCKET	600060	
ADD CAMELBAK SET (Pocket, Reservoir & Tube included)	600061	

For applications requiring a four-tab vertical mount, MasterCraft Safety also offers our 3G-4 seat. Offering all the same features and benefits as our standard flat strap 3G™ seat, the 3G-4 provides flexibility in mounting to a roll-cage with the vertical four tab mount. Integrating the mounting tabs into the seat frame allowed MasterCraft to strengthen the overall integrity of these key structural components, ensuring your seat frame can handle all the same abuses as your chassis! Don't settle for inferior construction – only a genuine MasterCraft seat offers this level of craftsmanship!



Black w/Red Center and Red Sides

Black w/Blue Center and Blue Sides

Black w/Black Center and Black Sides

Smoke w/Gray Center and Gray Sides



SCORE 1/2-1600 DRIVEN BY ERIC SHEETZ & JUSTIN HERRMANN; EQUIPPED WITH 3G SEATS.



* For Full Dimensions See Pg. 38

PROSEAT™ & PRO4™ PREMIUM SUSPENSION RACE SEAT

MasterCraft® Safety's ProSeat™ has been the standard for reliability and comfort in competitive off-road race vehicles and luxury pre-runners for over a decade. Constructed from laser-notched 4130 (chromoly) tubing for superior structural integrity and offering a "flat strap" installation, MasterCraft's ProSeat™ incorporates a higher-rise bolster for more than 9.5-inches of hip containment. Just like our top-of-the-line 3G™, the ProSeat™ features MasterCraft's proprietary energy attenuating high-resiliency foam reducing impact injuries and lumbar stress by more than 84%. Featuring flame resistant foam and upholstery, the materials used in the manufacture of MasterCraft's ProSeat™ meet and exceed FMVSS 302 and California's TB117 fire safety requirements. Additional upgrades are available such as a removable cushion for ease of clean-up and customized fitment during driver changes, while seat heaters and lumbar support offer much needed warmth and comfort during long stretches of SCORE Baja racing. Optional seat back pockets provide compartments to stash essentials or you can opt for the Camelbak™ pouch for a much needed hydration solution for your racecar.

- 5-Point Seat Belt Slots
- Flat Strap Mount (Four Tab Mount Available with Our Pro-4, Please Specify)
- Deep-Sided Race Seat with 9.5-inches of Hip Containment
- Laser Notched 4130 (Chromoly) Tubular Frame Construction
- High Resiliency Foam for Exceptional Energy Attenuation
- Independent Lab Tests Indicate an 84% Reduction in Impact Energy
- Secondary Suspension Straps Provide Unparalleled Support
- Manufactured Using Flame Resistant Foam and Upholstery
- Available with a Removable Cushion for Driver Customization and Easy Clean-Up
- Size: 35-Inches Tall x 22-Inches Wide x 28-Inches Deep
- Mounting Area: 15-Inches Front to Back and 13-Inches Wide On Center
- Sitting Level Height from Floor: 5-Inches

MADE IN THE USA

FIXED CUSHION-BRS COVER

PROSEAT™ - FLAT STRAP MOUNT	BLACK w/RED	BLACK w/BLUE	ALL BLACK	SMOKE w/GRAY
STANDARD WIDTH	560012	560013	560014	560019
1" WIDER	560112	560113	560114	560119
2" WIDER	560212	560213	560214	560219

REMOVABLE CUSHION-BRS COVER

PROSEAT™ - FLAT STRAP MOUNT	BLACK w/RED	BLACK w/BLUE	ALL BLACK	SMOKE w/GRAY
STANDARD WIDTH	561012	561013	561014	561019
1" WIDER	561112	561113	561114	561119
2" WIDER	561212	561213	561214	561219

FIXED CUSHION-BRS COVER

PRO4™ - 4-TAB MOUNT	BLACK w/RED	BLACK w/BLUE	ALL BLACK	SMOKE w/GRAY
STANDARD WIDTH	564012	564013	564014	564019
1" WIDER	564112	564113	564114	564119
2" WIDER	564212	564213	564214	564219

REMOVABLE CUSHION-BRS COVER

PRO4™ - 4-TAB MOUNT	BLACK w/RED	BLACK w/BLUE	ALL BLACK	SMOKE w/GRAY
STANDARD WIDTH	565012	565013	565014	565019
1" WIDER	565112	565113	565114	565119
2" WIDER	565212	565213	565214	565219

CUSTOM ADD-ON OPTIONS		* See Page 28
ADD PASSENGER'S SIDE - LUMBAR LEFT	600001	
ADD DRIVER'S SIDE - LUMBAR RIGHT	600002	
ADD ELECTRONIC SEAT HEATER (Installed)	600006	
ADD REAR SEAT POCKET	600008	
ADD CAMELBAK POCKET	600060	
ADD CAMELBAK SET (Pocket, Reservoir & Tube included)	600061	



FLAT STRAP MOUNT

TAB MOUNT

ProSeat™ Uses Our FlatStrapMount™ Technology

Pro4™ Uses Our TabMount™ Technology. Fits any 14" x 18" Four Vertical Tab Mounting System



Black w/Black Center and Red Sides

Black w/Black Center and Blue Sides



Black w/Black Center and Black Sides

Smoke w/Gray Center and Gray Sides



WALKER EVANS' ALUMICRAFT-BUILT CLASS 1 CAR WITH PRO4 SEATS.

For applications requiring a four-tab vertical mount, MasterCraft Safety also offers our Pro4™ seat. Offering all the same features and benefits as our standard flat strap ProSeat™ seat, the Pro4™ provides flexibility in mounting to a roll-cage with the vertical four tab mount. Integrating the mounting tabs into the seat frame allowed MasterCraft to strengthen the overall integrity of these key structural components, ensuring your seat frame can handle all the same abuses as your chassis! Don't settle for inferior construction – only a genuine MasterCraft seat offers this level of craftsmanship!



HS-1 by **IMPACT** HARDSHELL RACE SEAT

Impact's HS-1 is a top-of-the-line performance seat purposely engineered to withstand torsional stress and abuses common to off-road competition. Constructed from 100% epoxy-reinforced infused carbon fiber, the Impact HS-1 features an embedded single-piece laser cut and drilled mounting bracket providing continuously connected support, strength, and rigidity. Precision alignment of the restraint and mount openings is achieved through 5-axis CNC trimming. This extraordinary level of craftsmanship ensures uniformity throughout the seat resulting in the repeatable accuracy chassis builders and prep crews value. The HS-1's lightweight ergonomic design is a product of CAD engineering coupled with real world input from renowned chassis builders and racers. Finished with fire retardant high resiliency foam for superior energy attenuation, the Impact HS-1 offers improved comfort and support over competitive seats on the market. Upholstered with a non-slip and heavy-duty 300,000 double-rub abrasion and fire resistant fabric specially engineered to endure the extreme abuses of Baja, the HS-1 is the ideal balance of rugged and refined. Black only, replacement seat covers and cushions are readily available.

- Infused Carbon Fiber with Epoxy Reinforcement
- 5-Axis CNC Trimmed for Precision Restraint and Mount Alignment
- Single-Piece Laser-Cut and Drilled Mounting Bracket
- Fire Retardant, High Resiliency Foam for Enhanced Energy Attenuation
- Non-Slip, Abrasion Resistant and Fire Retardant Upholstery
- Includes Anti-Sub and Lap Seat Belt Slots
- Hip Containment: 14-inches

MADE IN THE USA

	ALL BLACK
STANDARD HEIGHT	60000001
3" TALLER	60000002

REPLACEMENT PARTS	
REPLACEMENT SEAT COVER (Std Height Seat)	61000001
REPLACEMENT SEAT COVER (3" Taller Seat)	61000002
REPLACEMENT LOWER CUSHION	61000003
REPLACEMENT UPPER CUSHION	61000004
SHOULDER BELT OPENING RINGS	61000005
LAP BELT OPENING RINGS	61000006

* Replacement Seat Covers Include Cushions and Replacement Trim Pieces.

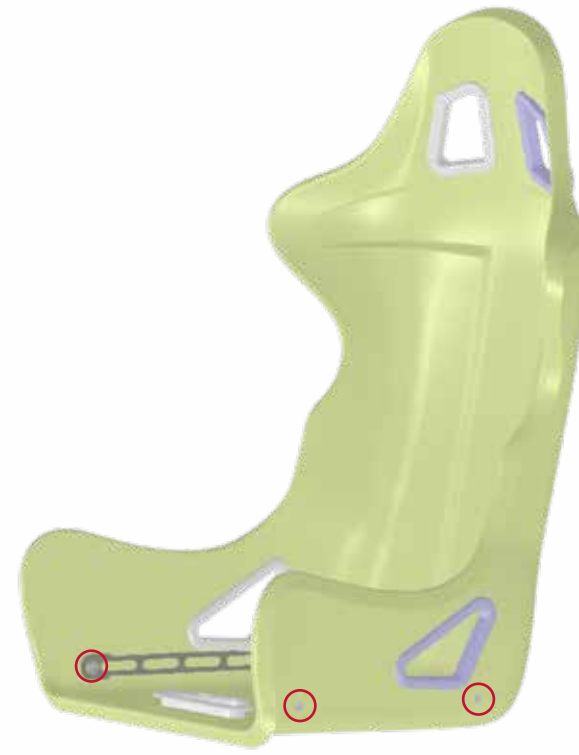

The seat mount openings for the HS-1 are precisely drilled on a 5-axis CNC providing for a consistently patterned installation for accurate mounting. The single-piece laser cut and drilled mounting bracket is fully integrated and bonded with the seat resulting in improved torsional strength as well as mount holes and weld nuts that maintain a continuous tolerance and do not wallow out over time.



MANGO RACING'S GARY MAGNESS CONQUERS THE SILT AT THE 2014 SCORE BAJA 1000.



C.J GREAVES TACKLING ANOTHER TORC SERIES RACE IN HIS PRO2 TRUCK.

TSCO's GARY WEYHRICH RUNNING HIS TRICK TRUCK IN THE 2014 BITD MINT 400.



* For Full Dimensions See Pg. 38

* Measurements shown are for the standard height seat.

FACTORY FIT™ SLIP COVERS

UPGRADE YOUR OEM REAR BENCH

Looking to match your OE Jeep® rear bench seats to your new MasterCraft Baja RS® or Rubicon® front seats with minimal hassle and expense? Upgrade your factory OEM fold-and-tumble rear bench with MasterCraft's Factory Fit™ slip covers. Available in color combinations to match your Rubicon or Baja RS, the Factory Fit slipcovers are an inexpensive and hassle-free way to complete your Jeep's interior.

MADE IN THE USA 

JEEP JK '13-'15, 2 DOOR	BLACK w/RED	BLACK w/BLUE	ALL BLACK	SMOKE w/GRAY	TAN w/BROWN
STANDARD BRS STITCH	702542	702543	702544	702547	702548
DIRTSPORT STITCH PATTERN	702552	702553	702554	702557	702558
JEEP JK '13-'15, 4 DOOR	BLACK w/RED	BLACK w/BLUE	ALL BLACK	SMOKE w/GRAY	TAN w/BROWN
STANDARD BRS STITCH	702562	702563	702564	702567	702568
DIRTSPORT STITCH PATTERN	702572	702573	702574	702577	702578

* JK Slip Covers include Adjustable Headret Covers.

JEEP JK '11-'12, 2 DOOR	BLACK w/RED	BLACK w/BLUE	ALL BLACK	SMOKE w/GRAY	TAN w/BROWN
STANDARD BRS STITCH	702463	712456	702457	702458	702464
DIRTSPORT STITCH PATTERN	702502	702503	702504	702507	702508
JEEP JK '11-'12, 4 DOOR	BLACK w/RED	BLACK w/BLUE	ALL BLACK	SMOKE w/GRAY	TAN w/BROWN
STANDARD BRS STITCH	702474	712467	702468	702469	702475
DIRTSPORT STITCH PATTERN	702512	702513	702514	702517	702518

* JK Slip Covers include Adjustable Headrest Covers.

JEEP JK '07-'10, 2 DOOR	BLACK w/RED	BLACK w/BLUE	ALL BLACK	SMOKE w/GRAY	TAN w/BROWN
STANDARD BRS STITCH	702441	712434	702435	702436	702442
DIRTSPORT STITCH PATTERN	702522	702523	702524	702527	702528
JEEP JK '07-'10, 4 DOOR	BLACK w/RED	BLACK w/BLUE	ALL BLACK	SMOKE w/GRAY	TAN w/BROWN
STANDARD BRS STITCH	702452	712445	702446	702447	702453
DIRTSPORT STITCH PATTERN	702532	702533	702534	702537	702538

* JK Slip Covers include Adjustable Headrest Covers.

JEEP TJ '03-'06	BLACK w/RED	BLACK w/BLUE	ALL BLACK	SMOKE w/GRAY	TAN w/BROWN
STANDARD BRS STITCH	712402	712403	702404	702407	712408
DIRTSPORT STITCH PATTERN	700482	700483	700484	700487	700488
JEEP TJ '97-'02	BLACK w/RED	BLACK w/BLUE	ALL BLACK	SMOKE w/GRAY	TAN w/BROWN
STANDARD BRS STITCH	702212	702213	702204	702207	702218
DIRTSPORT STITCH PATTERN	700282	700283	700284	700287	700288

JEEP CJs AND YJs '65-'95	BLACK w/RED	BLACK w/BLUE	ALL BLACK	SMOKE w/GRAY	TAN w/BROWN
STANDARD BRS STITCH	702012	702013	702004	702007	702018
DIRTSPORT STITCH PATTERN	700082	700083	700084	700087	700088



2-DOOR JK - BENCH COVER
DIRTSPORT COVER:
Smoke w/Gray
Shown

4-DOOR JK - 60/40 SPLIT BENCH COVER
DIRTSPORT COVER:
Smoke w/Gray
Shown

DIRTSPORT COVER:
Black
w/Red Center
and Red Sides

* Black w/Blue,
Smoke w/Gray
and Tan w/Brown Haze
not shown.

DIRTSPORT COVER:
Black
w/Black Center
and Black Sides

ORIGINAL BENCH SEAT

PREMIUM SUSPENSION REAR BENCH

The MasterCraft Original Bench suspension seat is the ideal addition for recreational sand cars, buggies, and off-road vehicles. Designed so the rest of your gang can ride along in safety, the Original Bench features four gusseted vertical tabs for mounting and is three inches shorter front to back to allow more legroom for the rear passengers. Featuring 7-inches of hip containment, the Original Bench also offers the lap belt slots as well as anti-sub slots and shoulder harness loops for use with five-point belts. The MasterCraft Original Bench seat is available in standard 40-inch width.

- Lap & Anti-Sub Seat Belt Slots (with additional seatbelt loops to secure harnesses in place)
- Precision Crafted Laser Cut Tubular Frame Construction
- High Resiliency Foam for Superior Energy Attenuation & Comfort
- Durable UV-Treated Marquesa Fabric Designed to Match Front MasterCraft Seats
- Many Available Options such as Seat Heaters, Seat Pockets and More
- Federal Motor Vehicle Safety Standard Tested & Approved
- Size: 23-inches tall x 40-inches wide x 24-inches deep
- Mounting Area: 15-Inches Front to Back & 32-Inches Wide On Center
- Sitting Level Height from Floor: 4-Inches

MADE IN THE USA 

BOX STITCH COVER	ALL BLACK	SMOKE w/GRAY
ORIGINAL SHORTY BENCH	773004	773009

BENCH CUSTOM ADD-ON OPTIONS		* See Page 28
ADD ELECTRONIC SEAT HEATER (Installed)	600006 (x2)	
ADD REAR SEAT POCKET	600008 (x2)	
ADD CAMELBAK POCKET	600060 (x2)	
ADD CAMELBAK SET (Pocket, Reservoir & Tube included)	600061 (x2)	

* Please note, benches require two of each seat option.



Black
w/Black Center
and Black Sides



Smoke
w/Gray Center
and Gray Sides

* For Full Dimensions See Pg. 38



Black
w/Black Center
and Red Sides

Black
w/Black Center
and Blue Sides

Black
w/Black Center
and Black Sides

Smoke
w/Black Center
and Gray Sides

Desert Tan
w/Black Center
and Brown Haze Sides

* Jeep TJ 97-02 & 03-06 Bench Slip Covers Shown.

RUBICON BENCH SEATS

PREMIUM SUSPENSION REAR BENCH

Tired of hearing "Are we there yet?!" coming from the backseat? Now the entire family can enjoy the comfort of MasterCraft's suspension technology with our exclusive Rubicon Bench. Constructed with the same comfort and durability that made MasterCraft suspension seats a mainstay in the recreational off-road market, the MasterCraft Rubicon Bench was developed to bolt right into popular Jeep models such as the CJ7, YJ and TJ series without special tools or drilling required. Looking to replace the uncomfortable OE rear bench in your 4-door Jeep JK? The 46-inch MasterCraft Rubicon will bolt right in with the purchase of our JK rear mounting kit (part no. 624407). If you prefer a bucket seating solution for more containment, the same rear mount kit will also adapt to accept two Baja RS, Sahara, Rubicon or Nomad seats. The Rubicon Bench seats two people comfortably and also features slots for the lap belts as well as anti-sub slots and shoulder harness loops if five point belts are utilized. The MasterCraft Rubicon Bench also works well in the Jeep CJ5s, early Broncos (1966-1977) as well as the Land Cruisers, Land Rovers and the International Scout with some drilling required. The MasterCraft Rubicon Bench varies in width from 36-inch to 46-inch depending on application.

MADE IN THE USA

JEEP JK '07-'15	BLACK w/RED	BLACK w/BLUE	ALL BLACK	SMOKE w/GRAY	TAN w/BROWN
STANDARD BRS STITCH	310101	310102	310003	310091	310104
DIRTSPORT STITCH PATTERN	310105	310106	310107	310108	310109
JEEP TJ '03-'06	BLACK w/RED	BLACK w/BLUE	ALL BLACK	SMOKE w/GRAY	TAN w/BROWN
STANDARD BRS STITCH	310110	310111	310032	310054	310112
DIRTSPORT STITCH PATTERN	310113	310114	310115	310116	310117
JEEP TJ '97-'02	BLACK w/RED	BLACK w/BLUE	ALL BLACK	SMOKE w/GRAY	TAN w/BROWN
STANDARD BRS STITCH	310118	310119	310061	310062	310120
DIRTSPORT STITCH PATTERN	310121	310122	310123	310124	310125
JEEP YJ '87-'95	BLACK w/RED	BLACK w/BLUE	ALL BLACK	SMOKE w/GRAY	TAN w/BROWN
STANDARD BRS STITCH	310126	310127	310069	310070	310128
DIRTSPORT STITCH PATTERN	310129	310130	310131	310132	310133
JEEP CJ '76-'86	BLACK w/RED	BLACK w/BLUE	ALL BLACK	SMOKE w/GRAY	TAN w/BROWN
STANDARD BRS STITCH	310134	310135	310077	310078	310136
DIRTSPORT STITCH PATTERN	310137	310138	310139	310140	310141
FORD BRONCO '66-'77	BLACK w/RED	BLACK w/BLUE	ALL BLACK	SMOKE w/GRAY	TAN w/BROWN
STANDARD BRS STITCH	310142	310143	310085	310086	310144
DIRTSPORT STITCH PATTERN	310145	310146	310147	310148	310149

BENCH CUSTOM ADD-ON OPTIONS		* See Page 28
ADD ELECTRONIC SEAT HEATER (Installed)	600006 (x2)	
ADD REAR SEAT POCKET	600008 (x2)	
ADD CAMELBAK POCKET	600060 (x2)	
ADD CAMELBAK SET (Packet, Reservoir & Tube included)	600061 (x2)	

* Please note, benches require two of each seat option.



BRS COVER: Black w/Black Center and Red Sides
BRS COVER: Black w/Black Center and Blue Sides
BRS COVER: Black w/Black Center and Black Sides
BRS COVER: Smoke w/Black Center and Gray Sides
BRS COVER: Desert Tan w/Black Center and Brown Haze Sides
DIRTSPORT: Black w/Red Center and Red Sides
DIRTSPORT: Black w/Blue Center and Blue Sides
DIRTSPORT: Black w/Black Center and Black Sides
DIRTSPORT: Smoke w/Gray Center and Gray Sides
DIRTSPORT: Desert Tan w/Brown Haze Center and Brown Haze Sides

* For Full Dimensions See Pg. 38

SEAT MOUNTING BRACKETS AND ADJUSTERS

FOR MOST POPULAR OFF-ROAD VEHICLES

Seamlessly install and adapt your MasterCraft seat to your vehicle using our line of heavy-duty and easy-to-install bracket and mounting kits. Looking for adjustability? MasterCraft also offers durable, easy-glide seat adjusters with a lever or towel bar release. All mounting bracket and adjuster hardware is fully tested ensuring FMVSS compliance for your seating system.

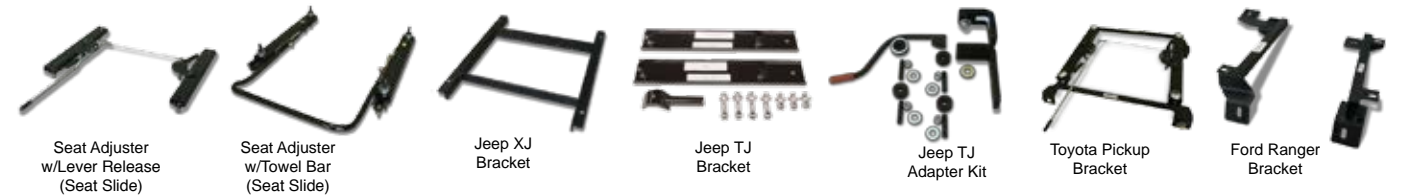

Seat Adjuster w/Lever Release (Seat Slide) | Seat Adjuster w/Towel Bar (Seat Slide) | Jeep XJ Bracket | Jeep TJ Bracket | Jeep TJ Adapter Kit | Toyota Pickup Bracket | Ford Ranger Bracket

VEHICLES REQUIRING MOUNTING BRACKETS

VEHICLES REQUIRING MOUNTING BRACKETS	SEAT SLIDES ONLY W/LEVER RELEASE	
	SEAT SLIDES ONLY, DEM STYLE W/TOWEL BAR	620030
	SEAT SLIDES ONLY, DEM STYLE W/TOWEL BAR	620031
FORD BRONCO 66-77, MOUNTING BRACKET, DRIVER (INCLUDES ADJUSTER W/TOWEL BAR)		620704
FORD BRONCO 66-77, MOUNTING BRACKET, PASSENGER (INCLUDES ADJUSTER W/TOWEL BAR)		620705
FORD RANGER EXTENDED CAB 83-92, MOUNTING BRACKET, DRIVER (Mount Only, Order Adjuster Separately)		621304
FORD RANGER EXTENDED CAB 83-92, MOUNTING BRACKET, PASSENGER (Mount Only, Order Adjuster Separately)		621305
FORD RANGER STANDARD CAB 93-02, MOUNTING BRACKET, DRIVER (Mount Only, Order Adjuster Separately)		621104
FORD RANGER STANDARD CAB 93-02, MOUNTING BRACKET, PASSENGER (Mount Only, Order Adjuster Separately)		621105
FORD RANGER EXTENDED CAB 93-02, MOUNTING BRACKET, DRIVER (Mount Only, Order Adjuster Separately)		621106
FORD RANGER EXTENDED CAB 93-02, MOUNTING BRACKET, PASSENGER (Mount Only, Order Adjuster Separately)		621107
FORD F-150 STANDARD CAB 92-96, MOUNTING BRACKET, DRIVER (Mount Only, Order Adjuster Separately)		622904
FORD F-150 STANDARD CAB 92-96, MOUNTING BRACKET, PASSENGER (Mount Only, Order Adjuster Separately)		622905
TOYOTA PICKUP 84-88, MOUNTING BRACKET, DRIVER OR PASSENGER (Mount Only, Order Adjuster Separately)		623204
TOYOTA PICKUP STANDARD CAB 89-95, MOUNTING BRACKET, DRIVER (Mount Only, Order Adjuster Separately)		623304
TOYOTA PICKUP STANDARD CAB 89-95, MOUNTING BRACKET, PASSENGER (Mount Only, Order Adjuster Separately)		623305
TOYOTA TACOMA STANDARD CAB 95-03, MOUNTING BRACKET, DRIVER (Mount Only, Order Adjuster Separately)		623404
TOYOTA TACOMA STANDARD CAB 95-03, MOUNTING BRACKET, PASSENGER (Mount Only, Order Adjuster Separately)		623405
JEEP TJ 97-02, ADAPTER KIT, DRIVER (Use O.E.M. Sliders)		624004
JEEP TJ 97-02, ADAPTER KIT, PASSENGER (Use O.E.M. Sliders)		624005
JEEP TJ (INC. UNLIMITED) 03-06, ADAPTER KIT, DRIVER (Use O.E.M. Sliders)		624204
JEEP TJ (INC. UNLIMITED) 03-06, ADAPTER KIT, PASSENGER (Use O.E.M. Sliders)		624205
JEEP JK 07-12, FRONT SEAT ADAPTER KIT, DRIVER (Use O.E.M. Sliders)		624405
JEEP JK 07-12, FRONT SEAT ADAPTER KIT, PASSENGER (Use O.E.M. Sliders)		624406
JEEP JK 07-12 (4 DOOR), REAR SEAT MOUNTING BRACKET - BENCH or BUCKET SEATS		624407
JEEP CHEROKEE (XJ) 84-96, ADAPTER KIT, DRIVER or PASSENGER (Use O.E.M. Sliders)		624500
JEEP CHEROKEE (XJ) 97-01, ADAPTER KIT, DRIVER or PASSENGER (Use O.E.M. Sliders)		624501
SUZUKI SAMURAI 86-94, ADAPTER KIT, DRIVER or PASSENGER		624502
POLARIS RZR XP650-900 08-15, MOUNTING BRACKET, DRIVER or PASSENGER (FOR SPORTSMAN SEAT)		624409

* Toyota Pickup 84-88 (623204) Please Specify Cab Type and Year.

VEHICLES THAT HAVE DIRECT BOLT-IN APPLICATIONS

VEHICLES THAT HAVE DIRECT BOLT-IN APPLICATIONS	FRONT SEAT	REAR SEAT
CHEVY BLAZER/K5 69-94 (*If Equipped w/Original Bucket Seats Only)	BAJA RS, RUBICON, SPORTSMAN (Use O.E.M. Sliders)	N/A
FORD BRONCO 66-77	N/A	FIT COVER or 40" RUBICON BENCH
JEEP CJ-5 76-83	BAJA RS, RUBICON (Use O.E.M. Sliders)	FIT COVER or 36" RUBICON BENCH
JEEP CJ-7 76-86	BAJA RS, RUBICON (Use O.E.M. Sliders)	FIT COVER or 36" RUBICON BENCH
JEEP WRANGLER YJ 87-95	BAJA RS, RUBICON (Use O.E.M. Sliders)	FIT COVER or 36" RUBICON BENCH
JEEP TJ 97-02	N/A	FIT COVER or 40" RUBICON BENCH
JEEP TJ (INCL UNLIMITED) 03-06	N/A	FIT COVER or 40" RUBICON BENCH
KAWASAKI TERYX 08-11	PWR SPORT	*SPECIAL
YAMAHA RHINO 04-11	PWR SPORT	40" ORIGINAL BENCH *SPECIAL
POLARIS RZR XP650-900 08-15, MOUNTING BRACKET, DRIVER or PASSENGER	COMPASS	COMPASS
POLARIS RZR X1000 13-15, MOUNTING BRACKET, DRIVER or PASSENGER	COMPASS (Use O.E.M. Sliders)	COMPASS

* Please note, Chevy Blazer K5 (65-94)

SEAT ADD-ON OPTIONS TO CUSTOMIZE OUR SEATS TO YOUR EXACT NEEDS

Whether it is commuting during the week or running errands on the weekend, we spend a lot of time in our vehicles. Match your seats to your lifestyle and add comfort and convenience with custom options such as seat heaters, lumbar support and seat pockets! **Add-on Seat Options are not available on Nomad or Sahara seats.**



ADJUSTABLE LUMBAR SUPPORT

This patented lumbar support system adjusts up to 3-inches in the lower lumbar area for improved support and even pressure distribution. The advanced design of the Schukra® system allows the unit to hold its form, even during the most rigorous trail or racing adventures. The Schukra Lumbar System can be installed into any MasterCraft seat at the time of assembly and is available with a left or right side adjustment handle.



ELECTRONIC SEAT HEATER

Ideal for cold weather or used year-round to relieve tension or stress in the lower back, Seat Heaters are pre-installed during the seat's assembly so be sure to include this option when ordering your new MasterCraft seat. The Seat Heaters are 12-volt, made in the U.S.A units and meet all FMVSS 302 flammability requirements. The included electrical harness is complete with switch and features an indexed GXL 18 wire to simplify installation. Available on any MasterCraft® seats or benches. Note: these Seat Heaters are not compatible with the factory JK seat heater switches.



ADJUSTABLE HEADREST

Three-position Adjustable Headrest is integrated into the steel seat frame and is available as an option only on the MasterCraft Baja RS®. This upgrade cannot be installed after the seat is made, so be sure to order when you order your seat. **Only available on the BAJA RS and RUBICON BENCHES for 4-door JKs.**

REAR SEAT POCKET

Add a durable and roomy pocket to the back of your MasterCraft seat to conveniently store all your essentials and keep your items safely contained during spirited trail rides or while conquering the Baja desert. The Rear Seat Pocket measures about 8-inch x 11-inch and features a ruggedized molded plastic No. 10 zipper closure for maximum durability and strength. The Rear Seat Pocket is available as an option at the time of order on any MasterCraft® Safety seat.



CAMELBAK™ POCKET or POCKET w/SET

Looking for a hydration solution for your racecar or trail vehicle? Designed to fit Camelbak's Omega 3 Water Beast reservoir, MasterCraft can add a Camelbak™ pouch to your seat back ensuring you have the needed hydration for any situation. The Omega 3 Water Beast offers a Big Bite valve with rugged construction and Hydro-Guard anti-microbial technology ensuring delivery of safe and clean water during extreme operational conditions.



CUSTOM ADD-ON OPTIONS		
ADD ADJUSTABLE LUMBAR SUPPORT - HANDLE LEFT	600001	
ADD ADJUSTABLE LUMBAR SUPPORT - HANDLE RIGHT	600002	
ADD ELECTRONIC SEAT HEATER (Installed)	600006	
ADD REAR SEAT POCKET	600008	
ADD CAMELBAK POCKET	600060	
ADD CAMELBAK SET (Pocket, Reservoir & Tube included)	600061	

SEAT SAVER PROTECT YOUR SEATS

New and improved! Not only does the MasterCraft Seat Saver protect your MasterCraft seats from the weather and elements, it now also allows you to sit in the seat with the Seat Saver on (an important feature if you've had a rough day on the trail and are covered in muck)! Constructed from heavy-duty moisture-repellant Cordura® with easy-to-use hook-and-loop latches on the front and sides, this durable seat accessory is a must-have item to keep your MasterCraft seats protected from the environment and occasional mishaps. To use the seat with the Seat Saver on, simply pull up the hook-and-loop latches and the flap pushes in so you can sit in the seat without the need to remove the Seat Saver. Available in black and in sizes to fit most MasterCraft® Safety seats.

SEAT SAVER WITHOUT HEADREST	640154	
SEAT SAVER FOR 3G & 3G-4	640155	
SEAT SAVER FOR FIXED HEADRESTS	640158	
SEAT SAVER FOR RUBICON BENCH WITHOUT HEADRESTS	640161	
SEAT SAVER FOR ADJUSTABLE HEADRESTS	640164	

* Please Specify if You Have a 1" Wider or 2" Wider Seat When Ordering.



SEAT BOOSTER PADS

Our seat booster pad is offered in a 2-inch thickness with your choice of a bottom cushion, back cushion, or a bottom cushion attached to a back cushion as a combo. Available in Black Only.

SEAT BOTTOM PAD ONLY 2-Inch Thick	600026	
SEAT BACK PAD ONLY 2-Inch Thick	600027	
SEAT BACK & BOTTOM PAD COMBO 2-Inch Thick	600028	



PSS KITS PERSONAL SANITATION KITS

Gain much needed "relief" during long stretches in the racecar with MasterCraft's "Personal Sanitation System" (PSS Kit). This condom style catheter with drainage tube features heavy-duty vinyl construction and double-sided tape ensuring the kit stays in place and you stay clean and dry, even during the most rigorous racing.

	680100	
--	--------	--



CAMELBAK™ ACCESSORIES

Using a Camelbak™ Set (see previous page) with your MasterCraft seat? Get your accessories, supplies and other needs from us as well.

CAMELBAK RESERVOIR (INCL TUBE)	600062	
CAMELBAK CLEANING KIT	600063	
CAMELBAK TUBE DIRECTOR	600064	
CAMELBAK CLEANING TABLETS	600065	





MEL WADE, OWNER OF OFF-ROAD EVOLUTION, PILOTING HIS JEEP JK AT THE KING OF THE HAMMERS.



UTVs LINED UP FOR THE WALKER EVANS DESERT CHAMPIONSHIP IN LAUGHLIN, NV.

ROBBY GORDON AND CO-PILOT KELLON WALCH GETTING READY TO TACKLE ANOTHER RACE IN BAJA.



RUSTY'S OFF-ROAD JEEP XJ WITH RUBICON SEATS.



REMO SAGASTUME'S 1992 BRONCO BUILD WITH SPORTSMAN SEATS.



RUSTY'S OFF-ROAD 2006 JEEP TJ WITH RUBICON SEATS WITH DIRT SPORT COVERS.



TRAXXAS CEO MIKE JENKINS' TORC SERIES PRO 4 TRUCK.



GRAB HANDLES

Do your passengers need something to hold onto while conquering the Rubicon Trail or Moab? These easy-to-install grab handles adapt to your Jeep or off-road vehicle in just a matter of minutes with the hook and loop system and offer the often-needed "Oh No!" handle. Manufactured from 1.5-inch nylon webbing for strength and durability, the 5-inch Thermo-Press handle is ergonomically shaped and does not collapse in your hand. MasterCraft also added a third mounting strap for added support when you really need it. Available in Black for 2-inch or 3-inch diameter tubing.

*Not recommended for support during ingress and egress of the vehicle.



STANDARD 2" BLACK - SINGLE	683104	
STANDARD 2" BLACK - PAIR	683204	
STANDARD 3" BLACK - SINGLE	683404	
STANDARD 3" BLACK - PAIR	683304	
2" UTV BLACK (2-HANDLE) - SINGLE	684104	
2" UTV BLACK (2-HANDLE) - PAIR	684204	
JK BLACK - REAR (SET OF 2)	684205	
JK BLACK - FRONT AND REAR (SET OF 4)	684206	



VINYL TOOL TOTES

Available in three standard sizes, these water repellant totes feature interior padding on the bottom to protect your tools. The diagonal zipper allows the bag to open wide, providing easy access inside - even with gloves on. To hold the bag in place, we have included bag straps that screw or pop rivet to the floor and wrap around the bag with buckle closure for keeping your tools safely and securely stowed during transport or during the most spirited off-road adventures.

SMALL - RED (12" x 6" x 2 1/2" w/1 Bag Strap)	640101	
SMALL - BLACK (12" x 6" x 2 1/2" w/1 Bag Strap)	640103	
REGULAR - RED (17" x 6" x 2 1/2" w/2 Bag Straps)	640105	
REGULAR - BLACK (17" x 6" x 2 1/2" w/2 Bag Straps)	640107	
LARGE - RED (17" x 8" x 3 1/2" w/2 Bag Straps)	640109	
LARGE - BLACK (17" x 8" x 3 1/2" w/2 Bag Straps)	640111	

VINYL DOOR BAGS

Created for first-aid supplies, the vinylized bag features a hook-and-loop closure allowing fast and easy access in emergencies. Attaches to nearly any door or panel and will also hold towels, goggles, tools, batteries or anything else!

Available in red or black.

RED (8" x 8")	640121	
BLACK (8" x 8")	640123	

VINYL JIMCO BAGS

As the namesake states, these triangular shaped bags were first used by the winningest off-road chassis builder in SCORE's history. Designed to fit perfectly in the odd shapes between the roll cage tubes, the Jimco bags work great to store extra gloves, maps, and other racing essentials. Attached with durable hook-and-loop closure. Available in red and black.

SMALL - RED	640113	
SMALL - BLACK	640115	
LARGE - RED	640117	
LARGE - BLACK	640119	



PADDED WALKER GEAR BAGS

This handy bag was created especially for Walker Evans. Our 10-inch x 20-inch bag with zipper closure is made of tough, waterproof and tear-resistant material, padded for durability and includes two carry handles.

RED (10" x 20")	640126	
BLACK (10" x 20")	640128	



IMPACT GUN HOLSTER

Choose from two sizes to accommodate 12-volt to 36-volt Impact Guns. Super rugged vinylized material keeps the impact gun from moving about, and buckle closure secures the gun. Other pockets hold lug nuts, socket and spare battery. Attaches with hook and loop panel and straps. Available in Black only.

SMALL - TYPICALLY HOLDS UP TO 18v (16" x 12" L-Shape)	640130	
LARGE - TYPICALLY HOLDS UP TO 24v (20" x 16" L-Shape)	640131	



CANVAS TOOL BAG

The MCS Canvas Tool Bag is made from a heavy-duty cotton-duck canvas material and is equipped with two convenient carrying handles and a bag strap for mounting to a door bar or chassis of an off-road truck if desired. Great for storing tools, jumper cables, tow-ropes, and wrench roll-ups, this durable tool bag features a reinforced construction ensuring years of use.

BLACK (17" x 8" x 6" w/1 Bag Strap)	640142	
-------------------------------------	--------	--



CANVAS TOOL ROLL-UPS

Wrench Roll-Ups Constructed from 100% cotton-duck canvas, these organizers fit open-end box wrenches and close with a hook-and-loop strap.

SMALL ROLL-UP - RED (27" w x 26" t w/16 Slots - 13" Folded)	640174	
SMALL ROLL-UP - BLACK (27" w x 26" t w/16 Slots - 13" Folded)	640139	
2 POCKET ROLL-UP - RED (28 3/4" w x 29" t w/8 Slots - 14" Folded)	640176	
2 POCKET ROLL-UP - BLACK (28 3/4" w x 29" t w/8 Slots - 14" Folded)	640140	
4 POCKET ROLL-UP - RED (28 3/4" w x 29" t w/4 Slots - 14" Folded)	640178	
4 POCKET ROLL-UP - BLACK (28 3/4" w x 29" t w/4 Slots - 14" Folded)	640141	



CLAMSHELL HELMET BAG

The soft padding inside protects your valuable helmet from scratches, dings, and dents. Outside you will find a durable Cordura® outer shell with full zipper closure and molded rubber handle. Available in Black only.

BLACK	640148	
-------	--------	--



DIRT GEAR BAG

The Canvas Dirt Gear Bag features a helmet storage pocket and 5 outer pouches that vary in size. The bag also features durable handles and a detachable shoulder strap.. Available in Black only.

BLACK 13"h x 32"w x 13"d	640150	
--------------------------	--------	--



SAT PHONE BAG

Handy bag constructed from heavy-duty cordura features rugged zipper closure and padded interior to safely hold a standard satellite telephone. Also fits half liter bottles like water or other sport drinks. Includes a hook-and-loop strap attachment.

BLACK	640132	
-------	--------	--

1" x 6' (or 15') STRAP w/Vinyl Coated S-Hooks

1" x 6' nylon strap with cam buckles and large vinyl coated S-hooks. Rated at 1200 pounds maximum load. Available in Red only.

RED - 6' LENGTH	400001	
RED - 15' LENGTH	400003	



1" x 6' RATCHET STRAP

1" x 6' nylon strap with wide handle ratchet (for folks with big hands) with either large vinyl coated S-hooks OR Snap Hooks. Rated at 2800 pounds maximum load. Available in Red only.

RED w/ VINYL COATED S-HOOKS	400004	
RED w/ SNAP HOOKS	400006	



1" x 15' RATCHET STRAP

1" x 15' nylon strap with wide handle ratchet (for folks with big hands) with either large vinyl coated S-hooks OR Snap Hooks. Rated at 2800 pounds maximum load. Available in Red only.

RED w/ VINYL COATED S-HOOKS	400007	
RED w/ SNAP HOOKS	400008	



2" x 7' RATCHET STRAP w/Chain Extension or Twisted Snap Hooks

2" x 7' heavy-duty strap features wide handle ratchet and Anchor hooks on chains OR large twisted snap hooks. Rated at 10,000 pounds maximum load. Available in Red or Yellow.

RED w/ CHAIN EXTENSION	400011	
YELLOW w/ CHAIN EXTENSION	400012	
RED w/ TWISTED SNAP HOOKS	400013	
YELLOW w/ TWISTED SNAP HOOKS	400014	



2" x 8' RATCHET STRAP w/Twisted Snap Hooks & Axle Loop

2" x 8' heavy-duty strap features wide handle ratchet, Snap hook at one end and Axle loop with protective sleeve at the other. 12" of adjustment. Rated at 10,000 pounds maximum load.

RED	400015	
YELLOW	400016	





1.75-inch x 1.75-inch - 5-POINT RESTRAINTS

5-Point Latch and Link System with Integrated Latch Guard. 1.75-inch x 55-inch Pull Down Lap Belt and 1.75-inch x 48-inch Dual Shoulder Harness. Available in SFI 16.1 with Bolt-In, Snap-In or Wrap-Around ends. Anti-submarine belt included, Available in Black Only.

SFI COMPLIANT
SPEC 16.1

BOLT-IN MOUNTING	113004
SNAP-IN MOUNTING	113204

3-inch x 3-inch - 5-POINT RESTRAINTS

5-Point Latch and Link System with Integrated Latch Guard. Features 3-inch x 55-inch Pull Down Lap Belts and 3-inch x 48-inch Dual Shoulder Harness. Available in SFI 16.1 or SFI 16.5 with Bolt-In, Snap-In or Wrap-Around ends. Anti-submarine belt included, Available in Black Only.

SFI COMPLIANT
SPEC 16.1

BOLT-IN MOUNTING	110004
SNAP-IN MOUNTING	110204

3-inch x 3-inch - 5-POINT RESTRAINTS w/QSRs

5-Point Latch and Link System with Integrated Latch Guard. Features 3-inch x 55-inch Pull Down Lap Belts and 3-inch x 48-inch Dual Shoulder Harnesses with our exclusive QSRs for ease of adjustment, especially during speedy driver changes. Available in SFI 16.1 or SFI 16.5 with Bolt-In, Snap-In or Wrap-Around ends. Anti-submarine belt included, Available in Black Only.

SFI COMPLIANT
SPEC 16.1

BOLT-IN MOUNTING	111134
SNAP-IN MOUNTING	111234



QSR - QUICK SAFETY RELEASE

Offering ease of adjustment, the QSR hardware adjusts by simply flipping up the lever and pulling down on the shoulder harness end. QSR hardware is not available on the lap belts.

RATCHET ADJUSTER

Available as an option on any of the MasterCraft three-inch 16.1 SFI rated lap belts, MasterCraft's Ratchet adjuster is manufactured from a heat-treated chromoly steel and features a double locking mechanism for added safety. The ratcheting mechanism can be specified for either left or right side use and features a bolt-in installation on the mechanism side while the opposing side features the standard three-bar wrap or bolt-in option (available with clip-in installation as well). The ratcheting mechanism can replace one of the standard lap adjusters (left or right, depending on your preference) allowing the belt to be quickly and easily tightened without the need for outside crew assistance. MasterCraft's ratchet style adjuster is only available with the purchase of a complete set of restraints. The ratcheting system will not be sold individually or with the purchase of a lap belt only. The mechanism uses a 1/4-inch drive ratchet (not included).



CUSTOM ADD-ON OPTIONS	
SEWN-IN HARNESS PADS	630014
3-TO-2 TRANSITION ON SHOULDER BELTS	132507
FOLD OVER AND SEWN ON SHOULDER BELTS	132508
QSR ADJUSTER UPGRADE (SHOULDER BELTS ONLY)	132503
RATCHET UPGRADE - LEFT SIDE	132505
RATCHET UPGRADE - RIGHT SIDE	132506

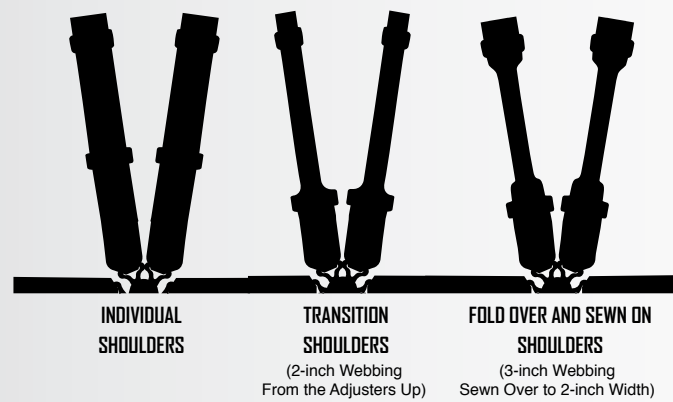

RESTRAINT HARDWARE	
SNAP-END MOUNTING HARDWARE (IPC)	600101
EYE-BOLT, NUT AND WASHER (1 SET)	600102
BOLT-IN MOUNTING HARDWARE (IPC)	600103
3-INCH 3-BAR (IPC)	600105



HARNESS PADS

MasterCraft harness pads are constructed from flame retardant materials and offer improved shoulder belt comfort for both two-inch and three-inch belts. The harness pads can be sewn into the shoulder belts or are available as a hook-and-loop wrap attachment that can be easily added and adjusted as needed to any existing shoulder harness. Available in Black Only.

SEWN-IN HARNESS PADS	
2-inch HOOK-AND-LOOP HARNESS PADS (Fits 1.75 and 2-inch Belts)	630036
3-inch HOOK-AND-LOOP HARNESS PADS	630025

* Sewn-In Harness Pads on custom restraint orders only. Sewn in Harness pads are not recommended with use of Frontal Head Restraints.



DRIVER WINDOW NETS

The MCS Driver's Net is designed for use in off-road chassis' and is a mandated safety item in several classes in the Lucas Oil Off Road Racing Series. The MCS net is constructed from three individual straps of 1-inch webbing for maximum coverage and improved lateral support. Available as a left or right side installation, each driver's net is adjustable for the ideal fit to your chassis. Features three bar for chassis tube attachments, ratchet strap for adjustability, and quick release connector closure.

SFI COMPLIANT
SPEC 27.1

DRIVER'S NET - LEFT SIDE	652001
DRIVER'S NET - RIGHT SIDE	652002

WINDOW NETS

Available in our standard 1-inch ribbon style or in our exclusive mesh with 1-inch polyester binding, MasterCraft can custom handcraft window nets from a supplied pattern and to your exacting standards. Simply send us your pattern cut from cardboard or heavy paper (we can also accept most CAD files as well) and note the top, bottom, front and rear of the chassis in addition to the method of attachment.

SFI COMPLIANT
SPEC 27.1

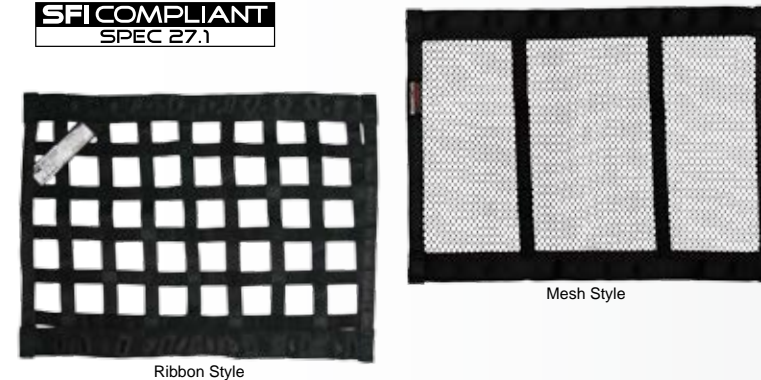

CLEVIS PIN

MasterCraft's adjustable clevis is domestically manufactured from 4130 chromoly and plated to resist corrosion. The bushings for the retaining bolt (not included) are made of stainless steel.

600100

LIMIT STRAPS

Any length, custom made-to-order. MasterCraft's limit straps are made from 7000-lb, Mil-Spec rated webbing material - strongest in the business! Simply measure your required eye-to-eye distance and provide us with the dimensions. Double (2-layer), Triple (3-layer), Quad (4-layer). Available in lengths starting at 8-inches in Black only.

STARTING AT

3G™

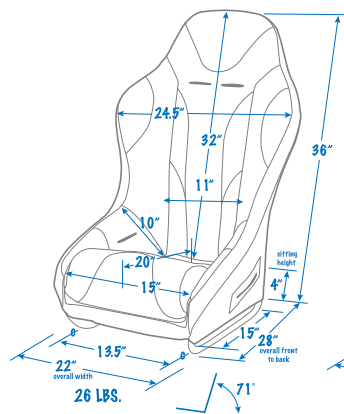

BAJA RS®

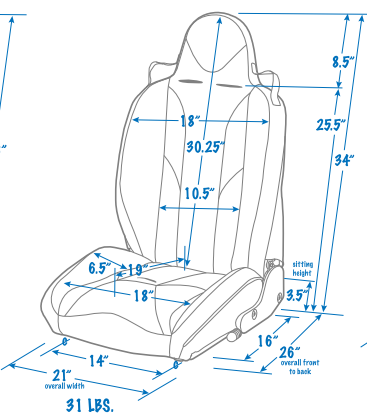

COMPASS™

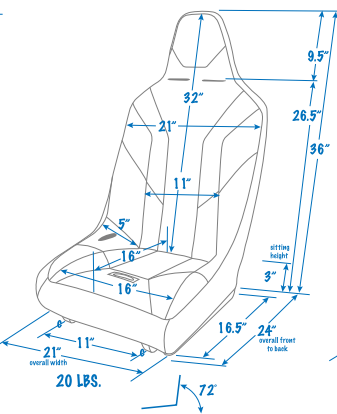

NOMAD™

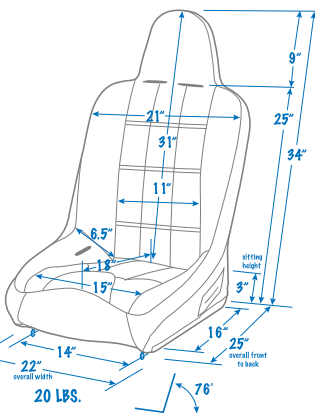

ORIGINAL™



PRO 4™

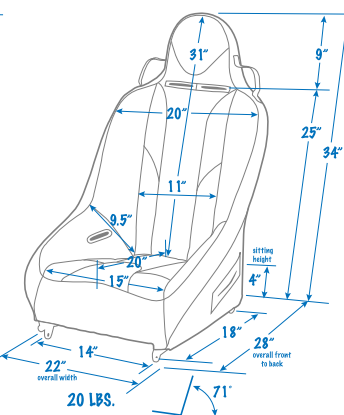

PROSEAT™

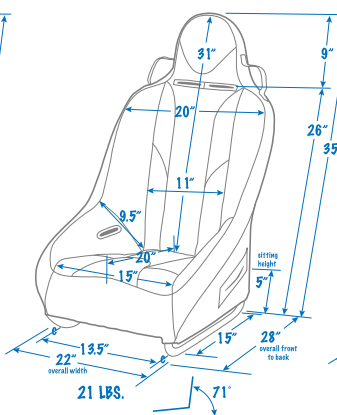

RUBICON™

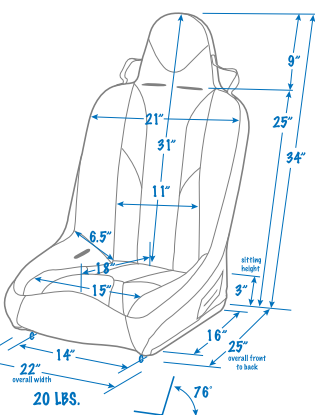

SAHARA™

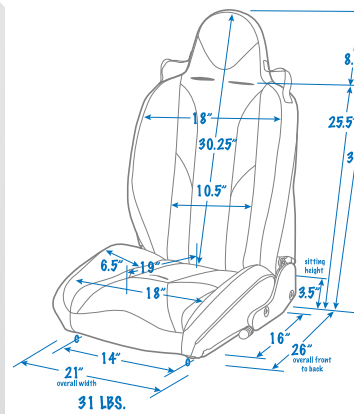

SPORTSMAN™

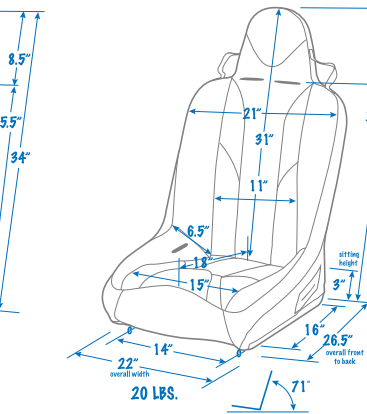

HS-1™

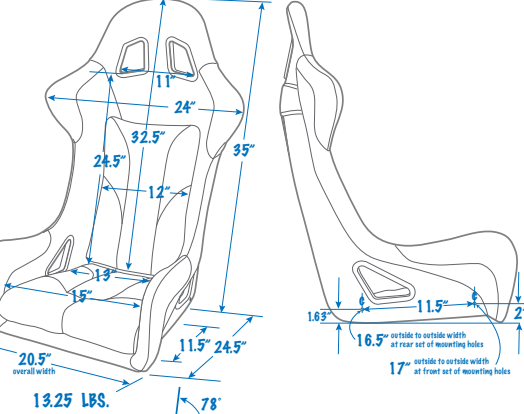

PWR SPORT™

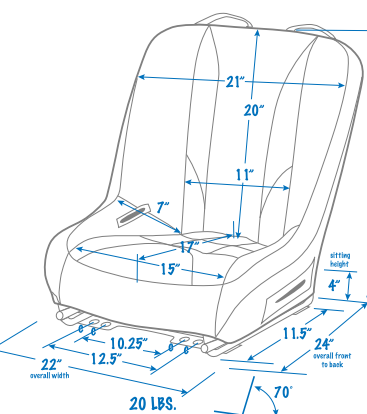

ORIGINAL BENCH

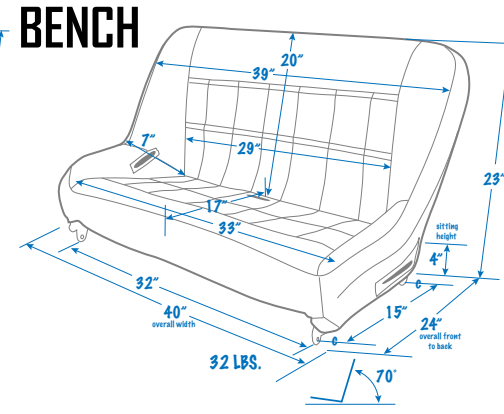

RUBICON BENCH

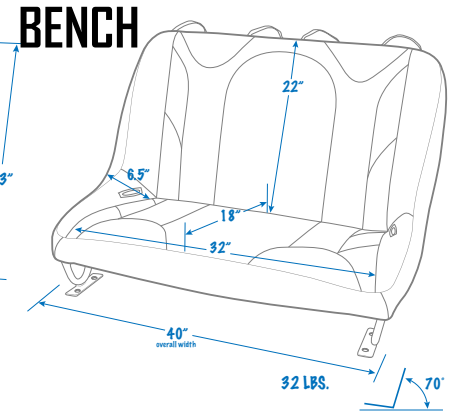

* OEM Replacement Seat Shown

* 40" Bench Shown. Available 36-inch to 46-inch lengths; depending on application.



ROBBY GORDON AND HIS CUSTOM-BUILT GORDINI TAKING ON THE BRUTAL DAKAR RALLY.