

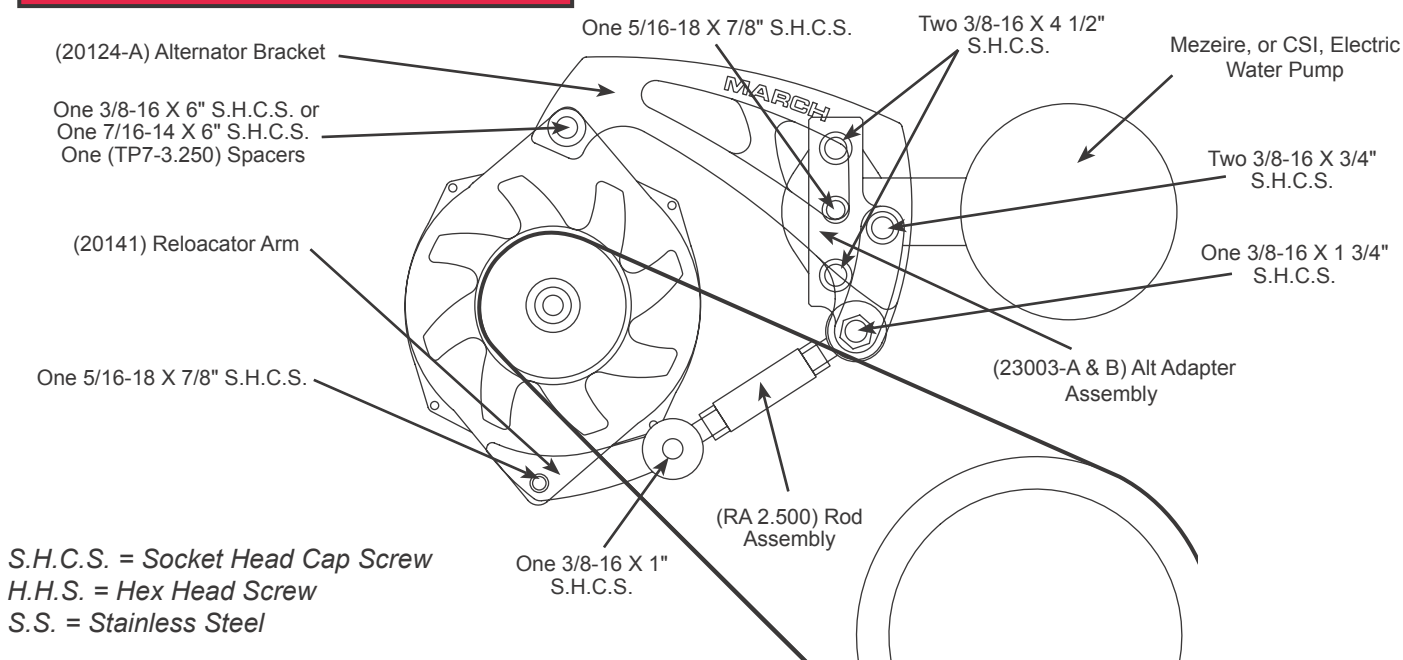

#23003, #23005, 23006, 23007

Chevy Big Block Electric Water Pump Alternator



Parts List

- 1- (20127-A) Alt Bracket
- 1- (23003) Adapter Assembly (between alt bracket & water-pump)
 - 1- (23003-A) adapter bracket body
 - 1- (23003-B) adapter bracket attachment
 - 1- (S144) 5/16-18 x 7/8" SHCS
- 2- (S276) 3/8-16 x 4 1/2" SHCS (adapter assembly & water-pump to engine block)
- 1- (S244) 3/8-16 x 3/4" SHCS (alt bracket to adapter assembly)
- 1- (S321) 3/8-16 x 1 3/4" HHS (alt bracket, SS Rod end to adapter assembly)
- 1- (TP7 3.250) Spacer (between alternator & alt bracket)
- 1- (S282) 3/8-16 x 6" SHCS (alt bracket, alternator to head)
- 1- (S376) 7/16-14 x 6" SHCS (alt bracket, alternator to head-alternate)
- 2- (S667) 3/8 x 5/8" Zinc Washers (between head & TP3 3.250 spacer- optional)
- 2- (S672) 7/16 x 1" Zinc Washers (between head & TP3 3.250 spacer- alternate)
- 1- (20141) Relocator
- 1- (RA 2.500) SS Rod
- 1- (S248) 3/8-16 x 1" SHCS (SS Rod end to relocator)
- 1- (S144) 5/16-18 x 7/8" SHCS (relocator to alternator)

Assembly Instructions

1. Bolt (23003) Adapter Bracket Assembly & Water pump to engine block using two (S276) 3/8-16 x 4 1/2" SHCS.
2. Bolt (20127-A) Alternator Bracket to (23003) Adapter Bracket Assembly using one (S244) 3/8-16 x 3/4" SHCS (upper hole) & one (S321) 3/8-16 x 1 3/4" HHS placing (RA-2.500) Stainless Steel Rod Assembly end between (20127-A) Alternator Bracket & (23003) Adapter Bracket Assembly (lower hole). Do not tighten completely yet.
3. Bolt Alternator to engine head using one (S282) 3/8-16 x 6" SHCS with 3/8x5/8 washer between bolt head and bracket (some engine heads use (S376) 7/16-14 x 6" SHCS) thru (20127-A) Alternator Bracket & one (TP3-3.250) Spacer between Alternator & engine head. (Note; if using a polished alternator, check the width of the ear on the alternator. If it is less than 2" wide, (S667) or (S672) washers may need to be used between alternator & spacer.) Completely tighten all screws.
4. Bolt (20141) Relocator to Alternator using one (S144) 5/16-18 x 7/8" SHCS.
5. Install belt. (if using power steering, install power steering belt first).
6. Bolt other end of (RA-2.500) Stainless Steel Rod Assembly to (20141) Relocator using one (S248) 3/8-16 x 1" SHCS.
7. Adjust belt tension using (RA-2.500) Stainless Steel Rod Assembly.

#23004, #23005, 23006, 23007

Chevy Big Block Electric Water Pump Power Steering

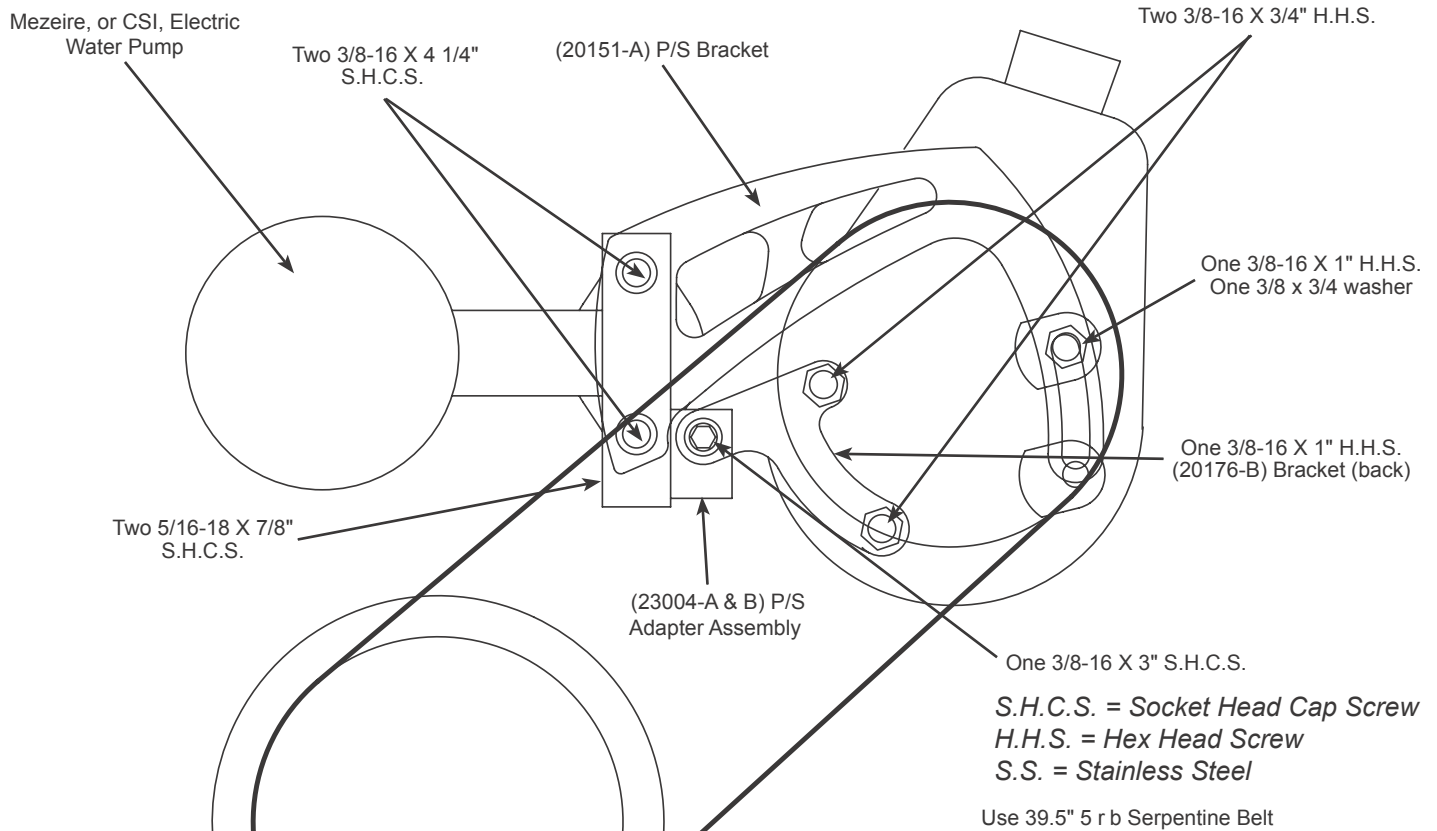

Parts List

- 1-(20151-A) Power Steering Bracket
- 1-(20176-A) Front Support Bracket
- 1-(20176-B) Rear Support Bracket
- 2-(S144) 5/16-18 x 7/8" SHCS (assembly)
- 2-(S275) 3/8-16 x 4 1/4" SHCS
- 1-(S266) 3/8-16 x 3" SHCS
- 2-(S311) 3/8-16 x 3/4" HHS
- 2-(S312) 3/8-16 x 1" HHS
- 4-(S666) washers

Assembly Instructions

1. Mount the (20151-A) Power Steering Bracket, (23004) Adapter Bracket Assembly & Water pump to engine block using two (S275) 3/8-16 x 4 1/4" SHCS.
2. If your power steering pump came equipped with a mounting stud at the rear of the pump, use an 11/16" wrench to remove the mounting stud from the pump unit (fig. 1).

3. Mount the (20176-A) Front Support Bracket to the power steering pump using two (S311) 3/8-16 x 3/4" HHS.
4. Mount the (20176-B) Rear Support Bracket to the power steering pump using one (S312) 3/8-16 x 1" HHS. Do not tighten at this time.
5. Mount (20176-A & B) Support Brackets to (23004) Adapter Bracket Assembly using one (S266) 3/8-16 x 3" SHCS. Leave loose for adjustment. Now tighten the (20176-B) Rear Support Bracket to the power steering pump.
6. Mount (20151-A) Power Steering Bracket to power steering pump using one (S312) 3/8-16 x 1" HHS & one (S666) spacer washer. Leave loose for adjustment.
7. Mount power steering pulley to power steering pump shaft. Install belt and adjust belt tension by pulling up on the power steering pump. Belt tension is correct when there is no more than 1/4" play in the belt at mid-point between the power steering pulley & the crank pulley. Lock the belt tension by tightening the adjustment bolt with a 9/16" opened end wrench (fig. 10).
8. Tighten (S266) 3/8-16 x 3" SHCS (step 5) & (S312) 3/8-16 x 1" HHS (step 6).