



Installation Instructions
For Part Numbers:

997-326-LPP

2015 Ford Mustang
2.3L EcoBoost 4cyl

Component Identification

1	Windstorn Premium Filter	1
2	Intake Tube	1
3	Cold Air Box	1
4	Filter Adapter	1
5	Air Box Lid	1
6	Window	1
7	Reducing Coupler	1
8	Hump Hose	1
9	Hardware and Instructions	1
10	#40 Hose Clamp	1
11	#56 Hose Clamp	1
12	#68 Hose Clamp	2
13	Aluminum Fitting	1
14	1/4" Flat Washer	9
15	1/4"-20 Button Head Screw	9
16	#8 Flat Washer	1
17	Button Head Screw	1
18	Grommet	1
	O Ring	1

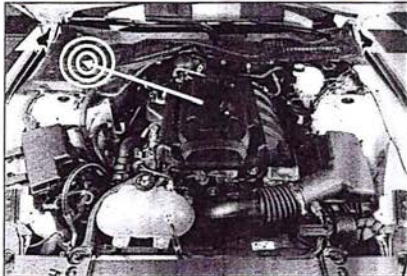
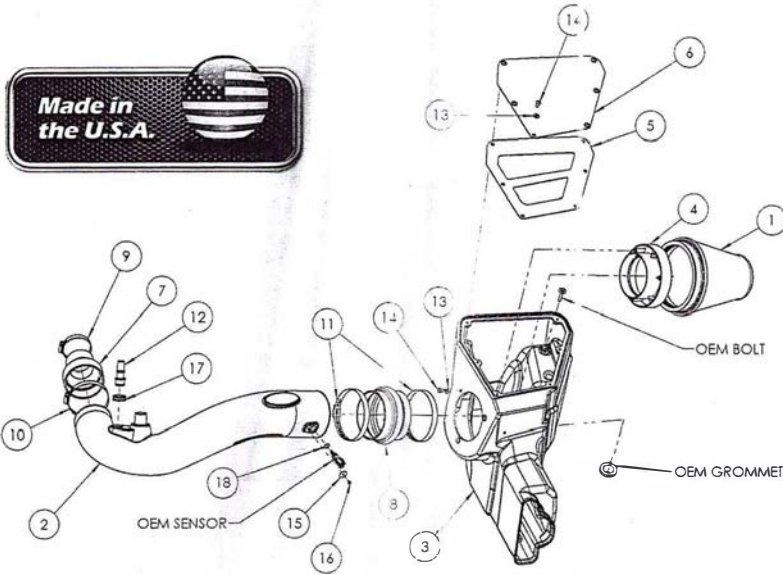

1. Remove the battery box cover in the cowl and disconnect the negative battery terminal.

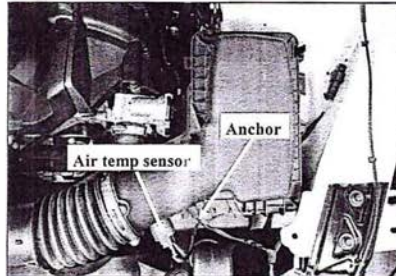

2. Loosen the clamp on the intake tube and slide it off of the airbox. Gently pry the harness anchor out of the airbox and disconnect the air temp sensor.

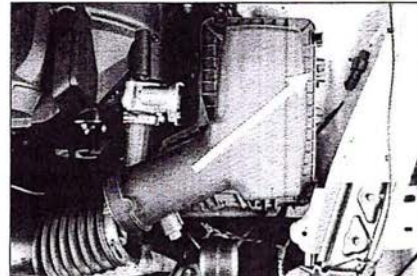

3. Remove the 6mm airbox mounting bolt in the inner fender and lift the entire airbox assembly out of the vehicle. Set the bolt aside for now. It is to be reused.

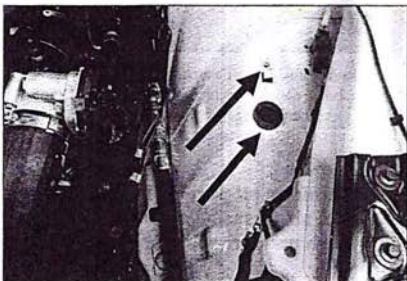

4. Be sure the speed clip and the airbox grommet remain inside the vehicle. They will be reused.

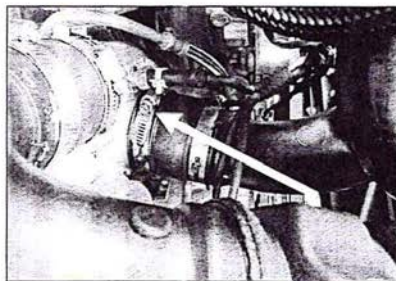

5. Loosen the clamp on the turbo inlet coupler.

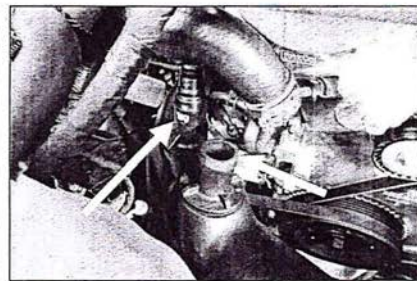

6. Disconnect the PCV and turbo bypass lines from the intake tube and remove the tube from the vehicle.

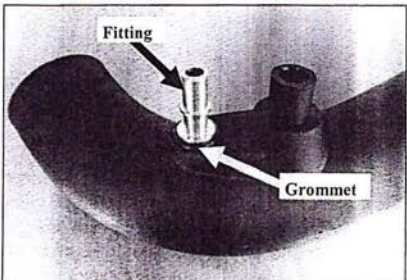

7. Insert the Grommet and Aluminum Fitting into the Airaid Intake tube as shown.

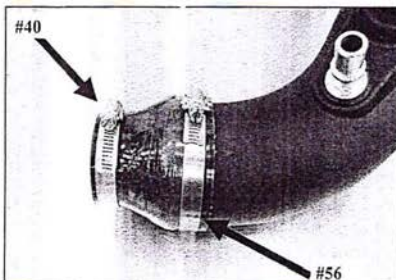

9. Slide the Reducer and Clamps onto the turbo side of the Intake Tube as shown. Leave the clamps loose for now.

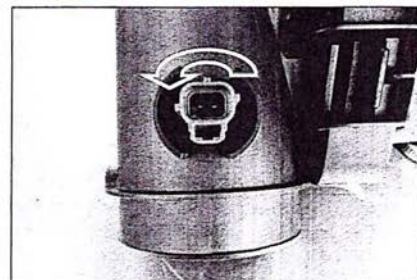

8. Tilt the air temp sensor rearward so the locking tab clears the ramp and rotate it counterclockwise 1/4 turn to release it.

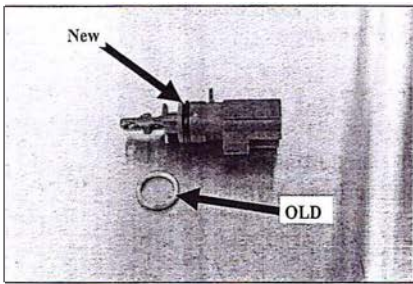

10. Replace the OEM O ring on the sensor with the supplied Airaid O ring.

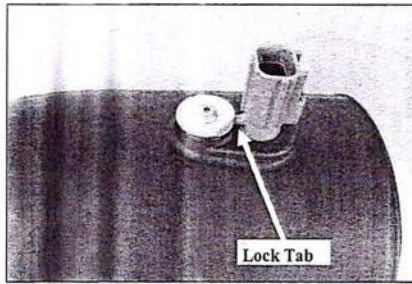

11. Insert the air temperature sensor into the Airaid intake tube as shown and secure it using the #8 Screw and Washer.

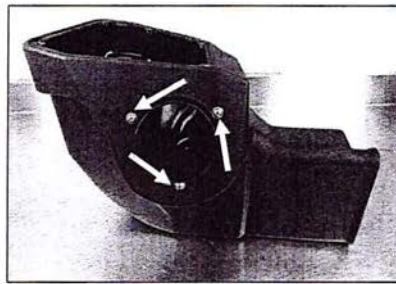

12. Install the Filter Adapter onto the Cold Air Box as shown using the three 1/4-20 Button Head Screws and 1/4" Flat Washers.

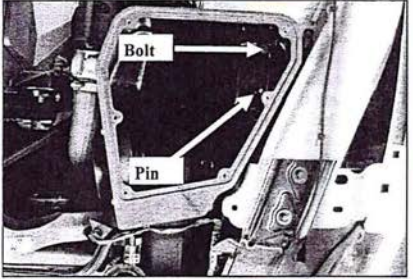

13. Place the Airaid Airbox assembly into the engine compartment as shown with the locator pin on the bottom of the box inside the fender grommet. Secure the airbox by reusing the 6mm bolt removed in step #3.

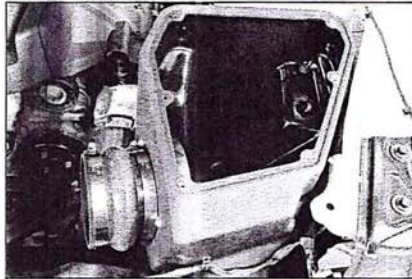

14. Slide the Hump Hose and Clamps onto the Filter Adapter as shown. Do not tighten the clamps at this time.

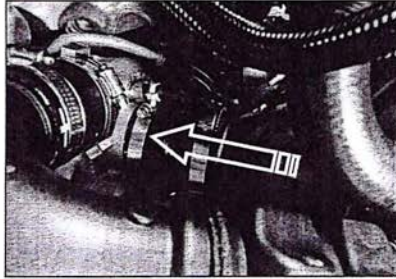

15. Lower the Intake tube down into position and slide the reducer onto the turbo inlet.

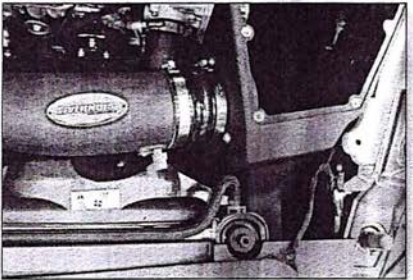

16. Insert the large end of the Intake Tube into the Hump Hose and tighten all 4 Intake Clamps at this time.

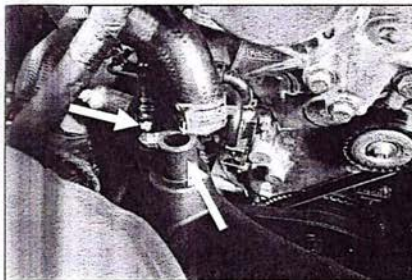

17. Reconnect the PCV and bypass line to the Airaid Intake Tube.

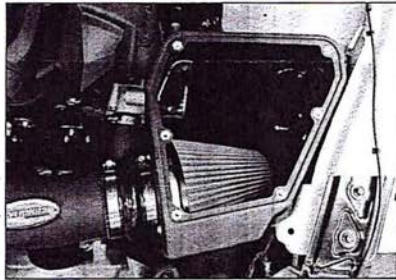

18. Install the Windstorm Premium Filter onto the Filter Adapter inside of the Airbox.

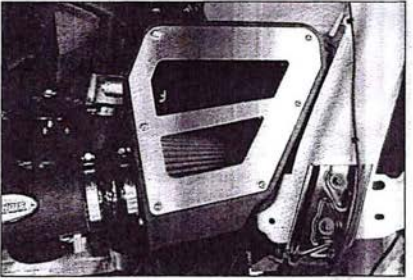

19. Remove the protective film from the Lid and Window before installation. Install the Airbox lid and Window onto the Airbox, with the Window on top, using 6

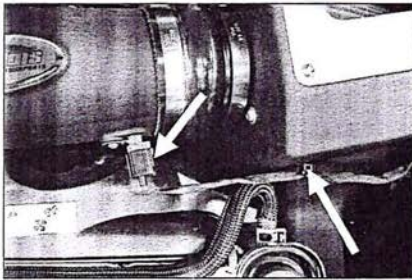

20. Reconnect the air temp sensor and plug the wire harness anchor into the Airbox.

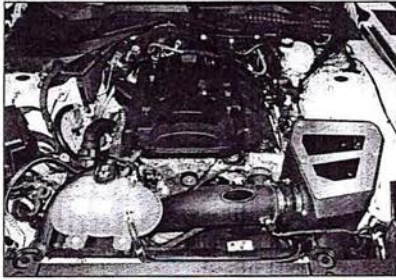

21. Double check your work. Make sure all clamps, hoses, bolts, and screws are tight. Double check the hood clearance. Reconnect the negative battery cable and reinstall the cover.