



Installation Instructions

For Part Number

997-270-LPP

2009-13 Chevrolet Silverado 1500/Tahoe/Suburban 1500/Avalanche
 GMC Sierra 1500/Yukon/Yukon XL 1500/Denali/Denali XL/
 2009-14 Cadillac Escalade/ESV/EXT
 4.8L V8, 5.3L V8, 6.0L V8*, 6.2L V8
 With Electric Cooling Fans Only
 *Does Not Fit 6.0L Engines after 2010

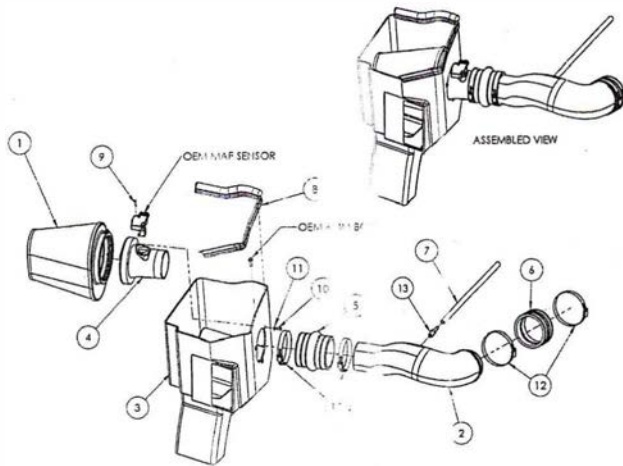

Component Identification

1.	Windstorm Premium Filter	1
2.	Intake Tube	1
3.	Cold Air Box	1
4.	Filter Adapter	1
5.	Urethane Hump Hose	1
6.	Urethane Coupler	1
7.	3/8" x 14" Breather Hose	1
8.	Weather Strip 25"	1
9.	8-32 x 1/2" Button Head Screw	2
10.	1/4-20 x 1/2" Button Head Screw	3
11.	1/4" Flat Washer	3
12.	#64 Hose Clamp	4
13.	1/4 NPT x 3/8 Barbed Fitting	1
14.	Edge Clip Cable Tie	1

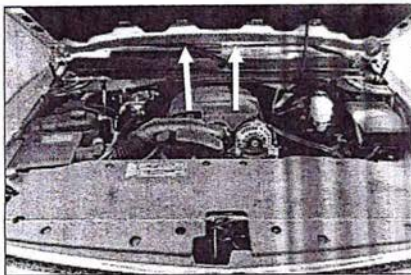

1. **Disconnect the negative battery cable.**
 Remove the engine cover by simply pulling up on it and sliding out from the vehicle.

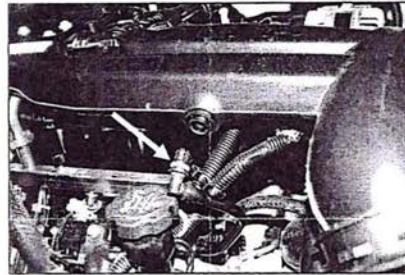

2. Pull the PCV breather line from the factory intake tube.

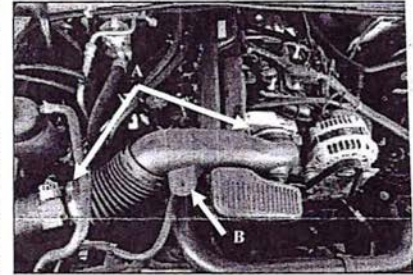

3.A.) Loosen the clamps securing the factory intake tube to the throttle body and the airbox.
 B.) Separate the hose anchor from the factory intake and remove the factory tube.

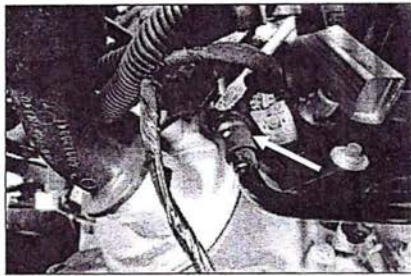

4. Remove the plastic PCV breather line from the factory hard line. A standard screwdriver works well for depressing the locking tab in the coupling.

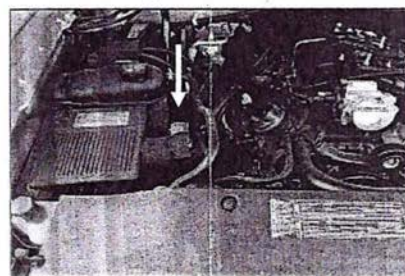

5. Disconnect the Mass Air Flow or MAF sensor and remove the factory airbox from the vehicle. The airbox is secured to the vehicle with grommets and simply lifts out.

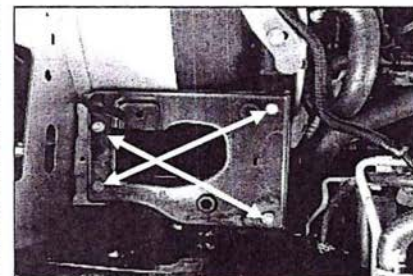

6. Remove the four tray bolts and the airbox mounting tray. Three of the bolts will be reused in step 9.

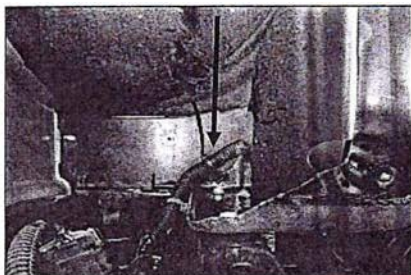

7. Secure the wiring harness to the inner fender as shown using the Edge Clip Cable Tie (#14).

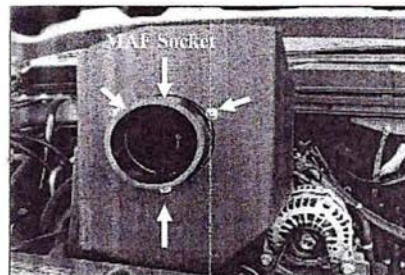

8. Install the Filter Adapter (#4) onto the Cold Air Box or CAB (#3) as shown using the three 1/4-20 Button Head Screws (#10) and 1/4" Flat Washers (#11). Note: The MAF socket is to be in the 12:00 position when properly assembled.

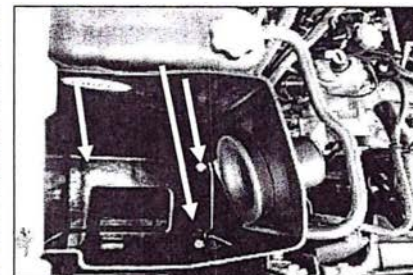

9. Install the CAB (#3) into the engine compartment and secure using three of the tray bolts from step 6.

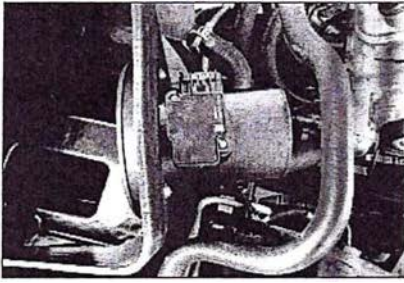

10. Transfer the Mass Air Flow sensor from the factory airbox into the Filter Adapter. Secure the sensor using the two 8-32 Button Head Screws (#9).
Do Not Use Factory Hardware !

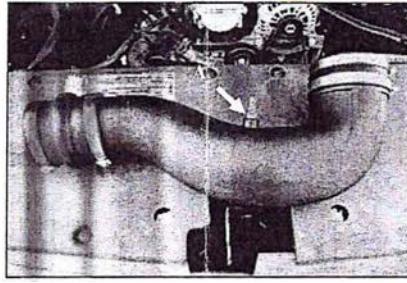

11. A.) Install the 3/8 NPT Fitting (#13) in to the Airaid Intake Tube.

B.) Install the Hump Hose (#5), Coupler (#6) and Hose Clamps (#13) on to the Intake tube as shown. Leave the Clamps loose for now.

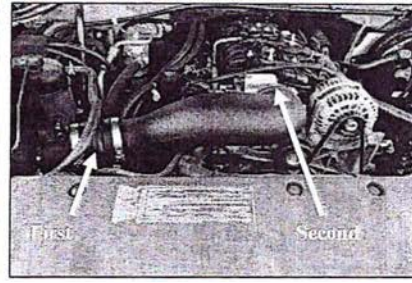

12. Install the Intake Tube assembly onto the Filter Adapter first, and then onto the throttlebody. Adjust for fit, and tighten all hose clamps. Reinstall the hose anchor into the Intake Tube.

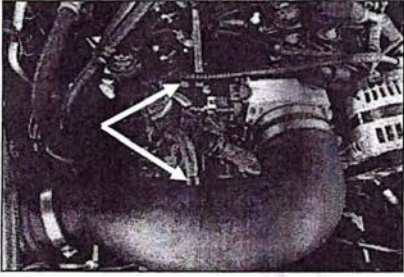

13. A) Install the 3/8" Breather Hose (#7) onto the Barbed Fitting and factory hard line.

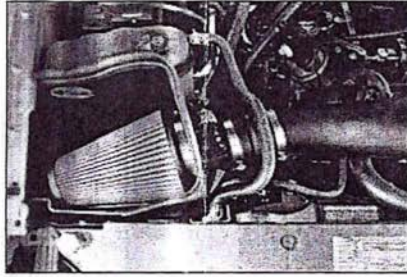

14. Install the Windstorm Premium filter (#1) onto the Filter Adapter, and tighten the hose clamp. Install the Weather Strip (#8) onto the Cold Air Box. Reconnect the M.A.F. sensor. *(Hint: Start from one corner and work your way around for ease of install.)*

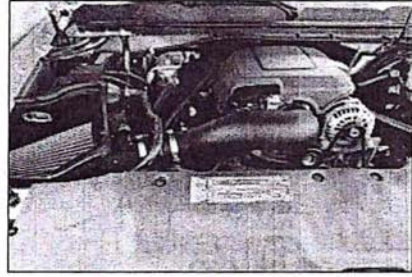

15. Reinstall the engine cover.

Double check your work!

Make sure there is no foreign material in the intake path. Make sure all clamps, hoses, bolts, and screws are tight. Double check the hood clearance.

Reconnect the negative battery cable!