

NOTE:

"Any time an overhead rack is mounted on a vehicle, there will be some incremental wind noise. In the vast majority of cases, the additional noise is subtle and not objectionable. Sometimes, for reasons we cannot explain, customers complain that the wind noise is intolerable. For these customers, we offer this Optional Wind Deflector. Be sure to specify the Wind Deflector part number that is appropriated for your Congo Cage. #60161 for JK Congo Cage #50341 & #50351 ."

**HARDWARE KIT FOR
JK CONGO CAGE
ASSEMBLY**

50341
HARDWARE KIT # 50351

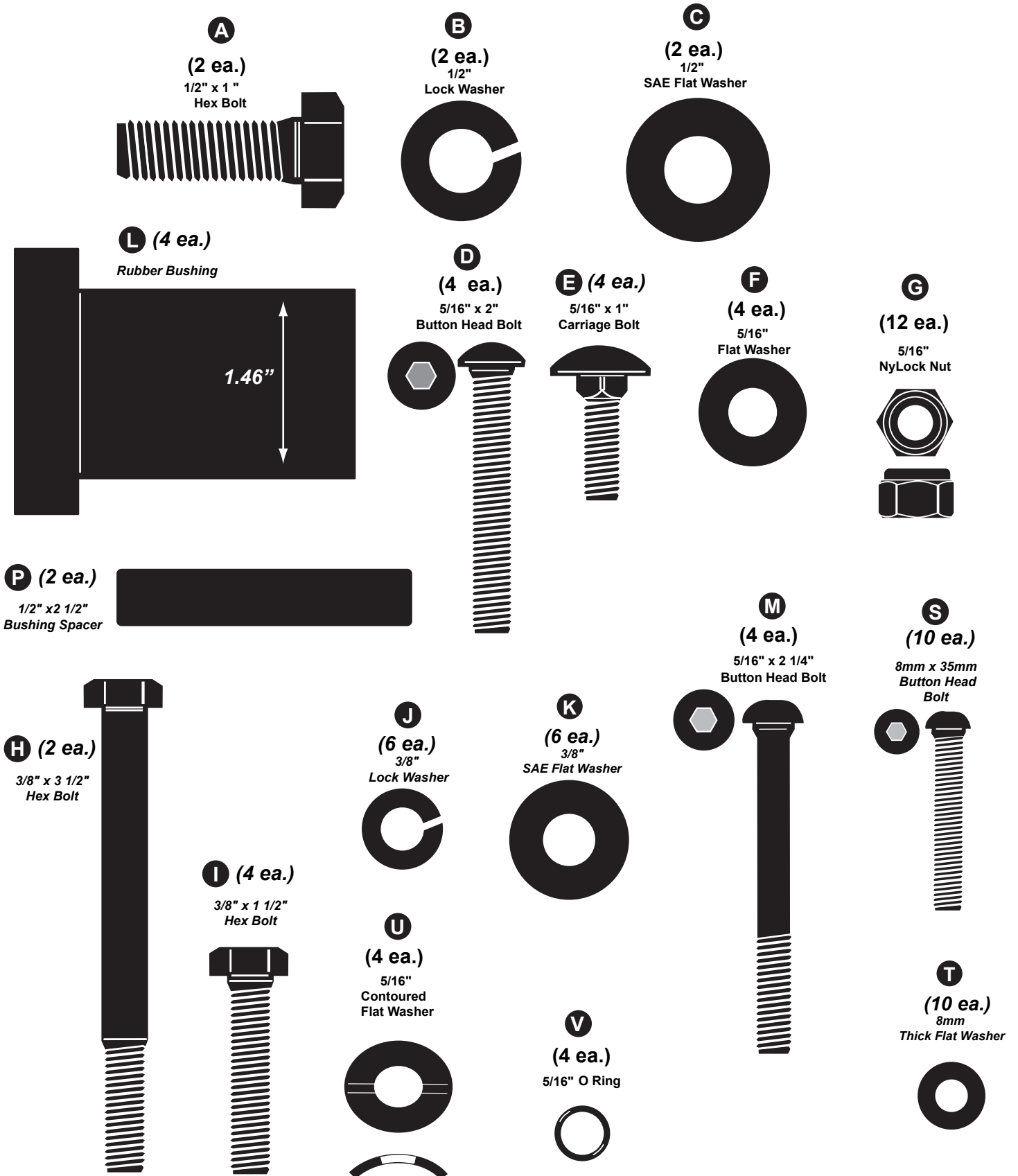

ASSEMBLY & MOUNTING INSTRUCTIONS for JK CONGO CAGE

#1= Remove existing bolts from the upper half of the windshield hinge plates. Put a small bead of silicone inside and around the countersunk bolt holes in the existing windshield hinge plates and place the thick washers **T**, (between the jeep and the bracket), then attach front leg mount plates with bolts **S**.

#2= Under the Jeep, on either side, there is a bracket that attaches the rear bumper to the chassis. Remove existing bolts. Place the Congo Cage rear mounting bracket over the existing bumper bracket. Insert bolts **I** with lock washers **J** and flat washers **K** through the Congo Cage bracket and the Jeep bumper bracket, into the threaded holes in the chassis. Attach loosely.

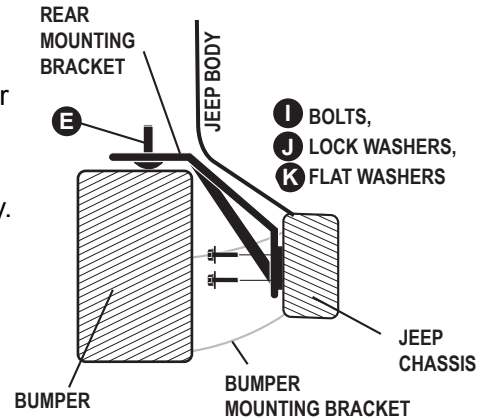

#3= Put bolts **E** up through the foot of mounting bracket (between the bracket and the bumper). Tighten down the bolts at the chassis.

#4= Place U-bracket onto mounting bracket (threads towards jeep), and attach with flat washers **F** and lock nuts **G**. Tighten down securely.

#5= Before inserting male swage into female swage, apply to both inside (female) and outside (male) of each swaged joint a coat of silicone (provided).



#6= With bolts **D** and lock nuts **G** snug only the front legs **04** to the front U-bar **03** (narrow). Then attach rear legs to rear U-bar **05** (widest) with bolts **D** and lock nuts **G** (leg with the joggle goes on driver side).

#7= Next, using bolts **M**, contoured flat washer **U**, and O-ring **V** (as shown), top side only of the cross bars **07**, with lock nut **G** on bottom side.

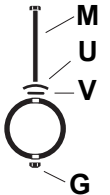

#8= Insert a rubber bushing **L** into one side of each barrel at the bottom of the rear legs and insert bushing spacer **P** into rubber bushing, then insert remaining bushing. Lift rack onto jeep and secure loosely front legs to front mounting brackets with bolts **A**, lock washers **B**, and flat washers **C**. Next attach loosely the rear legs with bolts **H**, lock washers **J** and flat washers

K Tighten down all nuts & bolts and apply bead of silicone around all swage joints as shown below.

(WITHOUT SEALANT)

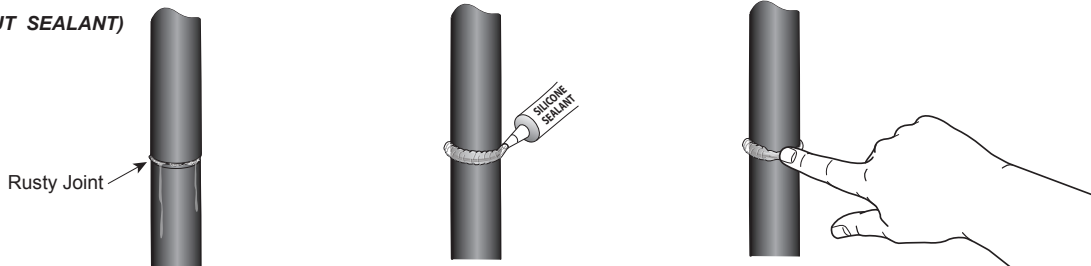

Apply a healthy air tight bead of silicone around every swaged joint to prevent moisture from leaking into and out of the joint. If this is not done properly, the inside surface of the tubes can rust and rusty water can leak out. Maintain this joint seal throughout the life of your rack.

THAT'S IT! You are now ready to use your rack.

NOTE: To remove and replace the soft top to the jeep, remove the front mount bolts and lift the front of the rack and prop it up with the prop rod while you work on the roof. On completion, lower rack back into position and re-bolt.

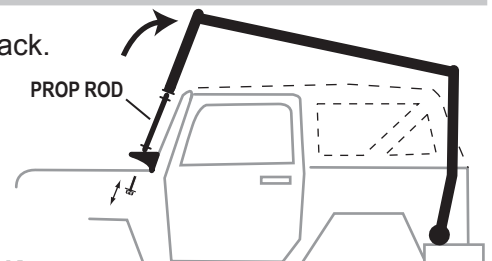

SEE PAGE 4 TO ATTACH BASKET RACK.

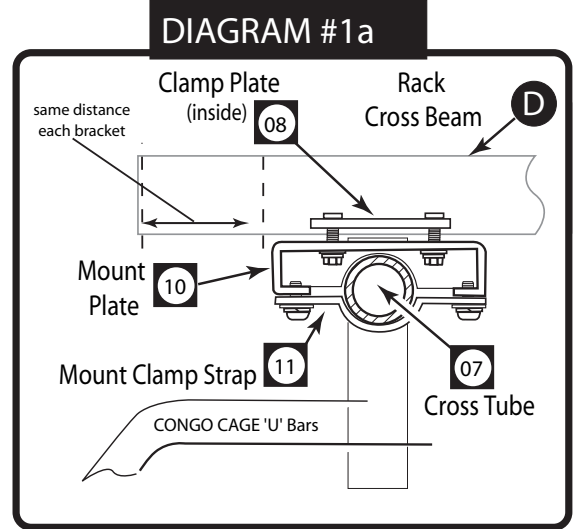
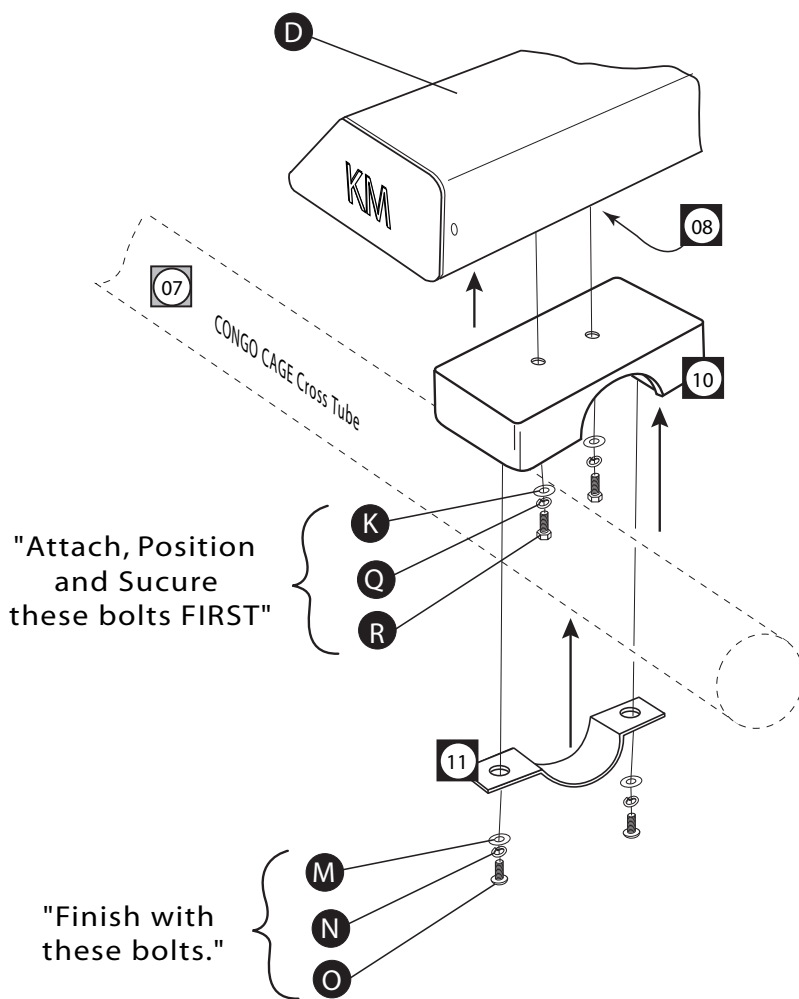

HARDWARE KIT FOR CONGO CAGE MOUNT

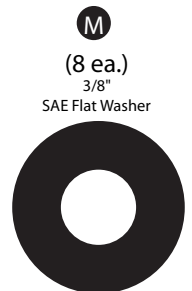
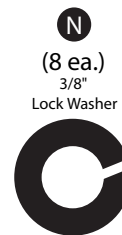
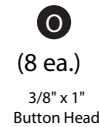
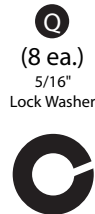

Shown Actual Size