



MODELS 42630 & 42631 PAR-MAX™ 1

a xylem brand

AUTOMATIC WATER SYSTEM PUMP AND MANUAL DEMAND PUMP

FEATURES

- Self-Priming
- Dry Running
- Automatic Operation 42630-2900
- Manual Demand 42631-2900
- Meets U.S.C.G. Electrical Requirements

SPECIFICATIONS

- Motor:** Permanent Magnet, Thermally Protected, Intermittent Duty.
- Pump:** Two chamber opposed double diaphragm design; Self-priming up to 4 ft. suction lift; Pump able to run dry without damage; Intermittent duty.
- Port:** Pump housing inlet and outlet are 3/8" hose barb.

Pump Series	Dimensions - Inches (mm)			Weight
	Height	Weight	Length	Lb. (kg)
42630-2900	2.28 (58)	3.5 (89)	6.37 (162)	1.3 (0.60)
42631-2900	2.28 (58)	3.5 (89)	5.37 (136)	1.2 (0.55)



Models 42630 & 42631 PAR-MAX™ 1

OPERATION FOR WATER SYSTEM PUMPS

The JABSCO PAR-MAX™ 1 series pumps are available as automatic and manual demand pumps. The 42630-2900 will automatically turn on when a fixture is opened and turn off when all fixtures are closed. The 42631-2900 is a manual demand pump for use with an electric faucet.

When starting up an automatic demand pump with a completely dry system, allow time for the demand pump to fill the system. Open a faucet, allow air to vent and close faucet when water flow is steady. Faucet strainers and aerators should be cleaned regularly.

MODEL	VOLTS	AMP DRAW	FUSE*	FLOW	PRESSURE SWITCH psi	
		@10 psi (0.7 bar)	REQUIRED	GPM (min.)	ON	OFF (BAR)
42630-2900	12V dc	1.9	4A	1.1 (4.3)	22 (1.5)	35 (2.4)
42631-2900	12V dc	1.9	4A	1.1 (4.3)	No pressure switch	

AUTOMATIC WATER SYSTEM INSTALLATION

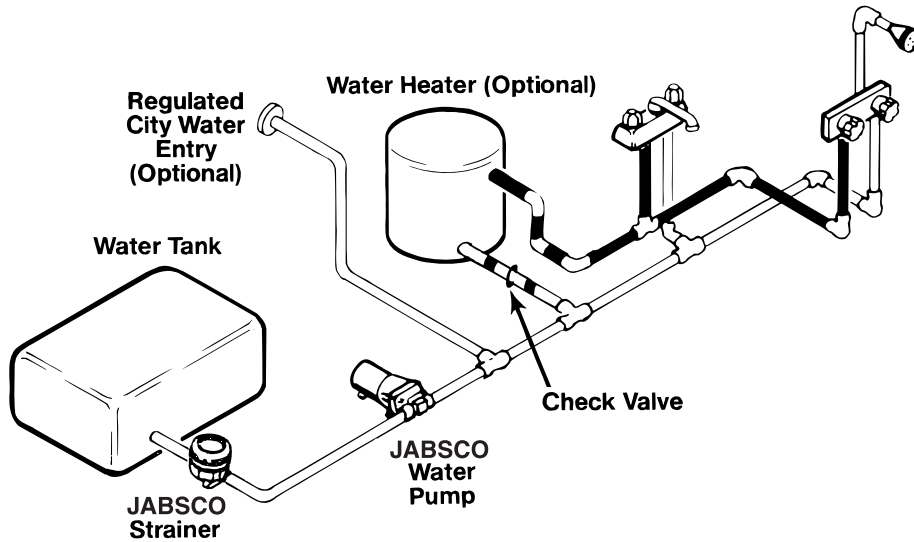

MANUAL WATER SYSTEM INSTALLATION

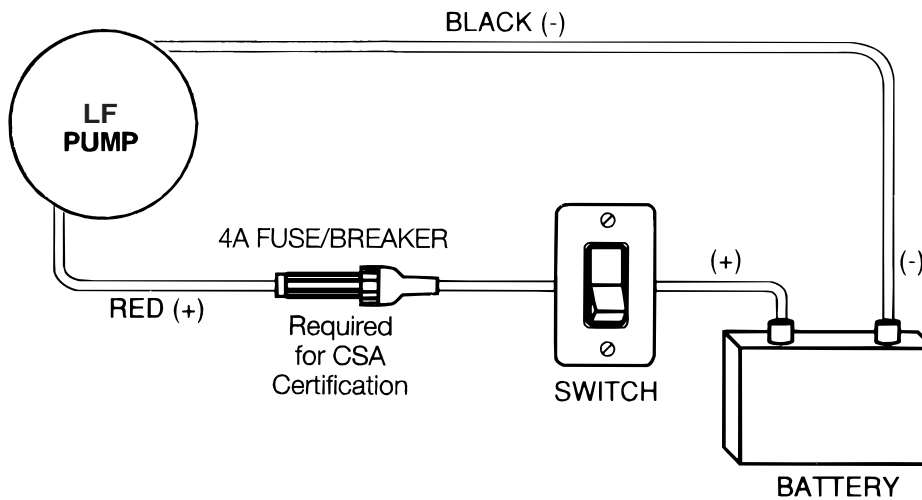

INSTALLATION

1. Remove shipping caps from pump ports. Some water from factory testing may spill out.
2. Mount pump vertically, with pump head down or horizontally in an accessible location. Do not compress feet with mounting screws.
3. Use 3/8" I.D. flexible hose (preferably braided or reinforced). Use hose clamps on the slip-on hose barb connectors.
4. Install a Jabsco inlet 40 mesh strainer in an accessible location (for inspection and cleaning) between the tank and pump inlet. This strainer or equivalent is required for pump warranty to be valid.

In an easily accessible location, install a switch to control electricity to the pump. Turn the pump off when not in use for extended periods, when traveling or when tank is out of water.

A 4 amp fuse should be installed in the positive lead with the pump being its only load.

Wire size based on total wire length, both positive and negative leads.

0 – 30 ft.	#16 AWG
0 – 60 ft.	#14 AWG
0 – 80 ft.	#12 AWG

TROUBLESHOOTING

WARNING: BEFORE SERVICING PUMP, TURN OFF PUMP AND DRAIN WATER FROM SYSTEM!

Problem	Solution
Pulsating Flow – Pump cycles on and off	Restricted pump delivery. Check discharge lines, fittings and valves for clogging or restrictions.
Failure to Prime – Motor operates, but no pump discharge	<ol style="list-style-type: none">1. Restricted intake or discharge line. Open all fixtures, check and clean clogged inline strainer.2. Air leak in intake line3. Punctured pump diaphragm (water leak)4. Defective pump check valve5. Crack in pump housing6. Debris in check valves
Motor Fails To Turn On	<ol style="list-style-type: none">1. Pump switch in off position2. Pressure switch failure3. Loose wiring connection4. Defective motor5. Blown fuse6. Thermal overload (let cool)
Pump Fails to Turn Off After All Fixtures Are Closed	<ol style="list-style-type: none">1. Water tank is empty2. Discharge line leak3. Defective pressure switch4. Punctured pump diaphragm (water leak)
Low Flow and Pressure	<ol style="list-style-type: none">1. Air leak at pump intake2. Accumulation of debris inside pump and plumbing3. Worn pump bearing (excessive noise)4. Punctured pump diaphragm (water leak)5. Defective motor

SERVICE

Pressure Switch Replacement:

1. Remove cap on front of switch and remove the two spade connectors and wire leads.
2. Remove two switch mounting screws and lift switch off pump head.
3. Remove sealing O-Ring and teflon diaphragm (white disk).
4. To replace switch reverse these steps starting with inserting teflon diaphragm, then O-Ring seal before fitting new switch in place.
Take care when replacing screws not to strip out threads in plastic pump housing.

Check Valve and Diaphragm Replacement:

1. Remove 5 screws from top or bottom of pump. But not both top and bottom at the same time. Pry cover loose and lift straight up.
2. Remove spring and inlet valve. Lift front of diaphragm up and remove outlet poppet and smaller spring.
3. Clean the seats and seals and replace them back as they were.

NOTE: Service beyond this is not recommended without factory instructions.

PAR-MAX 1 PUMP SERVICE PARTS LIST

Description	Part	42630-2900	42631-2900
	Number		
Pump head Repair Kit	42632-0000	X	X
Motor/Housing Kit	42633-0000	X	X
Pressure Switch Assy.	42634-0000	X	

STRAINERS

Pump Series	Strainer Number	Inlet	Outlet	Screen
42630-2900	36400-0001	3/8 Barb	3/8 Barb	40 Mesh
42631-2900	36400-0001	3/8 Barb	3/8 Barb	40 Mesh