

Please read and save these instructions. Read through this owner's manual carefully before using product. Protect yourself and others by observing all safety information, warnings, and cautions. Failure to comply with instructions could result in personal injury and/or damage to product or property. Please retain instructions for future reference.



# GreatNeck®

## 6" BENCH GRINDER WITH LAMP

### UNPACKING

After unpacking the Bench Grinder, inspect it carefully for any damage that may have occurred during transit. Check for any loose, missing or damaged parts. If any damage is observed, a shipping damage claim must be filed with the carrier. Do not use the GreatNeck Bench Grinder if broken, bent, cracked or damaged parts (including labels) are noted. Any Bench Grinder that appears damaged in any way, operates abnormally or is missing parts, should be removed from service immediately. If you suspect the Bench Grinder was subjected to shock load (a load that was dropped suddenly, unexpectedly, etc.) immediately discontinue use until it has been checked by a factory authorized service center.



### ⚠ WARNING

The following safety information is provided as a guideline to help you operate your Bench Grinder under the safest possible conditions. Any tool or piece of equipment can be potentially dangerous to use when safety or safe handling instructions are not known or not followed. The following safety instructions are to provide the user with the information necessary for safe use and operation. Please read and retain these instructions for the continued safe use of your tool. Failure to follow instructions listed below may result in serious injury. In addition, make certain that anyone that uses the equipment understands and follows these safety instructions as well.

### Explanation of Safety Signal Words

**⚠ WARNING:** Indicates a potentially hazardous situation which, if not avoided, could result in death or serious injury.

**⚠ CAUTION:** Indicates a potentially hazardous situation which, if not avoided, may result in minor or moderate injury.

**CAUTION:** Used without the safety alert symbol indicates a potentially hazardous situation which, if not avoided, may result in property damage.

**NOTES:** Provide clarity and helpful information.

Thank you very much for choosing a GreatNeck Product!

For future reference, please complete the owner's record below:

**Model:** \_\_\_\_\_ **Purchase Date:** \_\_\_\_\_

Save the receipt, warranty and these instructions. It is important that you read the entire manual to become familiar with this product before you begin using it. This tool is designed for certain applications only. GreatNeck cannot be responsible for issues arising from modification. We strongly recommend this tool is not modified and/or used for any application other than that for which it was designed.



# GreatNeck®

## 6" BENCH GRINDER WITH LAMP



### IMPORTANT INSTRUCTIONS AND SAFETY RULES

1. Know your tool. Read this manual carefully. Learn the tool's applications and limitations, as well as, potential hazards specific to it.
2. Ground all tools. If the tool is equipped with a three-pin plug, it should be plugged into a three-pin electrical outlet. Never remove the ground pin. Do not modify the plug provided. If it will not fit in the outlet, have the proper outlet installed by a qualified electrician. Failure to properly ground unit could result in severe electrical shock and/or death. Always try to avoid body contact with grounded surfaces, such as radiators, cooking ranges and any other fixed appliance with metal surfaces.
3. Do not abuse the electrical cord. Never use the cord to carry tools or pull the plug from an outlet. Keep the cord away from heat, sharp edges or moving parts. Always check the extension cords for damage before use. Replace damaged cords immediately. Damaged cords increase the risk of electric shock.
4. Keep work area clean and well lit. Cluttered or dark work areas invite accidents.
5. Keep children away. All children should be kept away from the work area. Never let a child handle a tool without strict adult supervision.
6. Do not operate this tool if under the influence of alcohol or drugs. Read warning labels on prescriptions to determine if your judgment or reflexes are impaired while taking drugs. If there is any doubt, do not attempt to operate.
7. Use safety equipment. Eye protection should be worn at all times when operating this tool. Use ANSI approved safety glasses. Everyday eyeglasses are NOT safety glasses. Dust mask, non-skid safety shoes, hard hat, or hearing protection should be used in appropriate conditions.
8. Wear proper apparel. Loose clothing, gloves, neck-ties, rings, bracelets, or other jewelry may present a potential hazard when operating this tool. Keep all apparel clear of the tool.
9. Don't overreach. Keep proper footing and balance at all times when operating this tool.
10. Always disconnect the tool from the power source before making any adjustments, storing, servicing, or changing accessories. Such preventative safety measures reduces the risk of starting the tool accidentally.
11. Do not use the tool if the switch does not turn it on and off. Any tool that cannot be controlled with the switch is dangerous and must be repaired.
12. Check for damage. Check your tool regularly. If part of the tool is damaged it should be carefully inspected to make sure that it can perform its intended function correctly. If in doubt, the part should be repaired. Refer all servicing to a qualified technician. Consult your dealer for advice.
13. Keep away from flammables. Do not attempt to operate this tool near flammable materials or combustibles. Failure to comply may cause serious injury or death.
14. Store idle tools out of the reach of children and untrained persons. Tools may be dangerous in the hands of untrained users.
15. Always remain alert when the grinder is in use. Not paying attention to what you are doing may lead to serious injury.
16. Use only accessories or attachments that are recommended by the manufacturer for your model. Accessories that may be suitable for one tool may become hazardous when used with another tool. Use of non-recommended accessories may result in injury or damage to the tool.

### Power Tool Safety

1. Do not expose your power tool to wet or damp conditions and NEVER use in rain. Regularly check the power cord of your tool and any extension cord that you are using for damage.
2. Do not carry or pull the machine with the power cord. Ensure the cord is clear from hot surfaces, oil or sharp objects.
3. Before plugging your power tool into the power outlet, make sure the power tool is in the OFF position.
4. Check that wrenches or adjusting keys have been removed. Any wrench or key left attached to a moving part can result in injury.
5. Keep your power tool clean and well serviced at all times.
6. Always use the correct tool for the job and never force the tool to work harder than it is designed.
7. Never use your power tool with broken parts such as switches, guide fences or leg stands.
8. Only have your power tool serviced by a qualified repair agent using the manufacturer's recommended parts.
9. Do not force the material being cut.
10. Never stand on a tool.
11. Never leave a tool running unattended.
12. Use the proper extension cord.
13. Avoid prolonged exposure to vibration.

### ⚠️ WARNING

- Only use qualified repair agents to service this power tool.
- Only use qualified electrician to repair any damaged wiring.
- NEVER remove the grounding prong from the power cord or extension cord.

### Ground Tools (Electrical Powered Connections)

Only use qualified repair agents to service this power tool. Only use qualified electrician to repair any damaged wiring. NEVER remove the grounding prong from the power tool or extension cord. This product must be grounded. In the event of a malfunction or breakdown, grounding provides a path of least resistance for electric current to reduce the risk of electric shock. This product is equipped with an electric cord having an equipment-grounding conductor and a grounding plug. The plug must be plugged into a matching outlet that is properly installed and grounded in accordance with all local codes and ordinances. Do not modify the plug provided. If it will not fit the outlet, have the proper outlet installed by a qualified electrician. Check with a qualified electrician or service personnel if the grounding instructions are not completely understood, or if in doubt as to whether the product is properly grounded. Repair or replace a damaged or worn cord immediately. This product is for use on a nominal 120V circuit and has a grounding plug. Only connect the product to an outlet having the same configuration as the plug. Do not use an adapter with this product.

### Extension Cords

When using this tool at a considerable distance from the power source, a conductor, grounding-type extension cord of adequate size must be used for safety and to prevent loss of power and over-heating. For a 120 Volt tool, the minimum size of the wires in any extension cord up to 75 Ft. long must be 18 gauge (American Wire Gauge) if the total extension cord length is from 75 to 100 Ft., 16 gauge wire is required throughout the tension.



# GreatNeck®

## 6" BENCH GRINDER WITH LAMP

**NOTE:** The 16 gauge wire is heavier than the 18 gauge and will carry current for a longer distance without a voltage drop. Use only 3 wire extension cords which have 3 prong grounding type plugs and 3 hole receptacles which accept the tools plug. Replace or repair damaged or worn cord immediately.

### Purpose

The GreatNeck 6 In. Bench Grinder is used for hand grinding operations such as sharpening chisels or screwdrivers, grinding drills, removing excess metal from work pieces and smoothing metal surfaces. It features ball bearing construction for smooth operation, adjustable and shatterproof eye shields, spark breakers, tool rests and removable wheel guards. It has a goose neck lamp to illuminate the work area.

### Specifications:

Power: 120V

Motor: 1/3 HP

Speed: 3,400 RPM

Weight: 22 Lbs.

Tool Rests: Adjust to 45 or 90 Degree Positions

6 In. Wheels: Coarse 36 and Medium 60

### ⚠ WARNING

Some dust created by power sanding, sawing, grinding, drilling and other construction activities contains chemicals known to cause cancer, birth defects or other reproductive harm. Some examples of these chemicals are:

- Lead from lead-based paints
- Crystalline silica from bricks and cement and other masonry products
- Arsenic and chromium from chemically-treated lumber

Your risk from these exposures varies, depending on how often you do this type of work. To reduce your exposure to these chemicals, work in a well-ventilated area and work with approved safety equipment, such as those dust masks that are specially designed to filter out microscopic particles.

### Assembly

#### Tool Rests

Attach the left and right tool rests with the (4) 5/8" bolts and large washers. Adjust the rests for a distance of 1/16" from the surface of the grinding wheel.

#### Spark Breakers

Attach the spark breakers with the (2) 5/16" bolts and medium washers. Adjust the spark breaker for a distance of 1/16" from the surface of the grinding wheel. Spark breakers should be installed perpendicular to the grinding wheel. If these are not installed properly, it is an OSHA violation.

#### Eye Shields

Select one of the eye shields. Put its clamp into one of the other spark breaker brackets. Adjust the eye shield to be located in the middle of the wheel to protect the operator from sparks.

### Final Assembly

Fasten the Grinder to the workbench, stand or cabinet. Two holes are provided in the base of the Bench Grinder to attach the grinder securely and prevent it from moving during operation.

### Operation

A Bench Grinder is designed for hand grinding operations such as sharpening chisels or screwdrivers, grinding drills, removing excess metal from work and smoothing metal surfaces. A medium grain abrasive grinding wheel is suitable for rough grinding where a considerable amount of metal has to be removed or where a smooth finish is not important. For sharpening tools or grinding to close limits of size, a fine grain wheel should be used as it removes metal shower and gives the work a smooth finish.

1. Adjust the eye shield.
2. Check for a 1/16" clearance between the tool rests and the grinding wheels and between the spark breakers and the grinding wheels. Adjust as needed. Always keep the tool rest adjusted so that it just clears the wheel and is at the same level or just below the center line of the wheel to prevent accidental jamming of the work between the tool rest and the wheel.
3. Turn the Bench Grinder on and let it come up to speed.

**CAUTION:** When starting the Bench Grinder, turn it on and stand to one side until it has come up to speed. There is always the possibility that a piece from a damaged grinding wheel may be thrown off when coming to full speed.

4. When grinding, always keep the work moving across the face of the wheel. Grinding against the same spot on the wheel will cause grooves to be worn into the face of the wheel. For grinding large or odd shaped work pieces, the tool rests can be removed if needed.
5. When it is necessary to reshape the grinding wheels, use the proper tools. After re-shaping, adjust the tool rests and spark breakers as needed to maintain the 1/16" clearance from the wheel.

### Changing the Grinding Wheel

1. Unplug the bench grinder.
2. Remove the outer wheel guard cover screws and the wheel guard cover.
3. Hold the opposite wheel firmly. Remove the nut and flange.

**NOTE** Turn the spindle nut on the right hand side counterclockwise to loosen. Turn the spindle nut on the left hand side clockwise to loosen.

4. Remove the old wheel and replace it with the new one.
5. Assemble the flange and nut onto the spindle. Tighten the spindle nut just enough to hold the wheel firmly. If the nut is tightened too much, the wheel may be damaged.
6. Attached the wheel guard cover.
7. Turn the grinder on and let it come up to speed and idle for one minute.

### Bench Mounting

Mounting the grinder on a bench is strongly recommended in order to prevent movement of the grinder when pressure is applied against a wheel.

1. Slide rubber feet on both sides and in the middle of the grinder base.
2. Drill 2 holes for 1/4" wood screws or bolts in the bench.
3. Use 1/4" wood screws or bolts and tighten down only enough to partially compress the rubber feet (about 1/16"). The rubber feet will not be effective in absorbing vibration if fully compressed.
4. When using 1/4" bolts, a second nut is required to lock against the first nut and keep the grinder from loosening during operation.
5. Never operate the grinder without the rubber feet attached to its base.



**GreatNeck®**

# 6" BENCH GRINDER WITH LAMP

Item No.	Description	Qty.
1	Grinder Wheel - Coarse	1
	Grinder Wheel - Fine	1
2	Inside & Out Wheel Guard Assembly	2
3	Eyeshield Assembly for Right & Left Side	1
4	Base	1
5	Switch	1
6	Tool Rest Assembly for Right & Left Side	1
7	Lamp Assembly	1

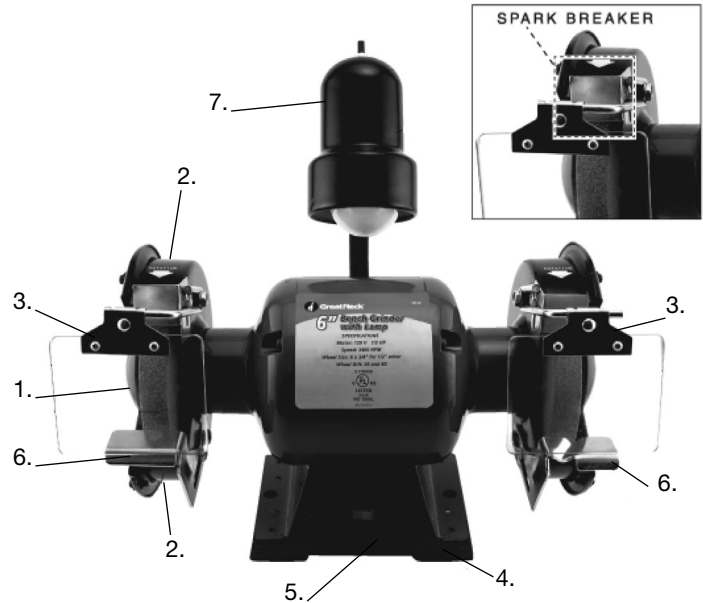

GreatNeck and/or its distributors have provided the parts list and assembly diagram as a reference only. Neither GreatNeck and/or its distributors make any representation or warranty of any kind to the buyer and/or user of this tool that he or she is qualified to do any repairs or replace any parts of this product. GreatNeck and its distributors expressly state that all repairs or part replacements should be done by certified or licensed technicians. The buyer assumes all risk and liability arising out of his or her repairs or parts replacement to the original product.

## GreatNeck® ONE YEAR LIMITED WARRANTY

GreatNeck does not provide any warranty for products labeled other than GreatNeck Tools LLC. GreatNeck will not provide any warranty for products subjected to abnormal use. Abnormal use includes, but is not limited to, abuse, accident, alteration, neglect, and unauthorized or unreasonable use or repairs. This warranty does not cover blades, bits, files, sheathes, cases, accessories, bulbs, batteries, calibration, or finishes. We recommend that you maintain your tools and sharpen or replace blades, batteries, bits and files as necessary. GreatNeck reserves the right to make any changes in construction or design at any time without any obligation in incorporating such changes to tools or equipment previously sold.

GreatNeck is not liable for consequential or incidental damages arising from the breach of this, or any other, warranty whether expressed, implied, or statutory. Some states do not allow the exclusion or limitation of incidental or consequential damages, so the above exclusion may not apply to you. This warranty gives you specific legal rights, and you may also have other rights, which vary from state to state.