

GOBI JEEP JK WRANGLER ROOF RACK QUICK RELEASE INSTALLATION INSTRUCTIONS

Guidelines:

When using Load Carriers and Accessories, the user must understand the precautions. The points listed below will assist you in using the rack /carrier system and will encourage safety.

- For quality fits and safety, use only the recommended rack or accessory. Do not assume an accessory will fit, always check with dealer when obtaining new accessories. Use only approved accessories on load carriers. Using other brands will void your warranty.
- Make sure all knobs, bolts, screws, straps, and locks are firmly attached, tightened and locked before every trip. Knobs, bolts, screws, straps, and locks must be periodically inspected for signs of wear, corrosion, and fatigue. Check your load at stops during the trip to insure continued fastening security.
- Check local and state laws governing projection of objects beyond the width of a vehicle. **Be aware of the width and height of your cargo since low clearance branches, bridges, and parking garages can affect the load** All cargo will affect the vehicle's driving behavior. Never drive with any lock, knob, or rack in an open or unlocked position. All long loads such as, but not limited to sailboards, surfboards, kayaks, canoes, and lumber must be tied down front and rear to the bumpers or tow hooks, of the vehicle.
- Remove your rack accessories when they are not in use, before entering car washes, prior to taking in your vehicle for service, and whenever clearance may be an issue.
- All locks must be turned and moved periodically to insure smooth operation. Use graphite or similar dry lubricant to help this. Locks are designed to deter vandalism and theft. Remove valuable gear if your vehicle is unattended for an extended period. Place at least one key in the glove compartment.
- For safety to your vehicle and rack system, obey all posted speed limits and traffic cautions. Adapt your speed to the conditions of the road and the load being carried.
- Do not use load carriers and accessories for purposes other than those for which they were designed. Do not exceed their carrying capacity.
- Consult with your dealer if you have any questions regarding the operations and limits of this product. Review all instructions carefully.

“CAUTION”

Roof rack must not be released /pulled back when cargo is present on roof rack or persons are seated within the vehicle. Remove all cargo and vehicle occupants prior to roof rack retraction and reattachment. Always use two persons when using the “Quick Release” system to aid in the release and reattachment process of the roof rack.

GOBI JEEP JK WRANGLER ROOF RACK QUICK RELEASE INSTALLATION INSTRUCTIONS

Included in kit

Letter	Description	Location	Quantity
A	GOBI JEEP JK ROOF RACK QUICK RELEASE PASSENGER AND DRIVES SIDE	Main box	1 ea.
B	SAFETY TETHER STRAP 4-DOOR (112" LONG) SAFETY TETHER STRAP 2-DOOR (97" LONG) (enclosed safety tether will be based upon a 2 or 4 door vehicle) (Please specify when ordering)	BAG #1	1

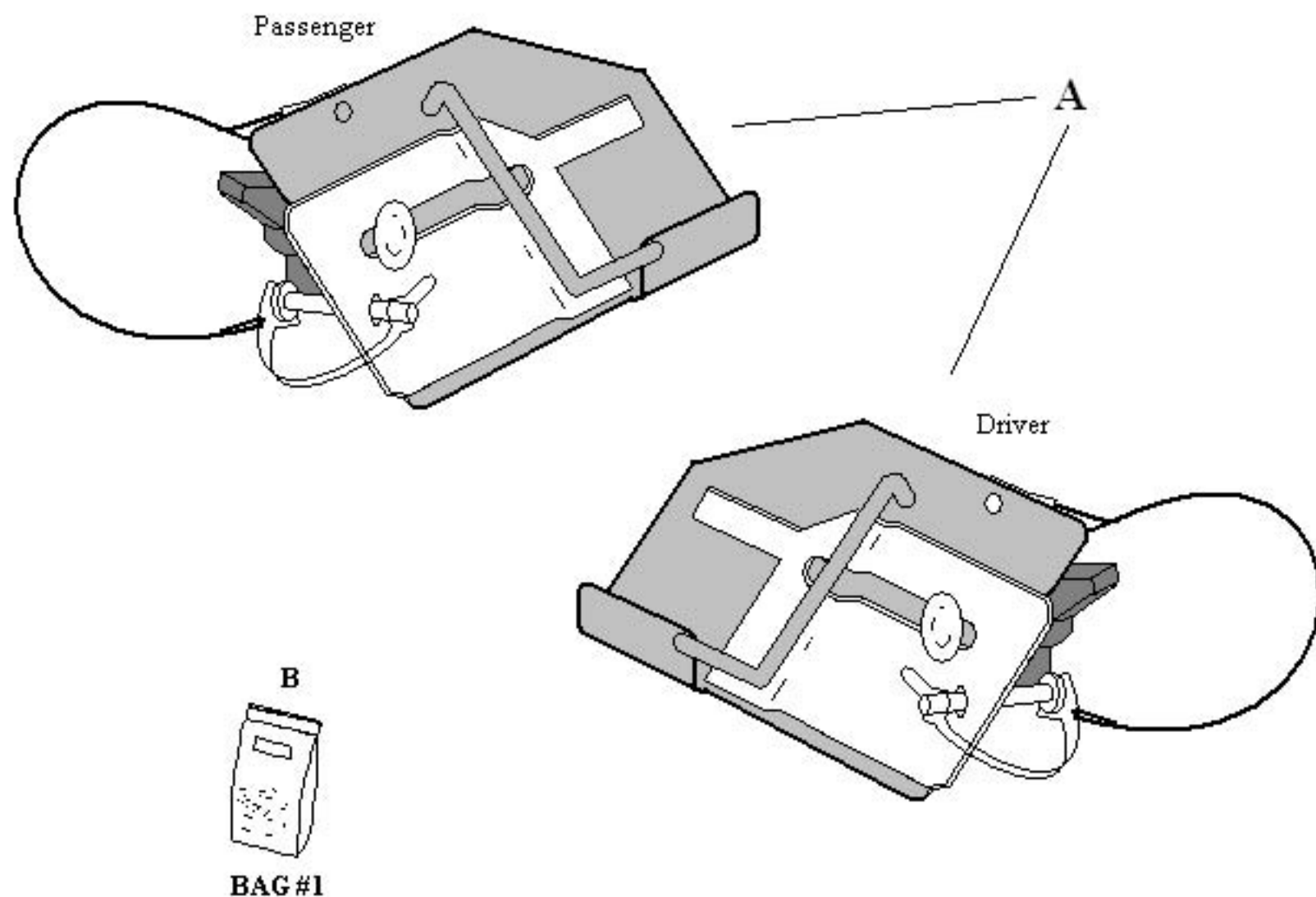

GOBI JEEP JK WRANGLER ROOF RACK QUICK RELEASE INSTALLATION INSTRUCTIONS

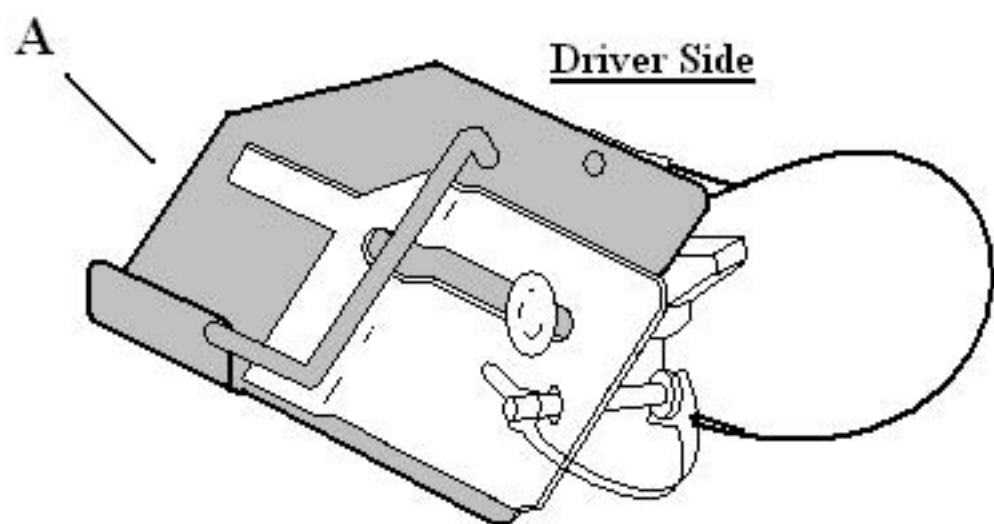

QUICK RELEASE BREAK DOWN

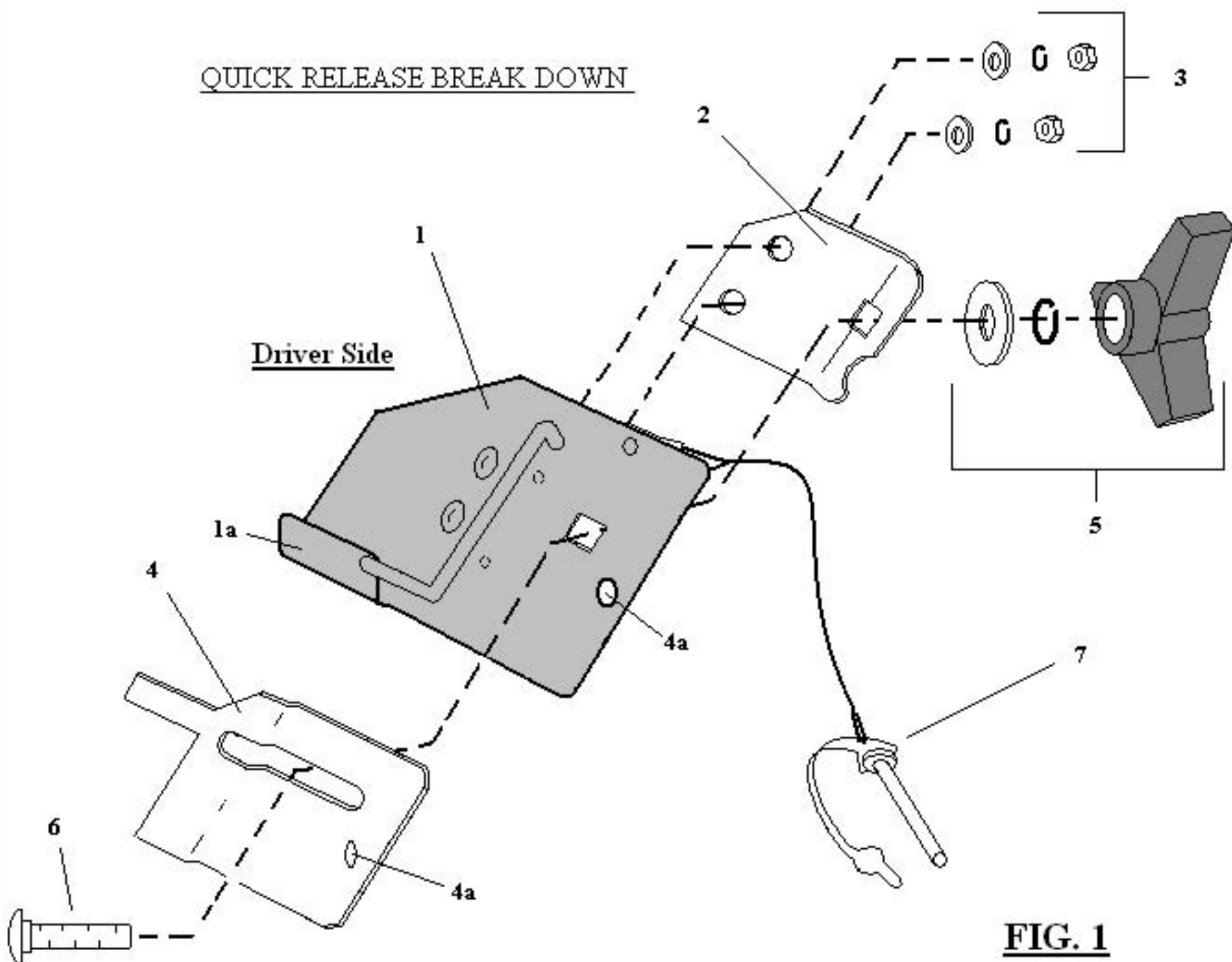

FIG. 1

GOBI JEEP JK WRANGLER ROOF RACK QUICK RELEASE INSTALLATION INSTRUCTIONS

ASSEMBLY OF QUICK RELEASE ONTO LIGHT BAR

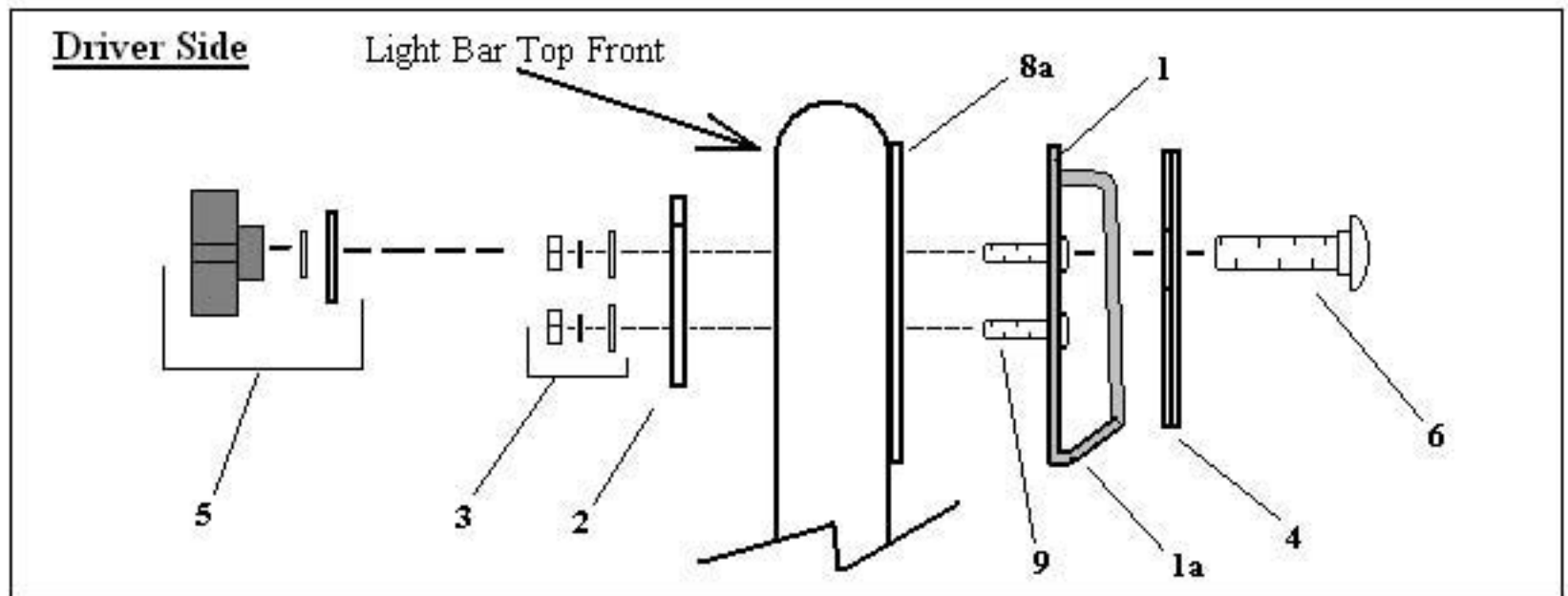

FIG. 2

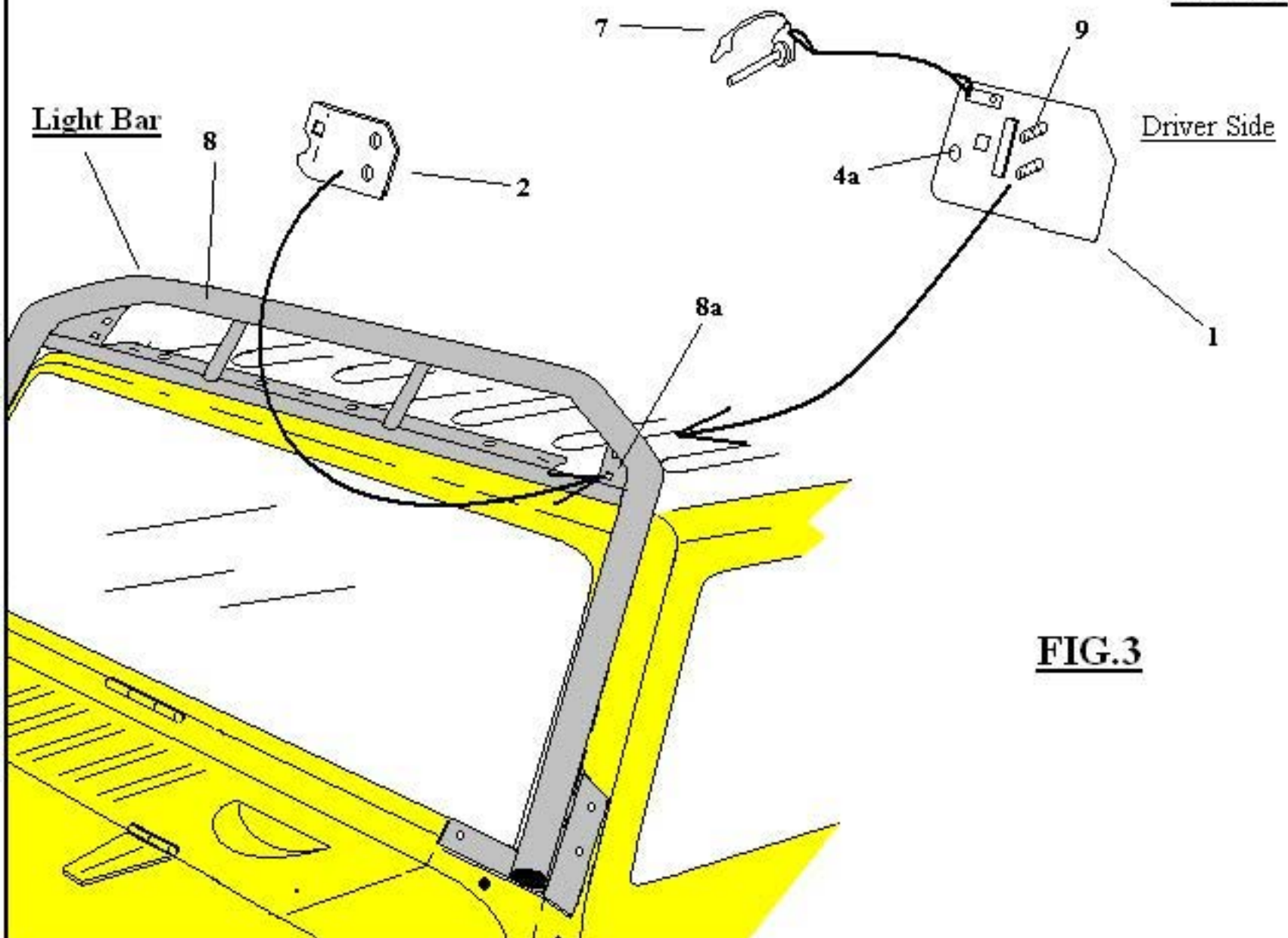
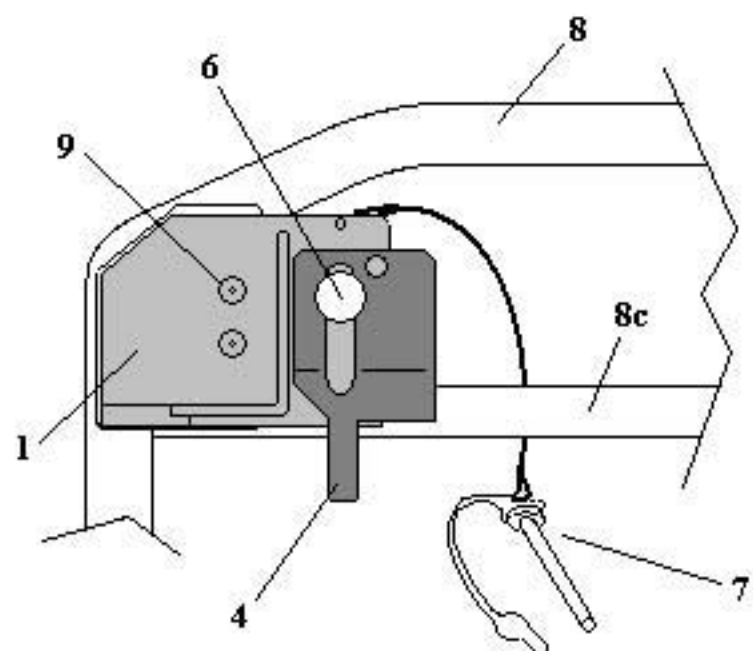

FIG. 3

GOBI JEEP JK WRANGLER ROOF RACK QUICK RELEASE INSTALLATION INSTRUCTIONS

Step 1



REAR VIEW OF UPPER DRIVER SIDE LIGHT BAR

Step 2

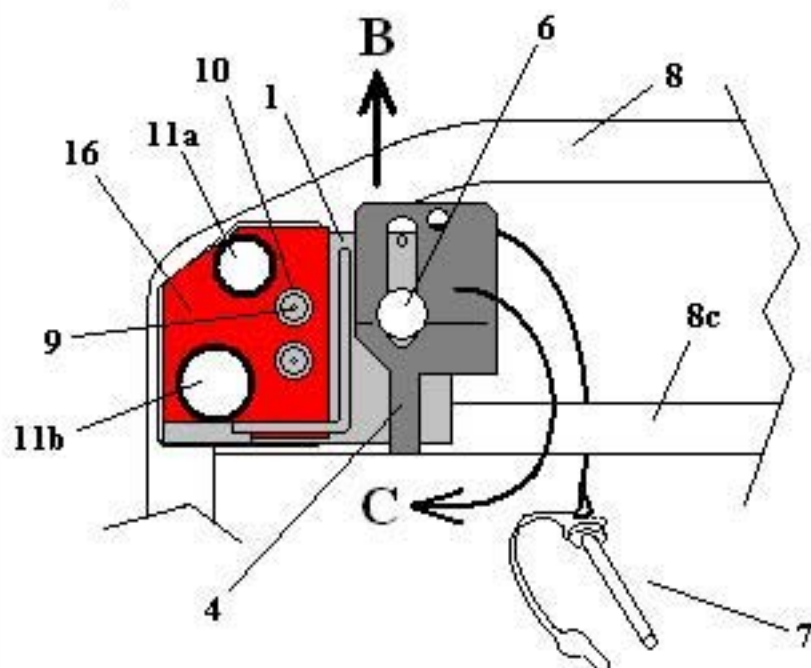

REAR VIEW OF UPPER DRIVER SIDE LIGHT BAR

Step 3

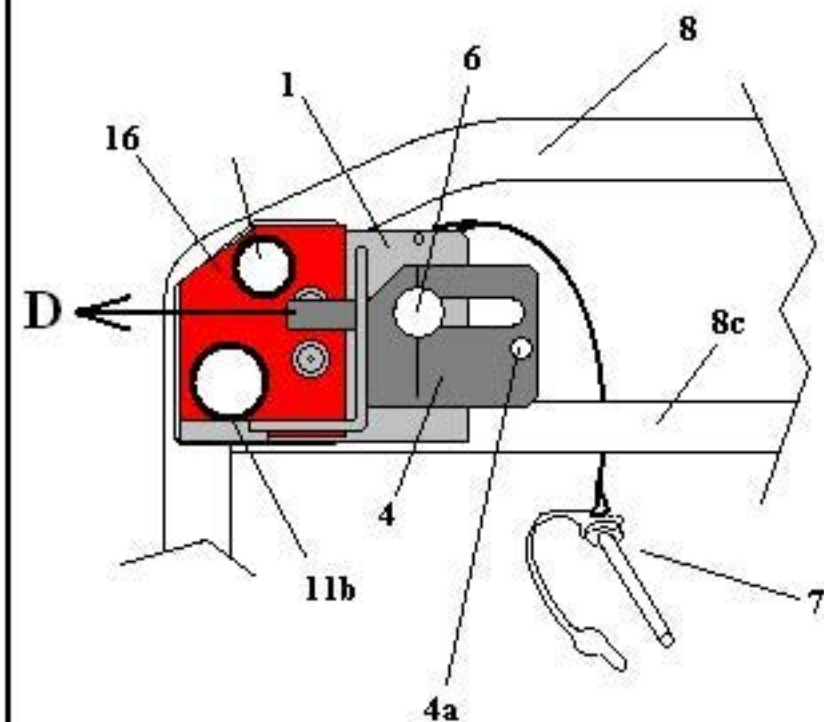

REAR VIEW OF UPPER DRIVER SIDE LIGHT BAR

Step 4

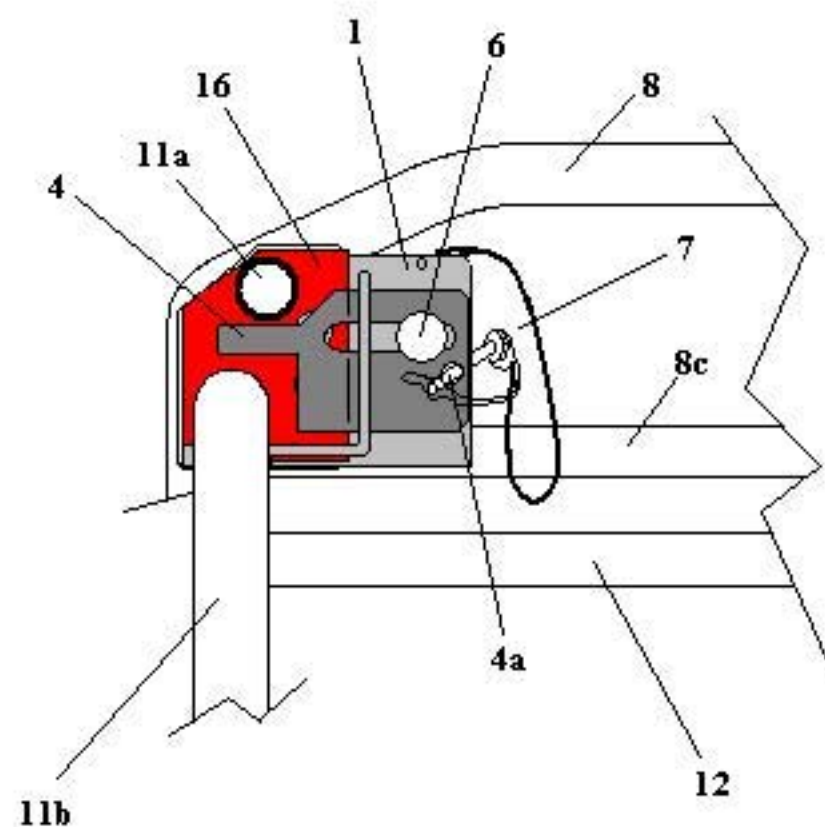

REAR VIEW OF UPPER DRIVER SIDE LIGHT BAR

GOBI JEEP JK WRANGLER ROOF RACK QUICK RELEASE INSTALLATION INSTRUCTIONS

Roof Rack

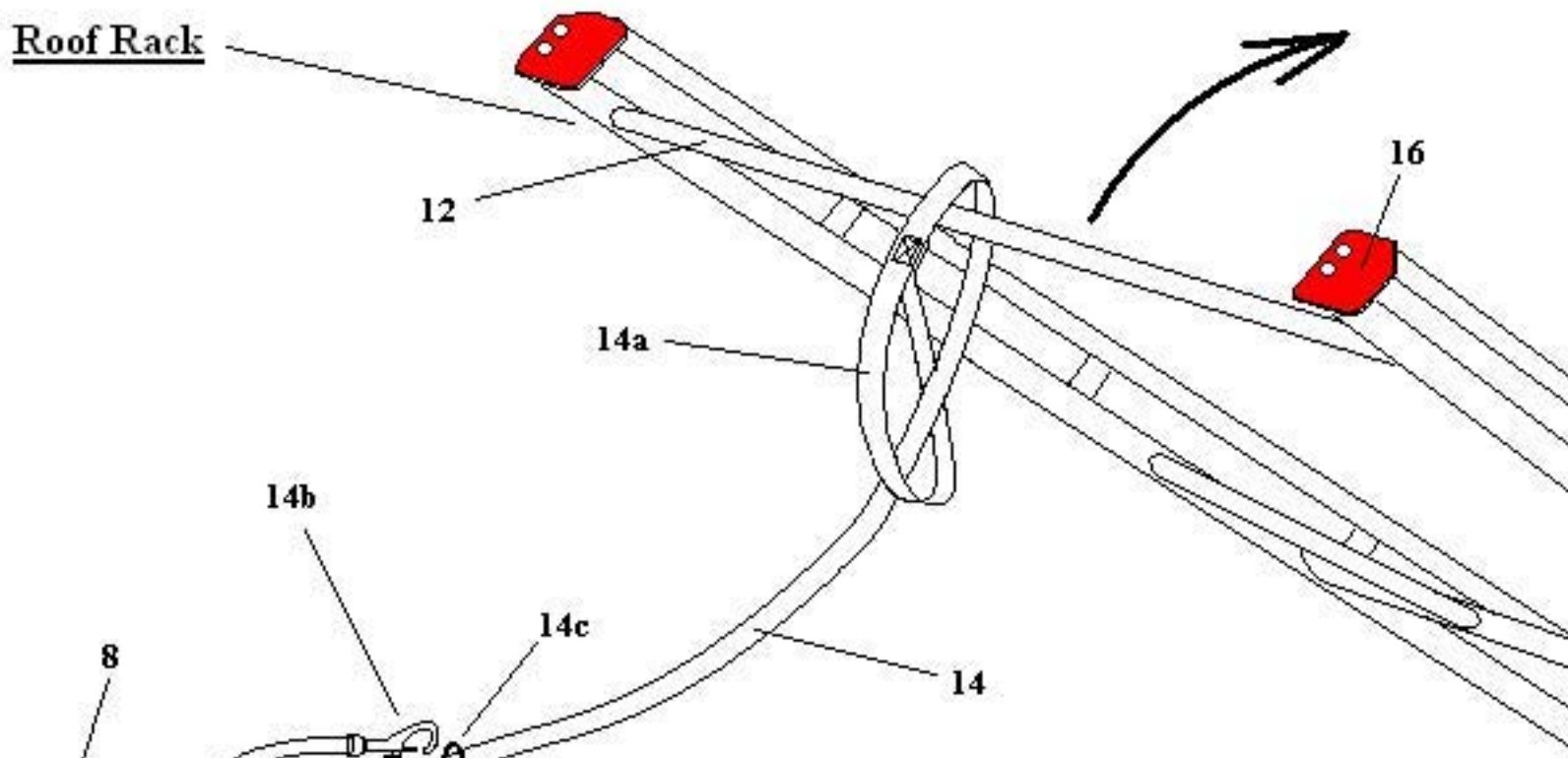

Light Bar

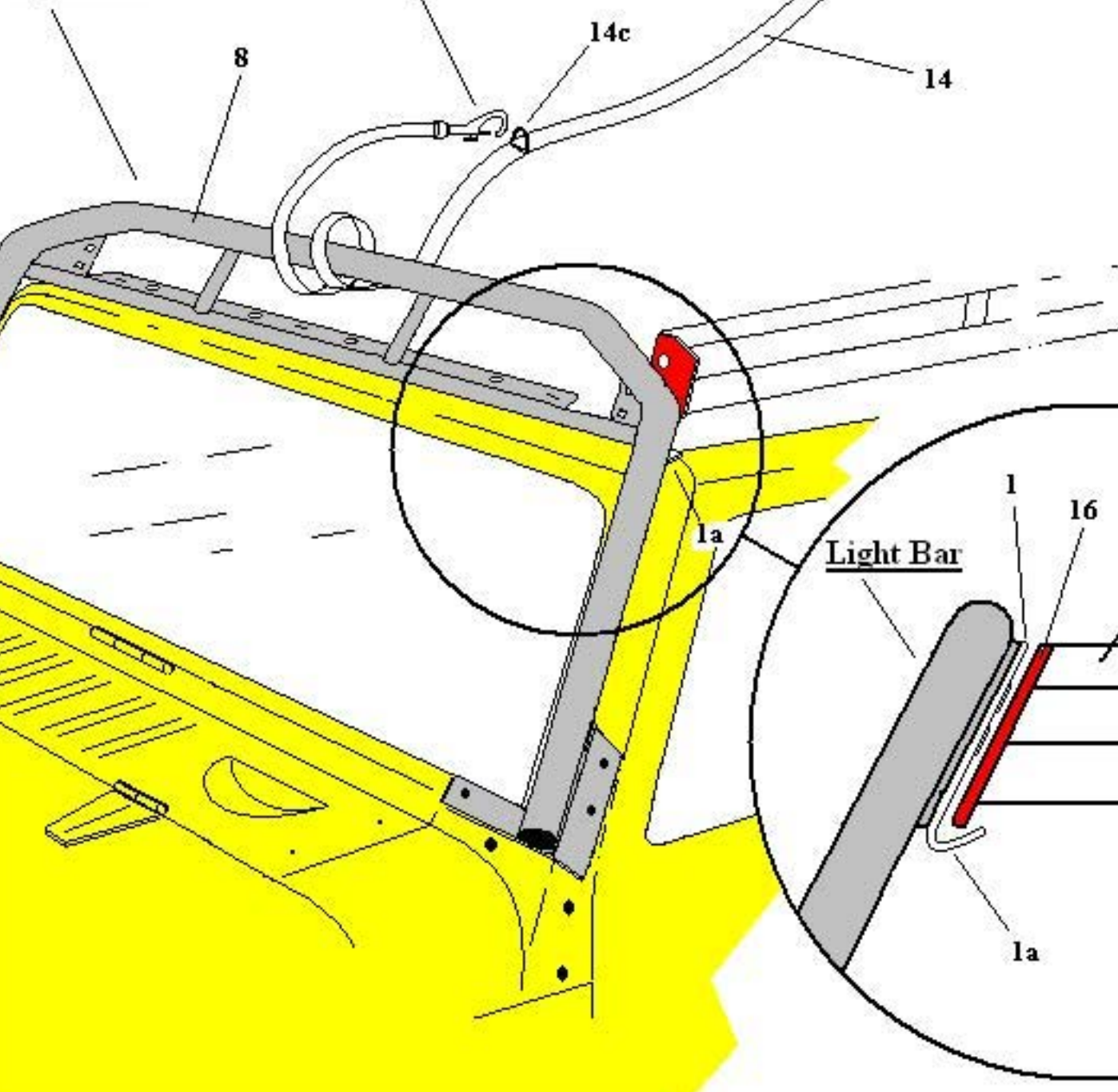

FIG. 4

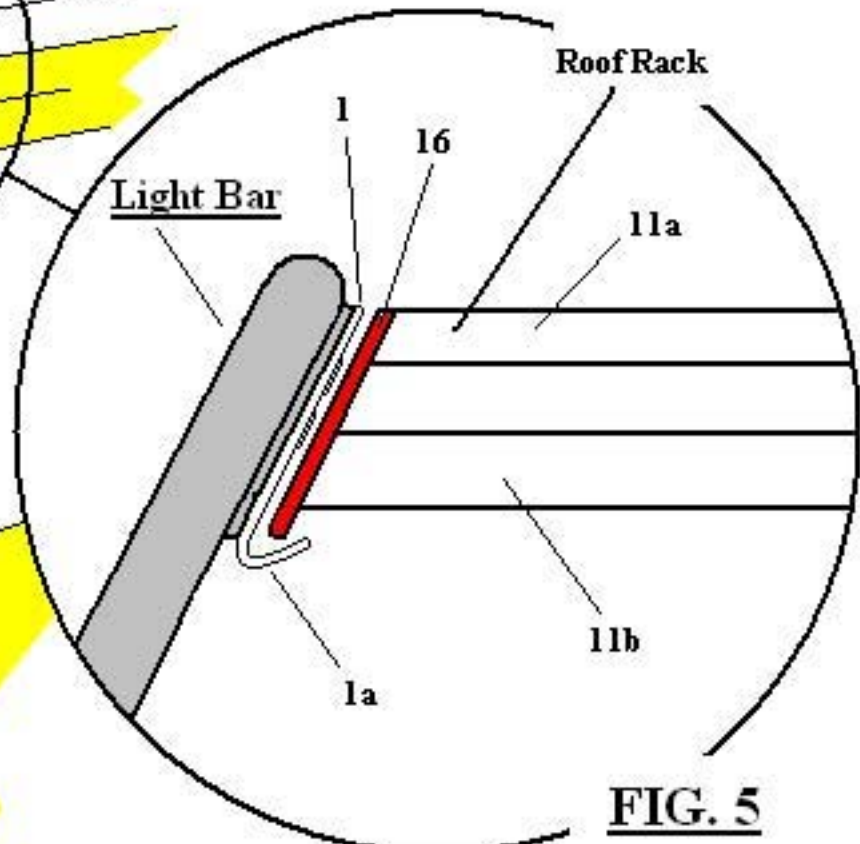

FIG. 5

GOBI JEEP JK WRANGLER ROOF RACK QUICK RELEASE INSTALLATION INSTRUCTIONS

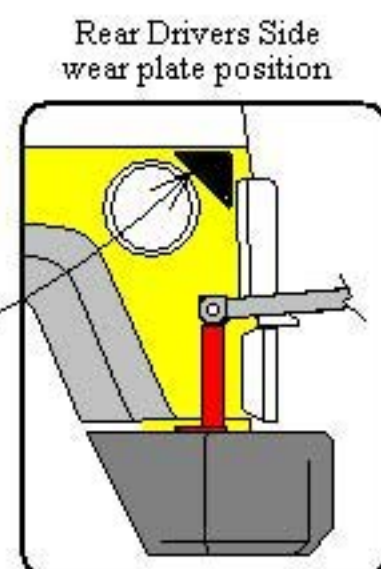
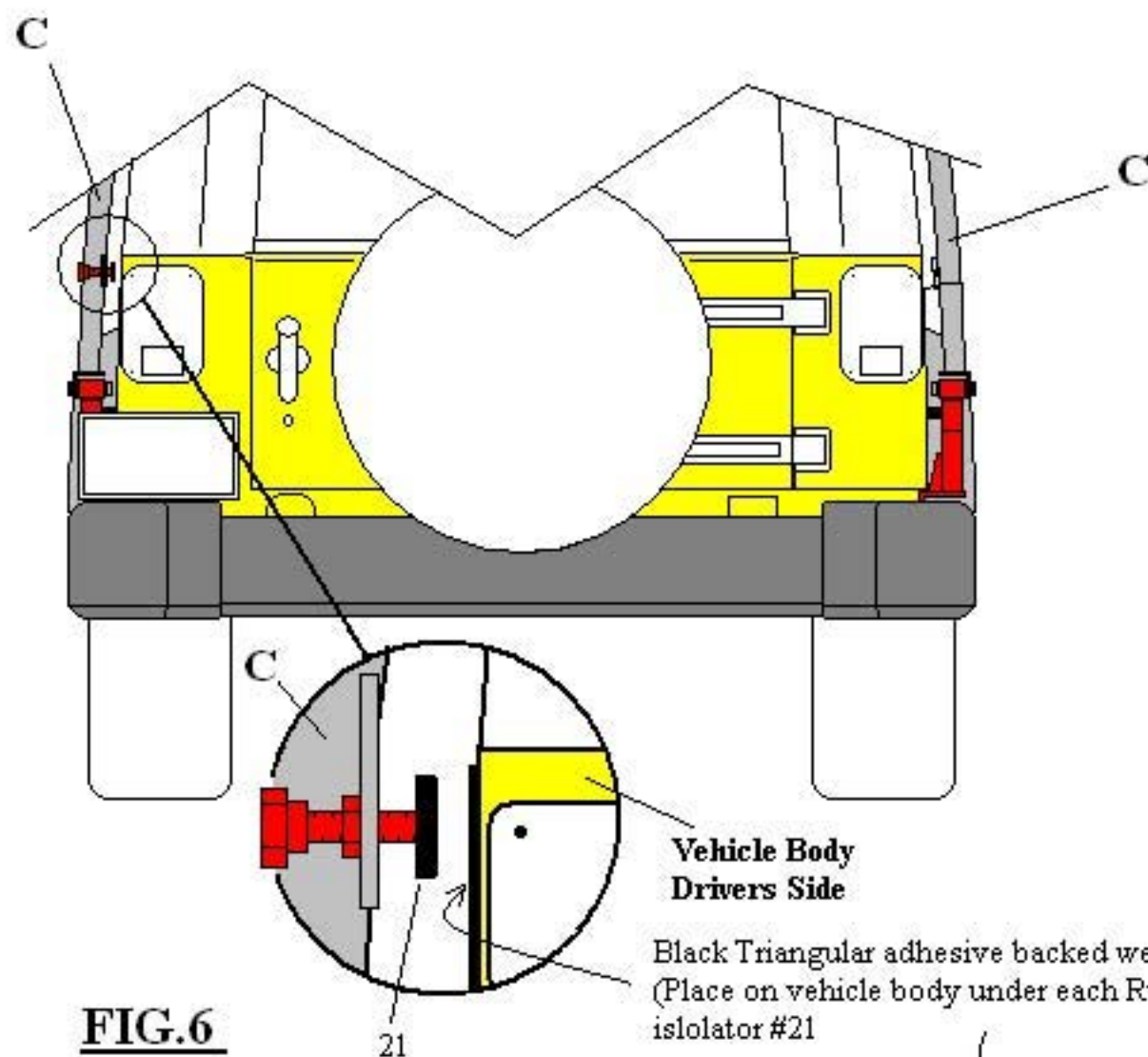

FIG. 7

GOBI JEEP JK WRANGLER ROOF RACK QUICK RELEASE INSTALLATION INSTRUCTIONS

The rack must be inspected before each use to make certain attachments are secure, and for evidence of Wear. Misuse of the rack or failure to observe the manufacturer's instructions as to installation, proper Attachment and maintenance will void any warranties that may be implied by law.

INSTALLATION INSTRUCTIONS:

- 1- Refer to page 2 make sure all hardware listed is present prior to installation.
- 2- Read all instructions carefully prior to installation.
- 3- Prior to attaching your "Quick Release" with the roof rack still bolted to your light bar remove any cargo you may have on your roof rack then Refer to page 6 Fig 4 and attach Safety Tether (14) supplied with your kit handle end (14a) first to roof rack cross bar (12) as shown. Continue by wrapping the opposite end of the Safety Tether (14b) twice around the light bar as shown then connecting hook end (14b) to "D" ring (14c) pull both ends taut around tubing.
- 4- Refer to page 7 Fig. 6 and fully loosen anti-sway rubber tipped adjustable bolts (21) completely away from vehicle side body both driver and passenger sides. *Note: Make certain you retain the triangular wear plates under each adjustable anti sway rubber tipped bolt when attaching your "Quick Release" as this will prevent body wear from occurring during the loosening and tightening of the adjustable bolt shown on page 7 Fig 6 and Fig.7.* Place a rag or towel on the roof top of your vehicle below the roof rack plates (16) shown on page 6 Fig. 4. This will prevent any damage to your roof top as you remove the bolts holding the roof rack to the light bar as the roof rack will be resting on the roof top. Take caution and release the roof rack gently onto the roof top of your vehicle. Swing your vehicle spare tire carrier in the open position then gently pull back your roof rack grabbing onto the larger roof rack lower tubing pull back roof rack completely and rest rear end of roof rack onto the top of your spare tire. The "Quick Release" safety tether may be slack at this time.
- 5- Refer to page 3 Fig. 1 and disassemble your Driver side "Quick Release" assembly as shown to prepare for assembly onto light bar.
- 6- Refer to page 4 Fig. 2 and Fig. 3 begin attaching Driver side "Quick Release" saddle (1) by sliding both screws (9) through square holes located on the Light Bar Driver side plate (8a) as shown in Fig. 3. Place clamp (2) as shown onto front side of Light Bar plate (8a) and over "Quick Release" saddle screws (9). Continue by using the 5/16" nuts, lock washers and flat washer (3) previously removed over clamp (2) and onto screws (9) snug down only at this time.
- 7- Refer to page 5 **Step 1** while working on the driver side place safety plate (4) onto "Quick Release" saddle (1) as shown then refer to page 4 Fig. 2 and assemble the 3/8-16 carriage bolt (6) through safety plate (4) then through "Quick Release" saddle (1). Place the 3/8 hard washer, lock washer and finally hand knob (5) in place and tighten but not fully.
- 8- Refer to page 5 **Step 1** place Safety pin (7) towards the front side of the light bar over the lower cross bar (8c) as shown to prevent any potential interference. Continue now to the passenger side and attach the passenger "Quick Release" saddle in the same manner.
- 9- Refer to page 6 Fig. 5 and with the help of another person gently lower the roof rack so that plates (16) of the roof rack rest into the saddle hooks (1a) of the "Quick Release" saddle (1) both passenger and driver sides.

GOBI JEEP JK WRANGLER ROOF RACK QUICK RELEASE INSTALLATION INSTRUCTIONS

The rack must be inspected before each use to make certain attachments are secure, and for evidence of Wear. Misuse of the rack or failure to observe the manufacturer's instructions as to installation, proper Attachment and maintenance will void any warranties that may be implied by law.

INSTALLATION INSTRUCTIONS:

- 10- Refer to page 5 **Step 2** guide the two round bolt holes (10) in plate (16) of the roof rack over and onto the bolt heads (9) of the "Quick Release" saddle (1) as shown in **Step 2**. While holding the roof rack in place over bolt heads (9) fully loosen the hand knob (5) *not shown* holding safety plate (4) in place then lift and swing safety plate (4) horizontally as shown in **Step 2** and **Step 3** in the direction of letters B,C and D. Continue as shown in **Step 4** by sliding safety plate (4) horizontally under roof rack tubing (11 a) and over roof rack tubing (11 b) finally aligning safety pin holes (4a) of the safety plate (4) and "Quick Release" saddle (1). Fully tighten hand knob (5) as shown on page 4 Fig 2 then apply the same procedure to the opposite side.
- 11- Refer to page 5 **Step 4** and thread safety pin (7) through the aligned holes (4a) of both the Safety plate (4) and "Quick Release" saddle (1) then place spring over the top of the safety pin to prevent release.
- 12- Refer to page 4 Fig 2 while the roof rack is held in place by the "Quick Release" saddles (1), Safety plates (4) and hand knobs (5) fully tighten nuts (3) **"DO NOT BEAR DOWN WITH ALL YOUR MIGHT"** use only enough force to flatten lock washers and apply some tension. Double check that both hand knobs (5) are fully tightened.
- 13- Refer to page 7 Fig 6 tighten both driver and passenger side anti-sway isolator bolts back in place against the triangular wear plates. While tightening pull out slightly on the rear support bar "C" to cause a good tight grip of the rubber tipped isolator bolt onto the wear plates this will prevent the need to use tools to tighten the 5/16" jam nut, Installation Complete. Remove safety tether (14) page 6 Fig. 4 from roof rack and light bar then fold up and stow in glove box for use at a later date. Your roof rack "Quick Release" can now be used tool free to pull back as often as needed the roof rack for Soft top retraction.

"CAUTION"

Roof rack must not be released /pulled back when cargo is present on roof rack or persons are seated within the vehicle. Remove all cargo and vehicle occupants prior to roof rack retraction and reattachment. Always use two persons when using the "Quick Release" system to aid in the release and reattachment process of the roof rack.