

2015

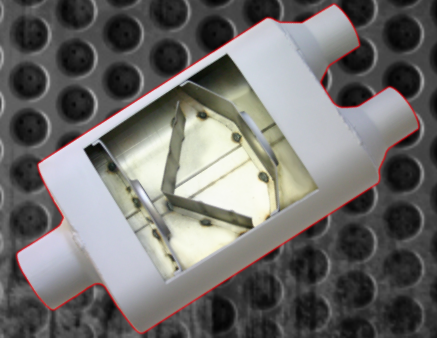
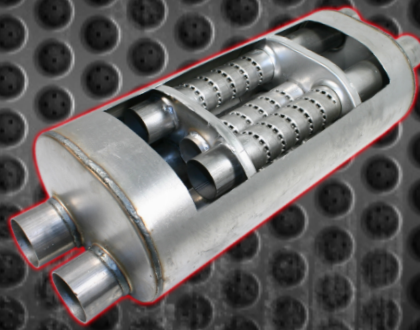
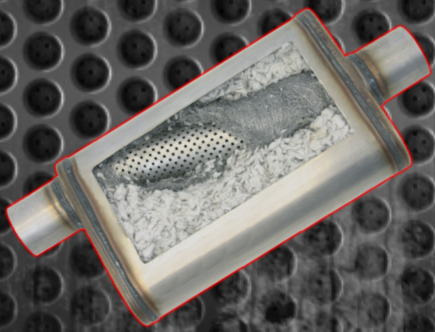

MUFFLERS & ACCESSORIES

FLO~PRO

PERFORMANCE EXHAUST

We're all about options at **FLO~PRO**

Not all mufflers, vehicles and customers are created equal. Our selection of direct and universal fit mufflers offer a wide variety of sound and performance gains that will be sure to satisfy even the most particular customers. Here is a quick look at your options from FLO~PRO.

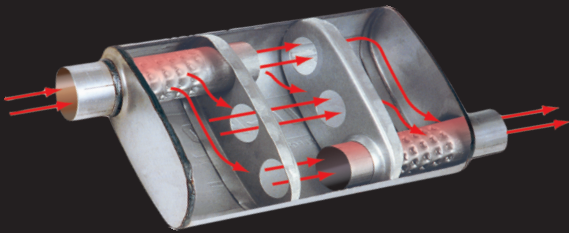

Original FLO~PRO's offer great sound and performance. It offers a deep performance sound with minimal interior resonance. Performance without punishment helps explain these attributes best. Aluminized construction and available in 4 1/4" X 9 3/4" when ground clearance is an issue and 4 3/4" X 11" for big block applications and mellower tone.



The Stainless Steel MAX muffler offers the best flow possible with a straight through perforated flow tube. An excellent deep sound quality that only a packed muffler can offer. The MAX lives up to its name in performance, sound and quality.

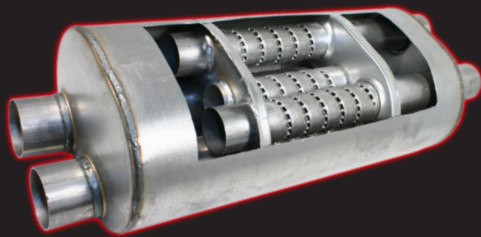

We don't call this FLO~PRO the 2500HD Big Oval for nothing. 9" X 12" body size offers the best in performance and sound qualities available for large gas and diesel engines. Great performance with the least interior resonance is the key to its success especially on Big Block engines. The only true dual outlet muffler available for 4" diesel duals gives you the best performance and sound from your diesel pickup.



Heavy Duty Truck Mufflers are made of 100% Aluminized Steel all welded construction. Available in 6", 7" & 8" Round body sizes and inlet and outlet from 2" - 5". Can be installed on a variety of cars, pickups, and medium duty applications.

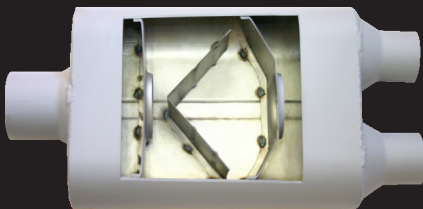

Super V mufflers offer that aggressive V baffle style sound so popular with the younger generation. 100% aluminized all welded construction is sure to give many years of worry free performance for the sport enthusiast. Originally designed for muscle car enthusiasts, but excellent for Pickup, SUV's and anyone looking for a more aggressive sound.

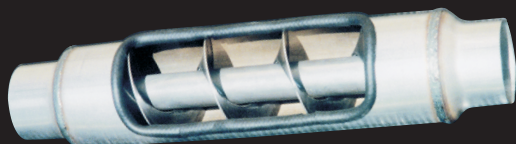

TWISTER Race mufflers blow away the competition with its continuous spiral design for minimal back pressure and horse power loss vs open headers. It's the race muffler that fits in tight places and reduces noise to meet most track requirements. Available in 2 1/4" - 5" inlets also works great for a resonator on noisy diesel applications.

TABLE OF CONTENTS

ORIGINALS

4 1/4" X 9 3/4" OVALS	5-6
4 3/4" X 10 3/4" OVALS	7-8
MX SERIES	9
HEAVY DUTY	10-12
DIESEL POWER	13
HD BIG OVAL 9" X 12"	14-15
FLO~PRO MAX	16-20
SUPER V	21-24

BOTTLED MUFFLERS

TWISTER	25-26
BAFFLE PACKS	27
GLASS PACKS	28-30

ACCESSORIES

X & Y PIPES.....	30
HEADER COLLECTORS	30
MANDREL BENT ELBOWS	31-33
LAP JOINT CLAMPS	33
DIRECT FITTED FLEX	34-35
BRAIDED FLEX	36
HANGERS	37
FORD ECO-BOOST	39

The Only Packing in this Baby... is The Punch!

FLO~PRO has proven it beats the competition with louvered pipe that accelerates the exhaust flow through our muffler. The louvers also give a deep performance sound without the use of fiberglass that eventually blows out!

FLO~PRO performance mufflers are designed to boost the horsepower generated from your street vehicle.

The 100% Aluminized steel welded construction will outlast conventional locked-seam, double wrap mufflers.

The Answer is Obvious...

FLO~PRO increases horsepower, adds fuel economy and is constructed to give you years of worry-free performance.

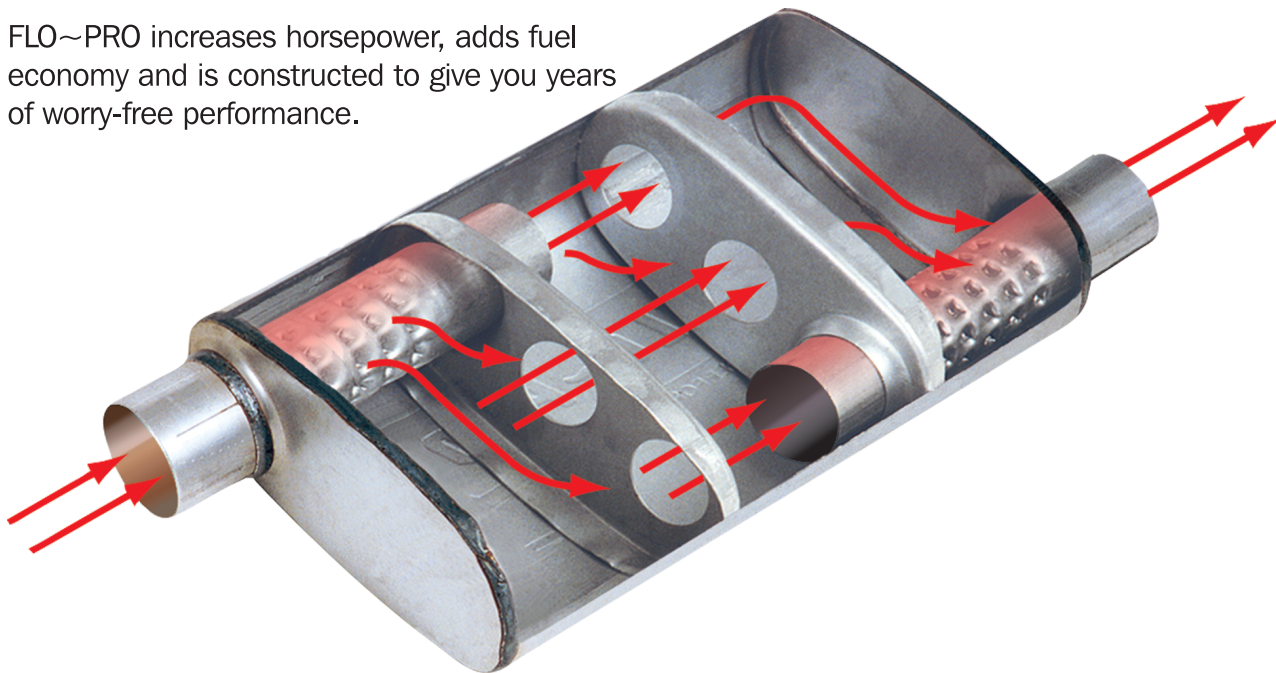

FLO~PRO

PERFORMANCE MUFFLERS

ORIGINALS

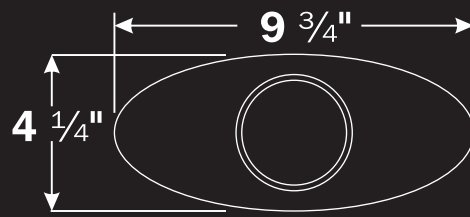

OFFSET / CENTER

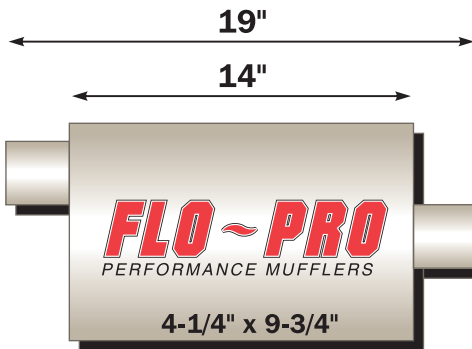

Reversible

Inlet	Outlet	Part #
2"	2"	FP200
2-1/4"	2-1/4"	FP214
2-1/2"	2-1/2"	FP212
3"	3"	FP300

OFFSET / OFFSET

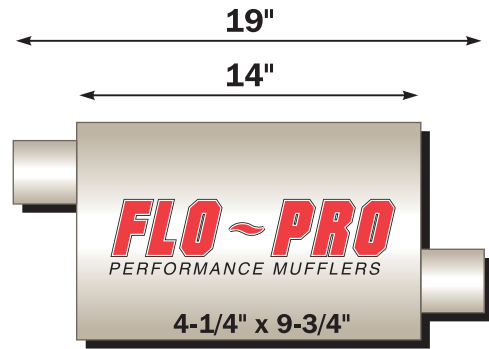

Reversible

Inlet	Outlet	Part #
2"	2"	FP201
2-1/4"	2-1/4"	FP215
2-1/2"	2-1/2"	FP211
3"	3"	FP301

OFFSET / CENTER

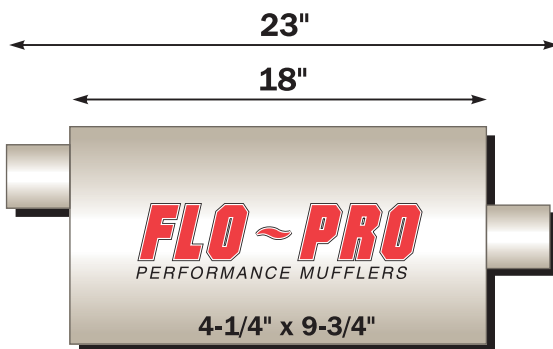

Reversible

Inlet	Outlet	Part #
2-1/4"	2-1/4"	FP765
2-1/2"	2-1/2"	FP760
3"	3"	FP757

OFFSET / OFFSET

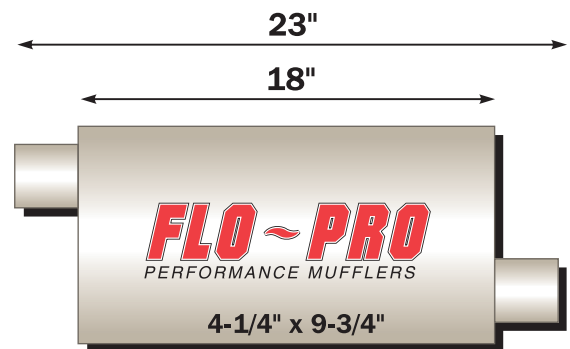

Reversible

Inlet	Outlet	Part #
2-1/4"	2-1/4"	FP774
2-1/2"	2-1/2"	FP775

ORIGINALS

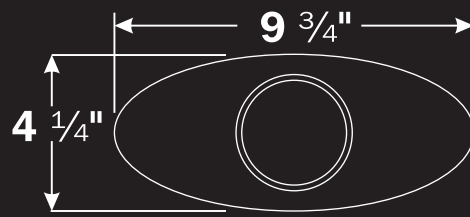

CENTER / DUALS

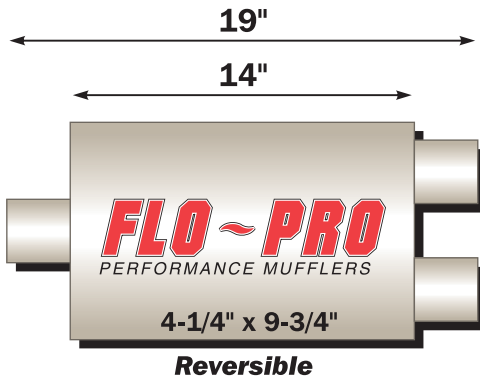

Inlet	Outlet	Part #
2-1/4"	2-1/4"	FP223

CAMARO DUAL OUTLET

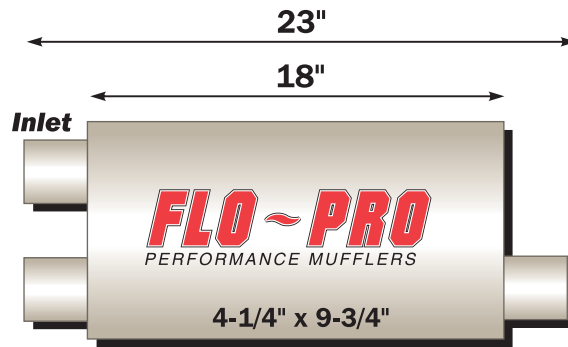

Inlet	Outlet	Part #
2-1/4"	2-1/4"	FP759
2-1/2"	2-1/4"	FP767
3"	2-1/2"	FP768

BUICK GRAND NATIONAL

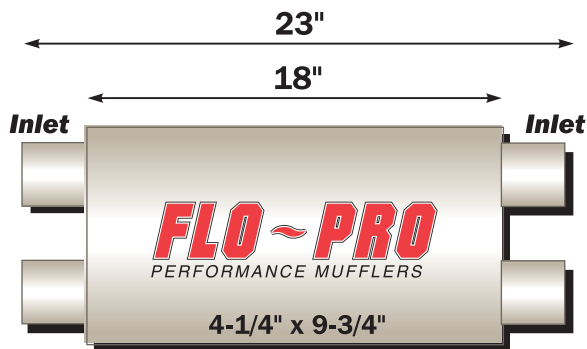

Inlet	Outlet	Part #
2-1/4"	2-1/4"	FP761

FLO~PRO
PERFORMANCE MUFFLERS

ORIGINALS

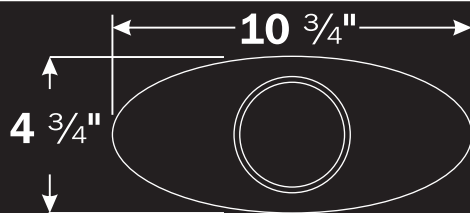

DIESEL MUFFLER

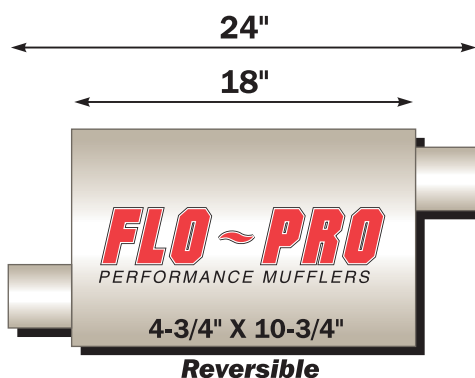

Inlet	Outlet	Part #
3-1/2"	3-1/2"	FP729

**UNIVERSAL REPLACEMENT
99-05 FORD 7.3L
01-05 GM DURAMAX**

OFFSET / CENTER

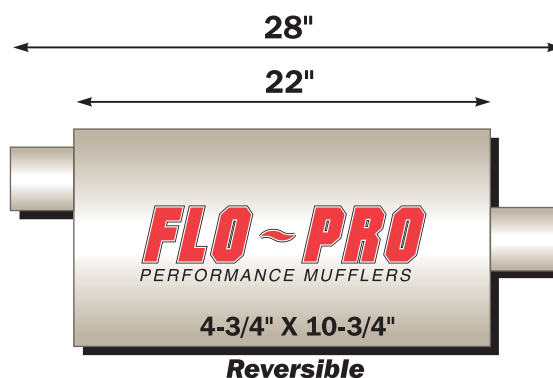

Inlet	Outlet	Part #
2-1/4"	2-1/4"	FP754
2-1/2"	2-1/2"	FP551
3"	3"	FP747
3"	3"	FP710*

* FP710 HAS BEEN SPECIFICALLY DESIGNED FOR FORD V10 MODELS.

CENTER / OFFSET

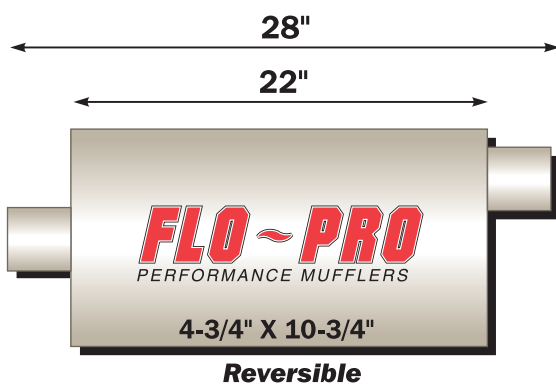

Inlet	Outlet	Part #
3"	3"	FP747
3"	3"	FP746*

* FP746 HAS BEEN REDESIGNED FROM THE FP747, FOR REDUCED NOISE LEVELS CLOSER TO STOCK SOUND.

OFFSET / OFFSET

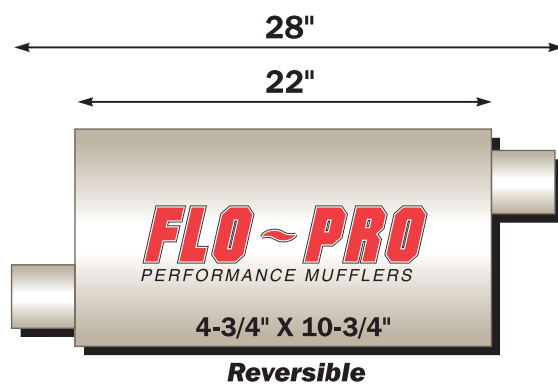

Inlet	Outlet	Part #
2-3/4"	2-3/4"	FP730
3"	3"	FP732

ORIGINALS

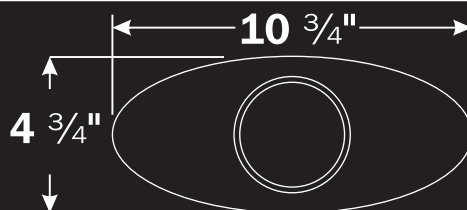

CENTER / DUAL

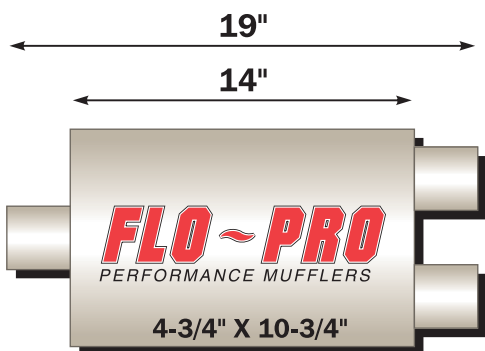

Reversible

Inlet	Outlet	Part #
2-1/2"	2"	FP738
2-1/2"	2-1/4"	FP737
2-1/2"	2-1/2"	FP727
3"	2-1/4"	FP740
3"	2-1/2"	FP739

CENTER / DUAL

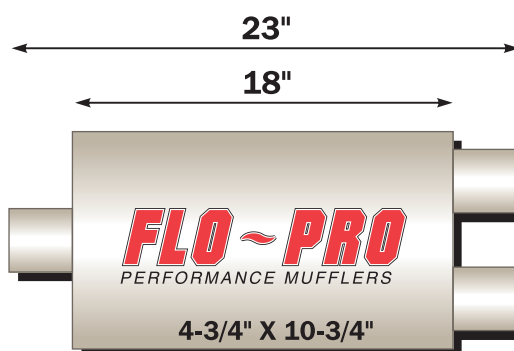

Reversible

Inlet	Outlet	Part #
2-1/2"	2-1/2"	FP736
3"	2-1/4"	FP741

CENTER / DUAL

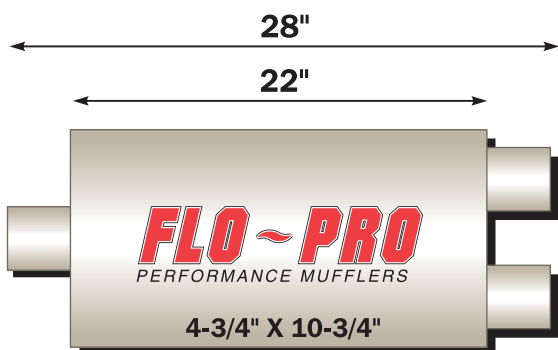

Reversible

Inlet	Outlet	Part #
3"	2-1/4"	FP744
3"	2-1/4"	FP745*
3"	2-1/2"	FP731
3"	3"	FP733

DUAL / DUAL

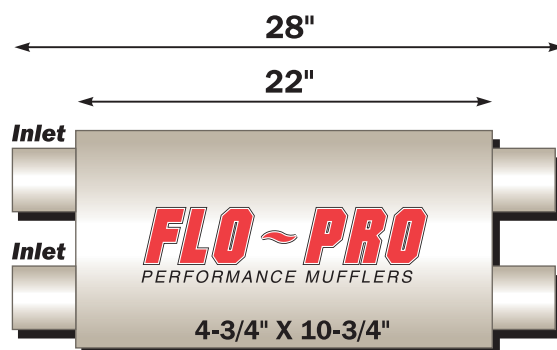

Inlet	Outlet	Part #
2"	2"	FP735
2 1/4"	2 1/4"	FP726

* FP745 HAS BEEN REDESIGNED FROM THE FP744 FOR REDUCED NOISE LEVELS CLOSER TO STOCK SOUND.

ORIGINALS - MX SERIES

REVERSIBLE

OFFSET / CENTER

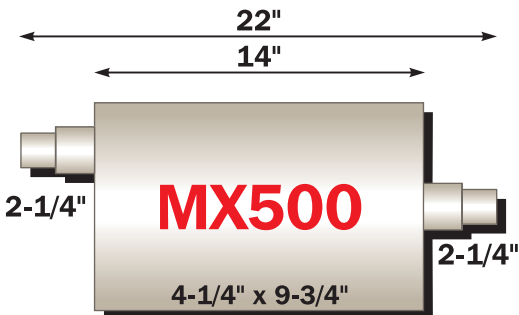

OFFSET / OFFSET

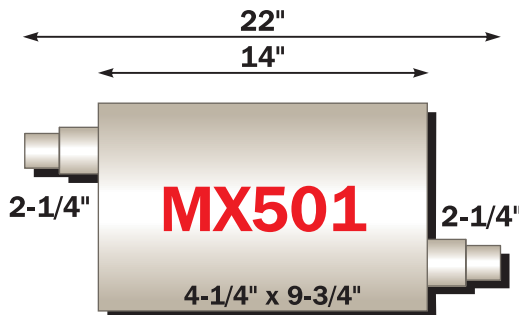

OFFSET / CENTER

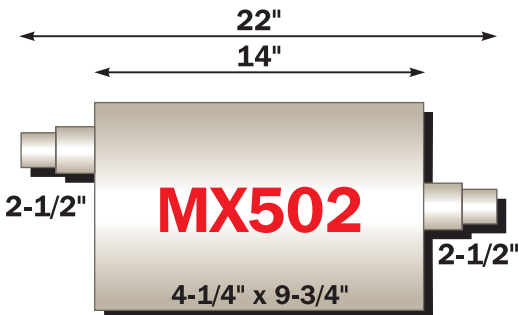

CHEV / GM PICKUP

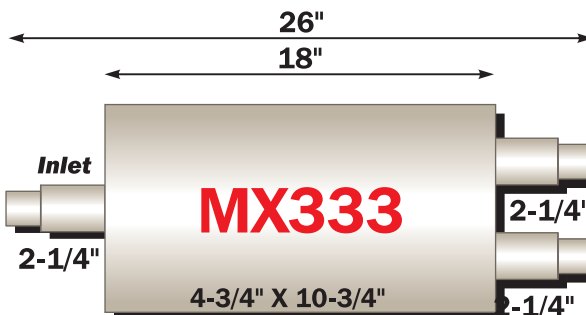

CHEV / GM PICKUP

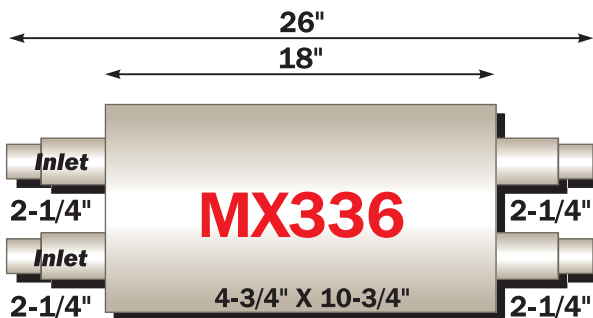

CAMARO

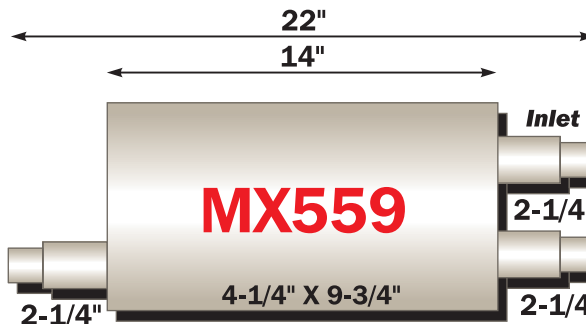

3" FLOW TUBES

HEAVY DUTY

- **Cars, Light Truck & Medium Duty Trucks**
- **All Welded Construction**
- **100% Aluminized**

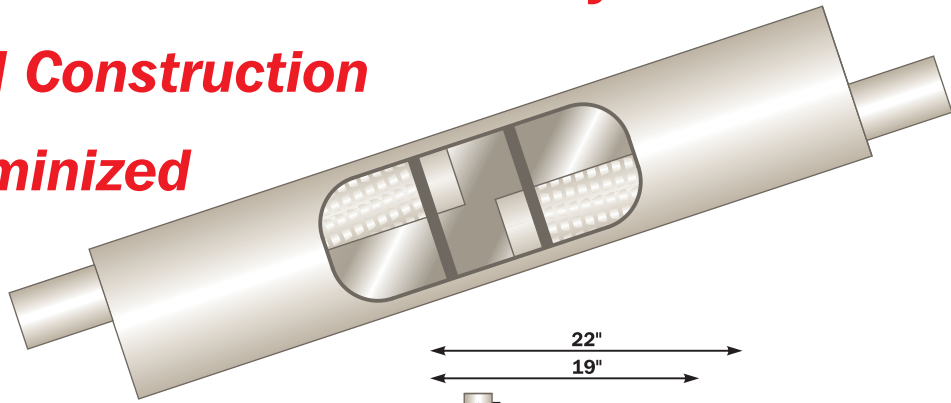

ONAN GENERATOR

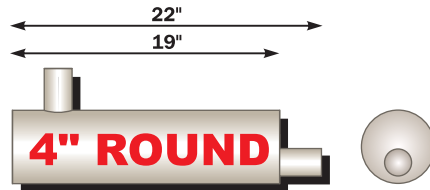

Inlet	Outlet	Part #
1-1/2"	1-1/2"	1953

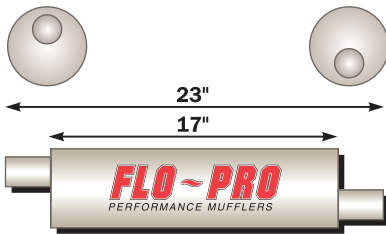

Inlet	Outlet	Part #
1-3/4"	1-3/4"	1009
2"	2"	1010

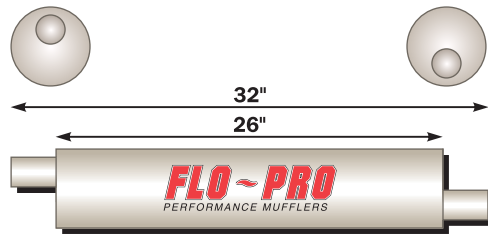

Inlet	Outlet	Part #
2"	2"	1011
2-1/4"	2-1/4"	1012
2-1/2"	2-1/4"	1013
2-1/2"	2-1/2"	4010

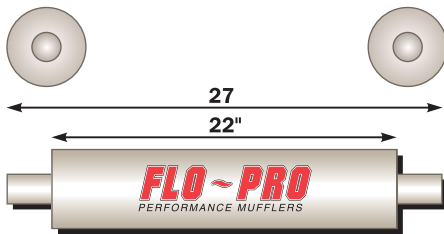

Inlet	Outlet	Part #
2-1/2"	2-1/2"	1016

HEAVY DUTY

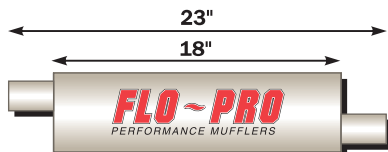

Inlet	Outlet	Part #
2-1/4"	2-1/4"	2000

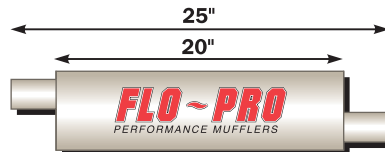

Inlet	Outlet	Part #
3"	3"	3020

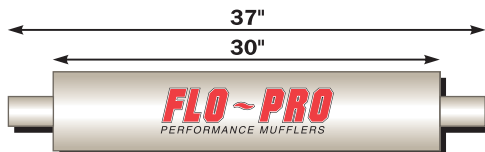

Inlet	Outlet	Part #
3"	3"	4126

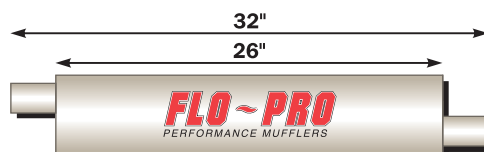

Inlet	Outlet	Part #
2-1/4"	2-1/4"	4014
2-1/2"	2-1/4"	4011
2-1/2"	2-1/2"	4013
3"	3"	4115

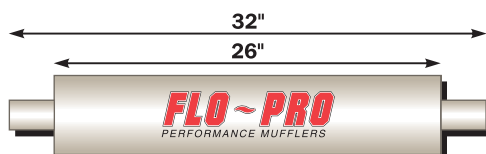

Inlet	Outlet	Part #
3"	3"	4025

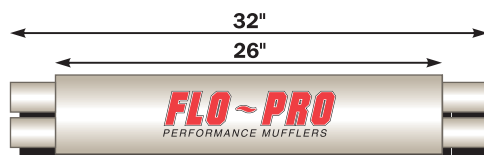

Inlet	Outlet	Part #
2-1/4"	2-1/4"	4020
2-1/2"	2-1/2"	4017

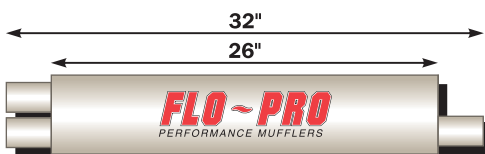

Inlet	Outlet	Part #
2-1/4"	2-1/4"	4021
2-1/2"	2-1/2"	4122

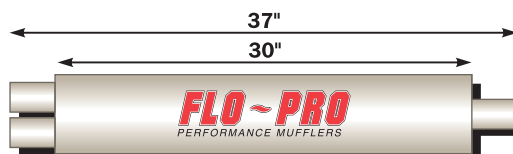

Inlet	Outlet	Part #
2-1/2"	3"	4027

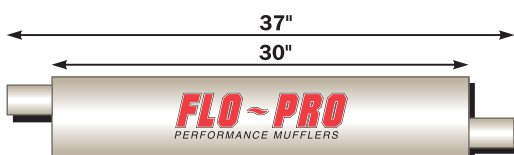

Inlet	Outlet	Part #
3"	3"	4114

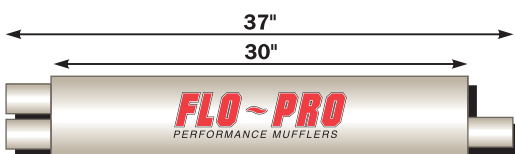

Inlet	Outlet	Part #
2-1/2"	2-1/2"	4123

94-95 CHEV/GMC PICKUP

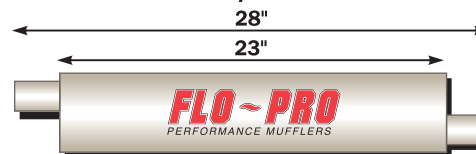

Inlet	Outlet	Part #
2-3/4"	2-3/4"	3019

HEAVY DUTY

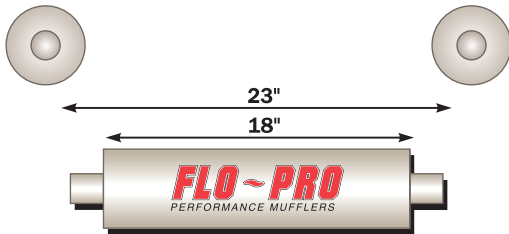

Inlet	Outlet	Part #
3-1/2"	4"	8890

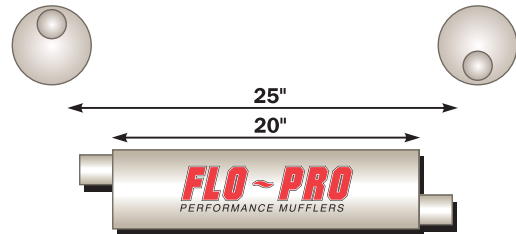

Inlet	Outlet	Part #
3"	3"	1976

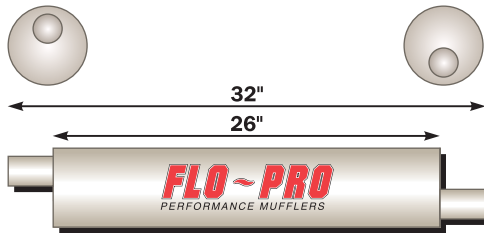

Inlet	Outlet	Part #
2-1/2"	2-1/2"	1978
4"	3"	8972
4"	4"	8992

8972 FITS 1994-02 DODGE CUMMINS

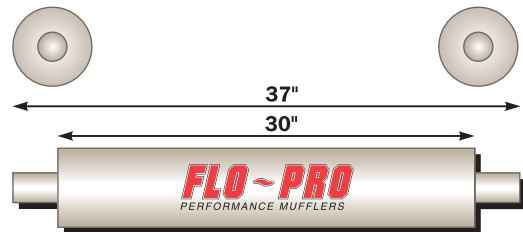

Inlet	Outlet	Part #
3"	3"	1974
3-1/2"	3-1/2"	8880
4"	4"	8990

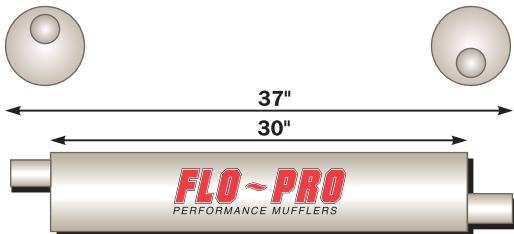

Inlet	Outlet	Part #
3"	3"	1972

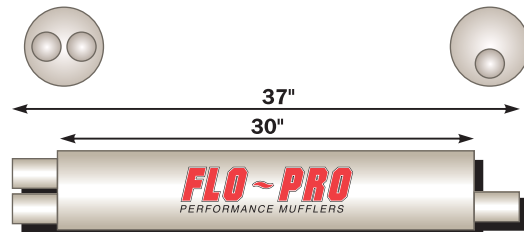

Inlet	Outlet	Part #
2-1/2"	3"	1975

DIESEL POWER



ALUMINIZED

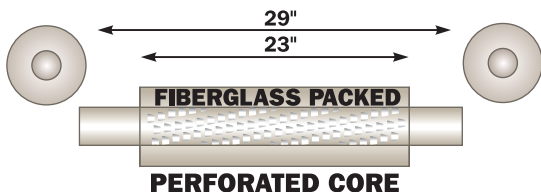

Inlet	Outlet	Part #
4"	4"	6195
5"	5"	6196

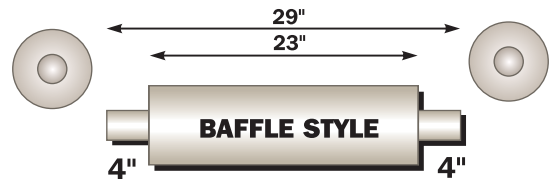

Inlet	Outlet	Part #
4"	4"	6192

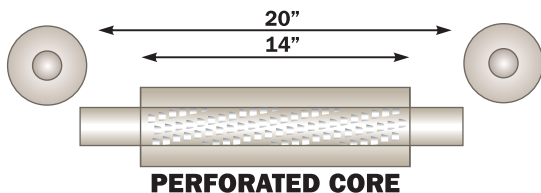

Inlet	Outlet	Part #
4"	4"	6185
5"	5"	6186

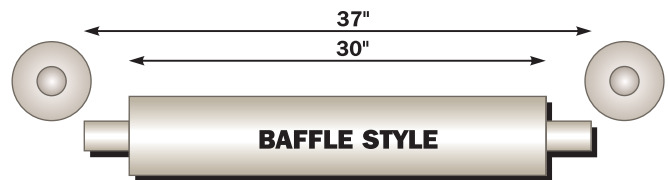

Inlet	Outlet	Part #
3-1/2"	3-1/2"	8880
4"	4"	8990

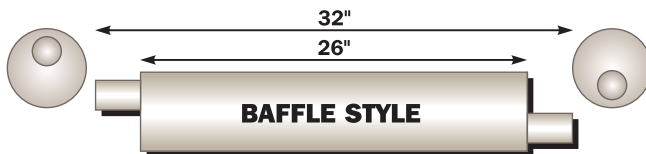

Inlet	Outlet	Part #
4"	3"	8972
4"	4"	8992

8972 FITS 1994-02 DODGE CUMMINS

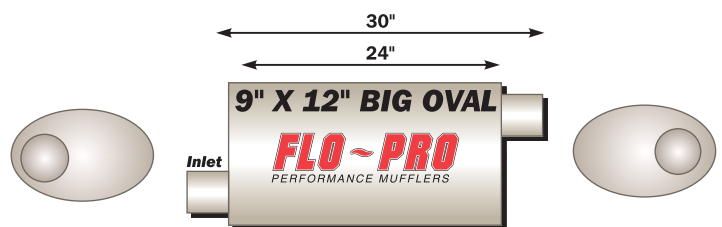

Inlet	Outlet	Part #
4"	4"	2507

STAINLESS STEEL

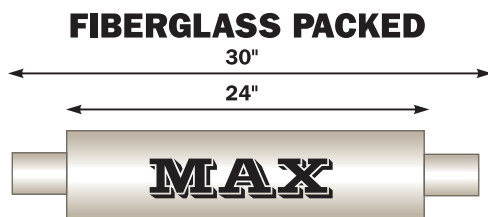

Inlet	Outlet	Part #
4"	4"	M12772
5"	5"	M12774

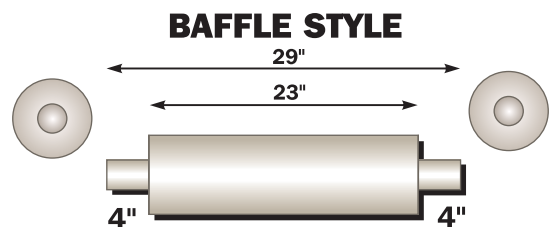

Inlet	Outlet	Part #
4"	4"	7192

HD BIG OVAL

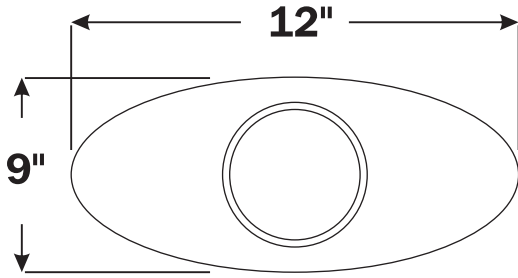
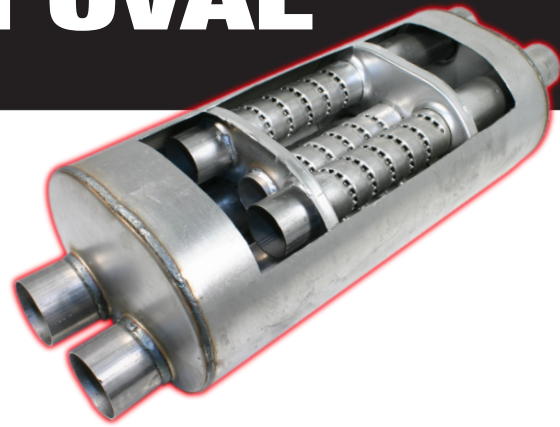

CENTER / OFFSET

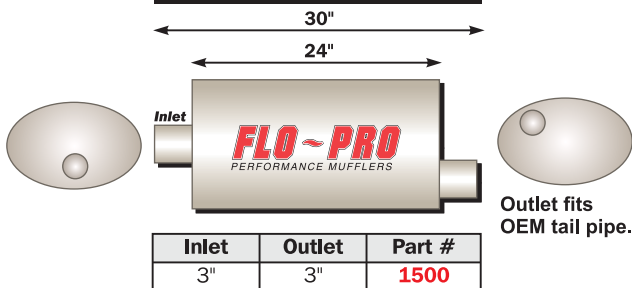

DIRECT FIT GM "Classic 1500" 4.8L & 5.3L Engines
Stock Sound

DUAL / DUAL

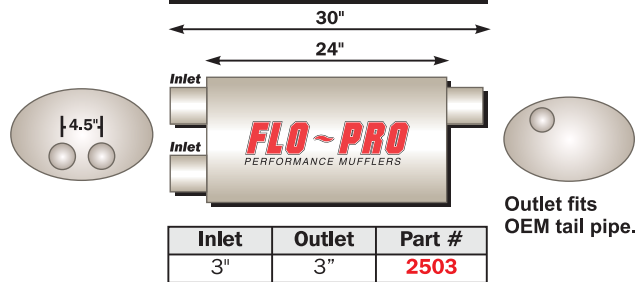

DIRECT FIT GM "Classic 1500 HD" 6.0L Engines
Stock Sound

DUAL / DUAL

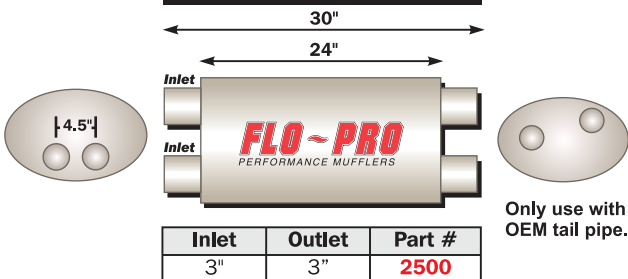

DIRECT FIT GM "Classic 2500HD" 6.0L Engines
Stock Sound

** Use only with factory tailpipe **

OFFSET / OFFSET

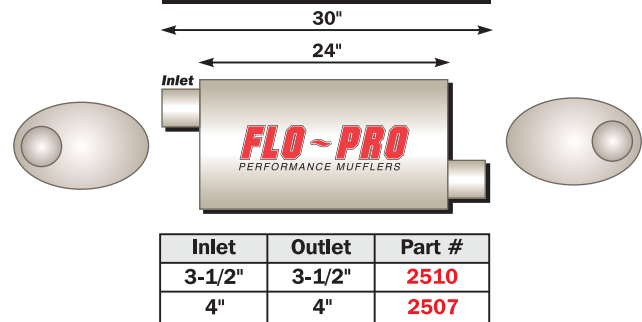

2510 DIRECT FIT GM "07NBS 2500 HD" 6.0L & 6.2L Engines
Moderate Sound Increase from Stock

CENTER / OFFSET

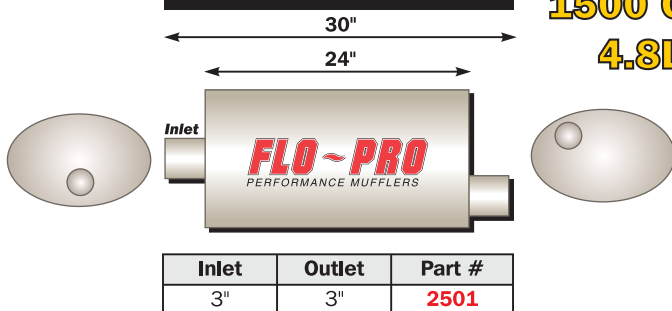

1500 GM Pick Up
4.8L & 5.3L

Use with universal 3" tail pipe

CENTER / DUAL

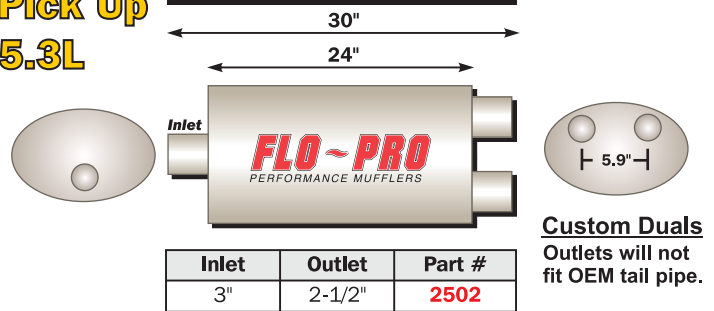

Can be used with most
aftermarket 2 1/2" dual tail pipes

HD BIG OVAL

DUAL / DUAL

30"
24"

Custom Duals
Outlets will not fit OEM tail pipe.

Inlet	Outlet	Part #
3"	2-1/2"	2504

CUSTOM DUALS

Can be used with most aftermarket 2 1/2" dual tail pipes

DUAL / DUAL

30"
24"

Custom Duals
Outlets fit OEM tail pipe.

Inlet	Outlet	Part #
3"	3"	2505
3"	3"	2506*

*Use only with factory tailpipe

DIRECT FIT GM Classic "HD", 6.0L & 8.1L Engines

OFFSET / DUAL

30"
24"

Custom Duals
Outlets will not fit OEM tail pipe.

Inlet	Outlet	Part #
3-1/2"	2-1/2"	2508

OFFSET / DUAL

30"
24"

Custom Duals
Outlets will not fit OEM tail pipe.

Inlet	Outlet	Part #
3-1/2"	3"	2509

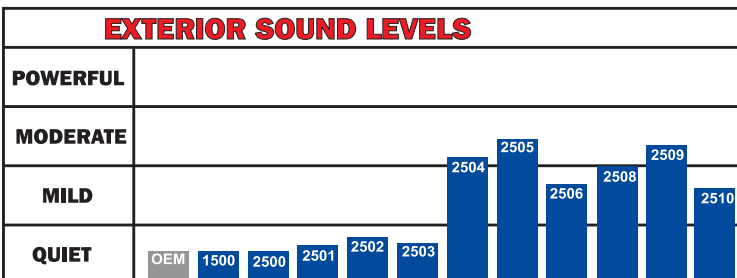
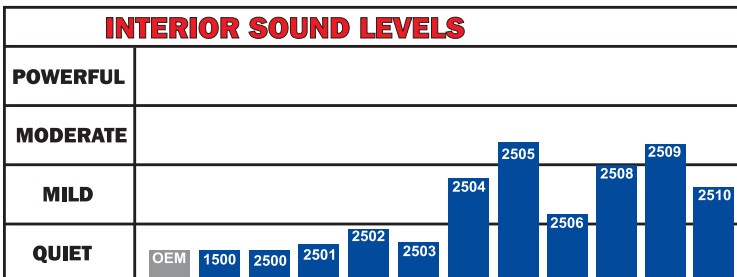

DODGE 5.7L HEMI

30"
24"

Will Fit OEM Duals
All others require custom duals.

Inlet	Outlet	Part #
3"	2-1/4"	2511

NEW Outlet Length 12"

Bolt On ST10970B

Rolled Side Exit

IN 3-1/2" OUT 4"

FLO~PRO

MAX

www.flopro.com

Increased number of smaller holes eliminates blowout and maintains a deep toned performance sound.

Large diameter mandrel bent one-piece stainless steel core. Straight through for low restriction.

Heavy gauge stainless steel construction.

Stainless Steel

Reversible

Densely packed with high temp sound absorbing material resists meltdown, matting and blowout.

Thick stainless steel mesh adds additional sound absorption and prevents against blowout.

All welded seams and joints for toughness and durability.

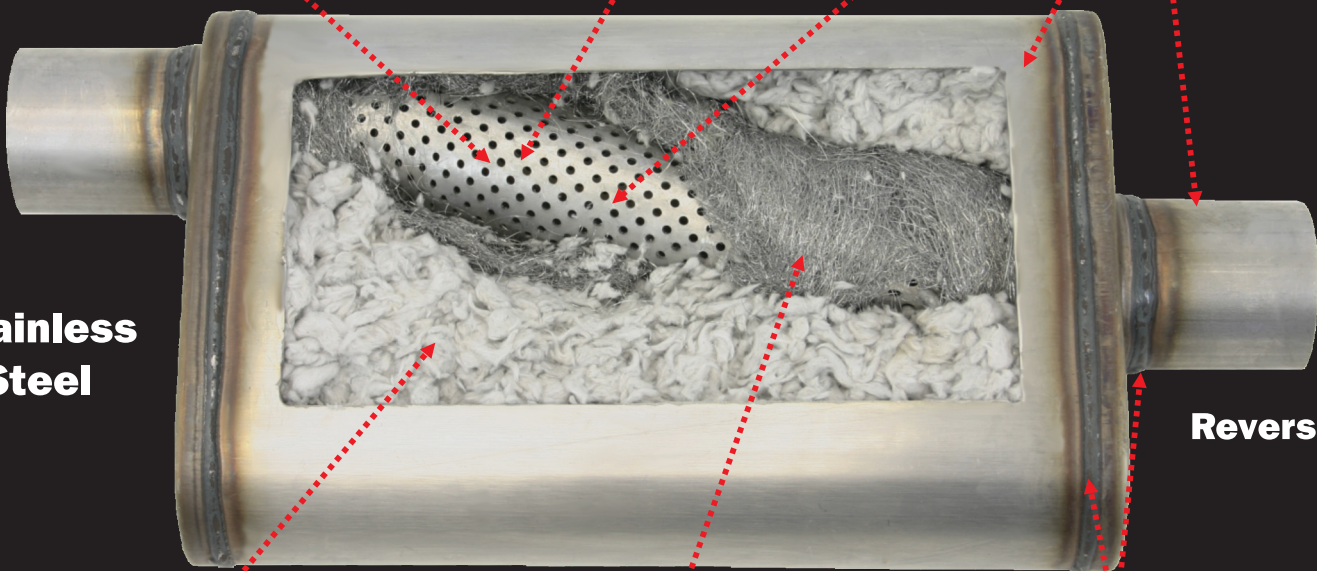

MAX SERIES

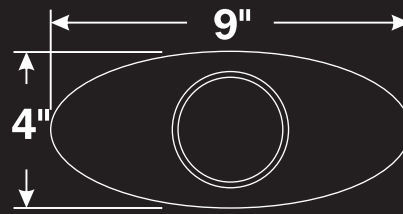

OFFSET / CENTER

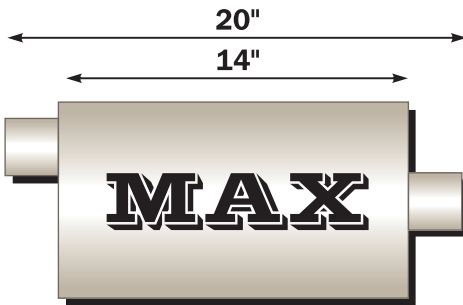

Reversible

Inlet	Outlet	Part #
2"	2"	M11224
2-1/4"	2-1/4"	M11225
2-1/2"	2-1/2"	M11226
3"	3"	M11229

OFFSET / OFFSET

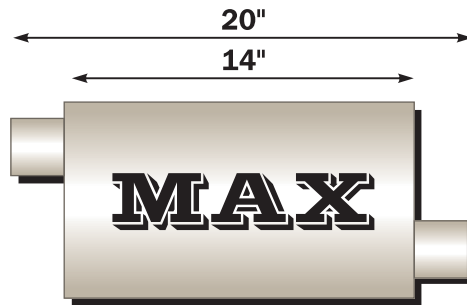

Reversible

Inlet	Outlet	Part #
2"	2"	M11234
2-1/4"	2-1/4"	M11235
2-1/2"	2-1/2"	M11236
3"	3"	M11239

OFFSET / CENTER

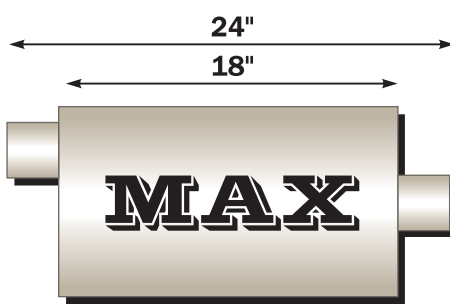

Reversible

Inlet	Outlet	Part #
2-1/4"	2-1/4"	M11255
2-1/2"	2-1/2"	M11256
3"	3"	M11259

OFFSET / OFFSET

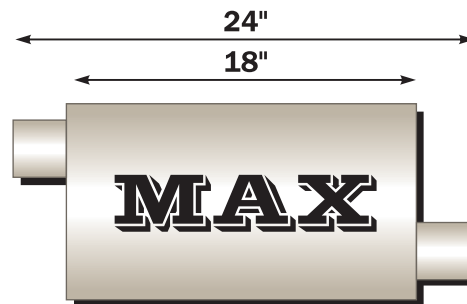

Reversible

Inlet	Outlet	Part #
2-1/4"	2-1/4"	M11265
2-1/2"	2-1/2"	M11266

MAX SERIES

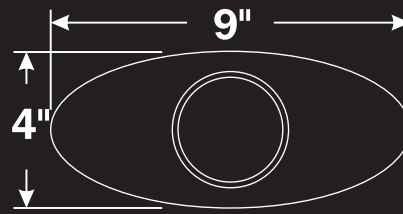

CENTER / DUAL

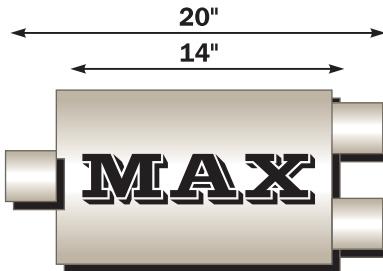

Reversible

Inlet	Outlet	Part #
2-1/4"	2-1/4"	M11149

CENTER / DUAL

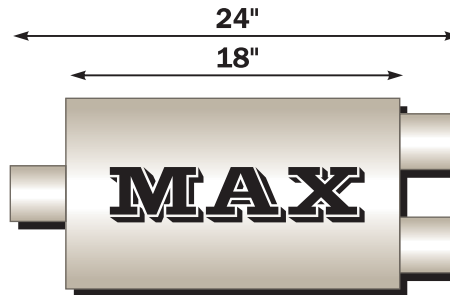

Reversible

Inlet	Outlet	Part #
2-1/2"	2-1/4"	M11258
2-1/2"	2-1/2"	M11268
3"	2-1/4"	M11278
3"	2-1/2"	M11288

OFFSET / CENTER

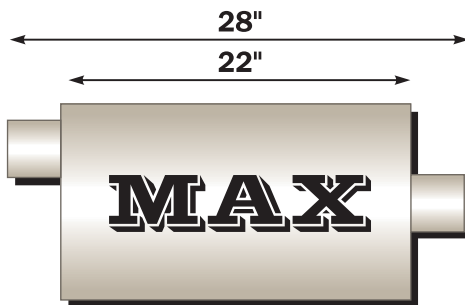

Reversible

Inlet	Outlet	Part #
3"	3"	M11589



MAX SERIES

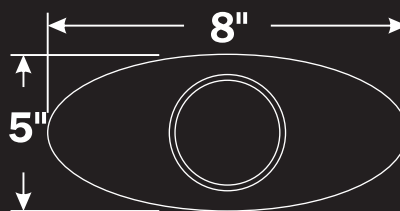

OFFSET / CENTER

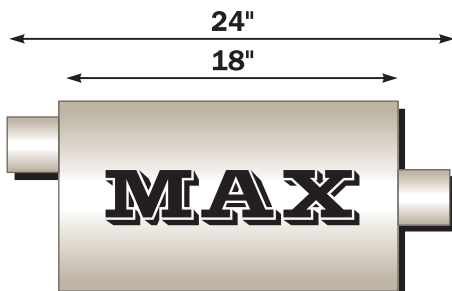

Reversible

Inlet	Outlet	Part #
2-1/4"	2-1/4"	M12255
2-1/2"	2-1/2"	M12256
3"	3"	M12259

OFFSET / CENTER

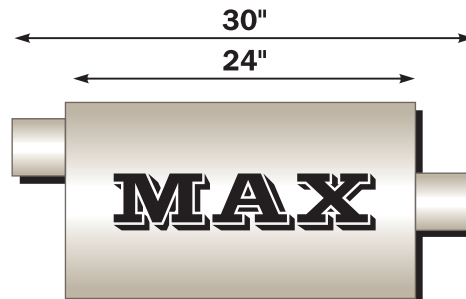

Reversible

Inlet	Outlet	Part #
3"	3"	M12289

CENTER / DUAL

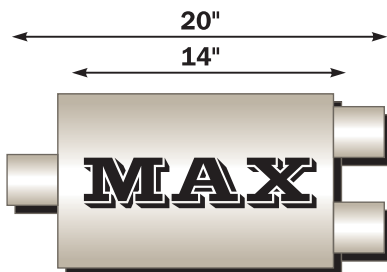

Reversible

Inlet	Outlet	Part #
2-1/4"	2-1/4"	M12149
2-1/2"	2-1/2"	M12158
3"	2-1/2"	M12198

CENTER / DUAL

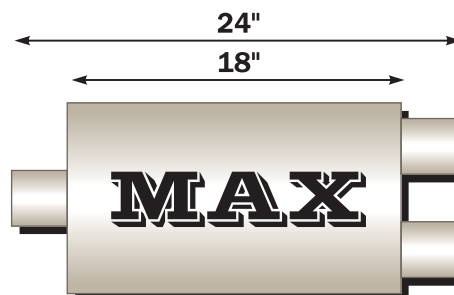

Reversible

Inlet	Outlet	Part #
2-1/2"	2-1/4"	M12258
2-1/2"	2-1/2"	M12268
3"	2-1/4"	M12278
3"	2-1/2"	M12288
3"	3"	M12298

DUAL / DUAL

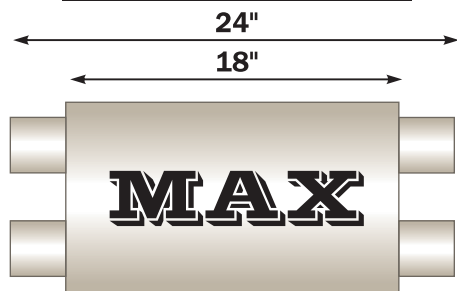

Reversible

Inlet	Outlet	Part #
2-1/2"	2-1/2"	M12468
3"	3"	M12469



MAX SERIES

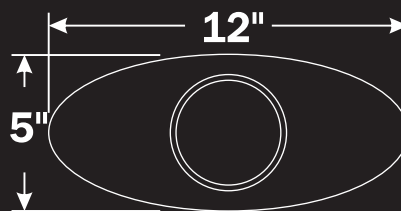

OFFSET / CENTER

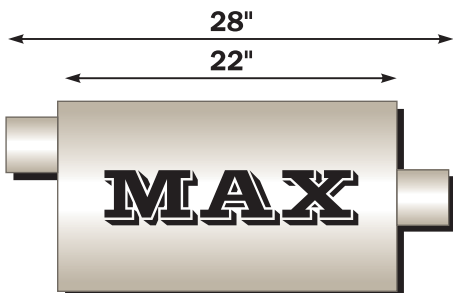

Reversible

Inlet	Outlet	Part #
3"	3"	M12589

CENTER / DUAL

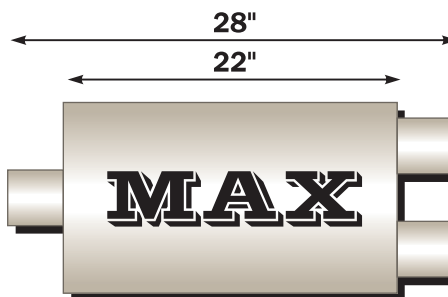

Reversible

Inlet	Outlet	Part #
3"	2-1/4"	M12585
3"	2-1/2"	M12588
3"	3"	M12590

DUAL / DUAL

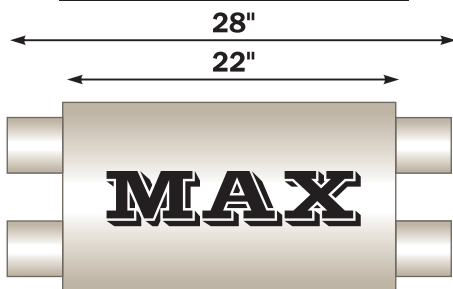

Reversible

Inlet	Outlet	Part #
2-1/4"	2-1/4"	M12567
2-1/2"	2-1/2"	M12568

8" ROUND CENTER / DUAL

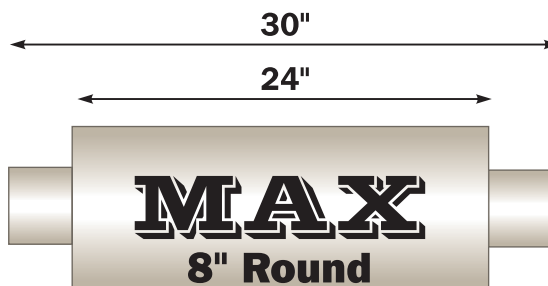

Reversible

Inlet	Outlet	Part #
4"	4"	M12772
5"	5"	M12774

FLO~PRO





Performance Mufflers



**GREAT SOUND
ADDED PERFORMANCE
QUALITY CONSTRUCTION**

***Performance Sound
...at a price you can afford!***

SUPER V

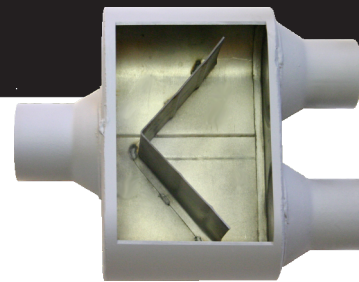

SINGLE CHAMBER

CENTER / CENTER

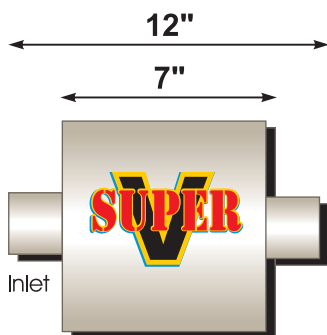

Inlet	Outlet	Part #
2-1/2"	2-1/2"	V425109
3"	3"	V430109

CENTER / DUAL

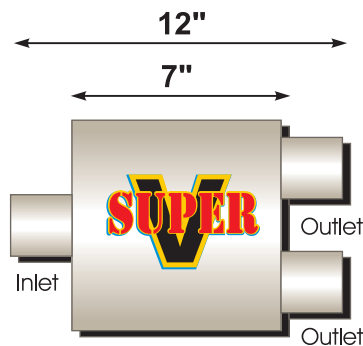

Inlet	Outlet	Part #
2-1/2"	2-1/4"	V425122
3"	2-1/4"	V430122

OFFSET / CENTER

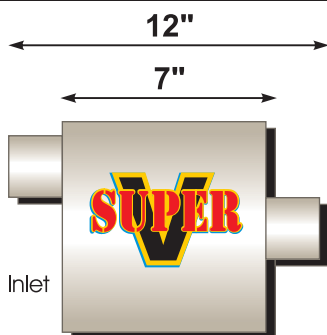

Inlet	Outlet	Part #
2-1/4"	2-1/4"	V72441
2-1/2"	2-1/2"	V72541
3"	3"	V73041

OFFSET / OFFSET

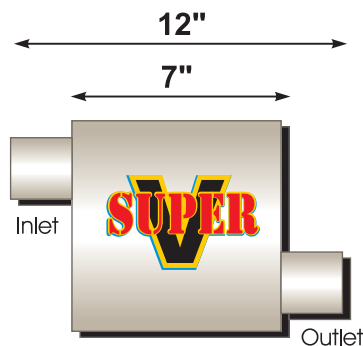

Inlet	Outlet	Part #
2-1/2"	2-1/4"	V72443
2-1/2"	2-1/2"	V72543

SUPER V

TWO CHAMBER

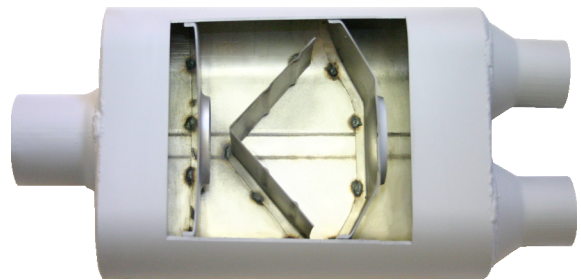

CENTER / CENTER

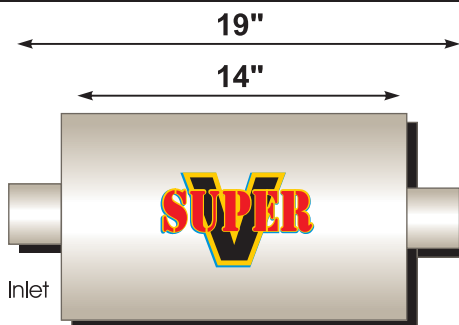

Inlet	Outlet	Part #
2-1/4"	2-1/4"	V42440
3"	3"	V43040

CENTER / OFFSET

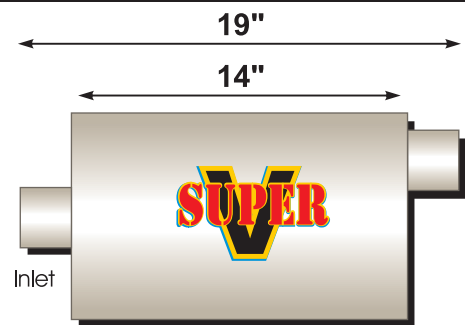

Inlet	Outlet	Part #
2 1/4"	2 1/4"	V42442
3"	3"	V43042

OFFSET / CENTER

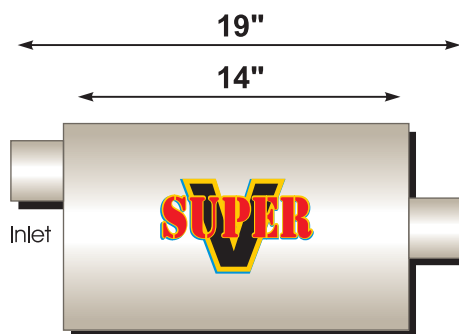

Inlet	Outlet	Part #
2"	2"	V42041
2-1/4"	2-1/4"	V42441
2-1/2"	2-1/2"	V42541
3"	3"	V43041

OFFSET / OFFSET

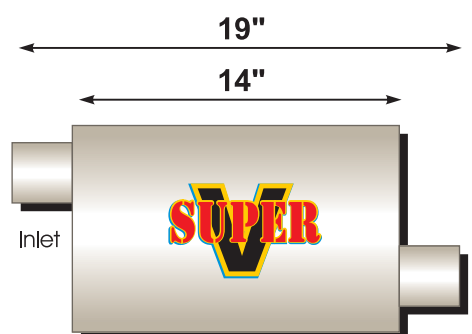

Inlet	Outlet	Part #
2"	2"	V42043
2-1/4"	2-1/4"	V42443
2-1/2"	2-1/2"	V42543
3"	3"	V43043

SUPER V

CENTER / DUAL

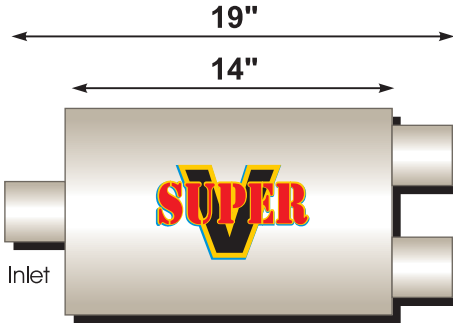

Inlet	Outlet	Part #
2 1/4"	2 1/4"	V424422
2 1/2"	2 1/4"	V425422
2 1/2"	2 1/2"	V425400
3"	2 1/4"	V430422
3"	2 1/2"	V430402

DUAL / DUAL

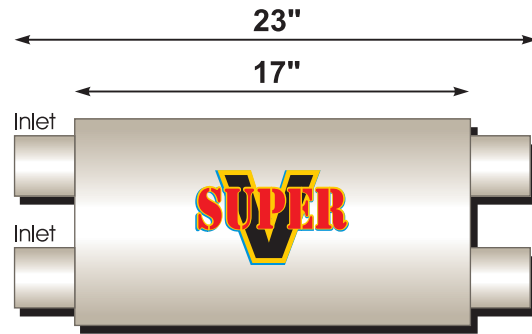

Inlet	Outlet	Part #
2 1/4"	2 1/4"	V524554
2 1/2"	2 1/2"	V525554
3"	3"	V530554

CENTER / OFFSET

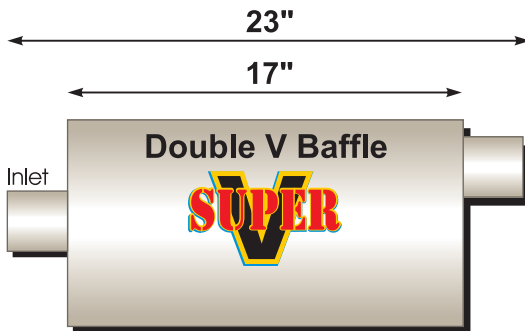

Inlet	Outlet	Part #
3"	3"	V53057

DUAL / CENTER

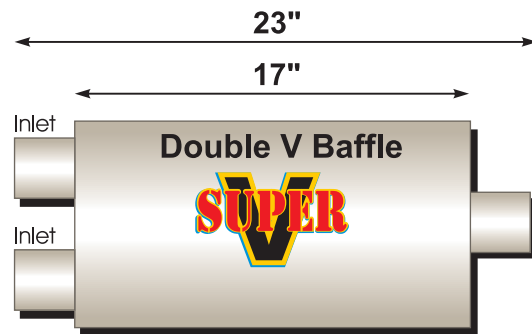

Inlet	Outlet	Part #
2 1/4"	3"	V524553

CAMARO DUAL OUTLET

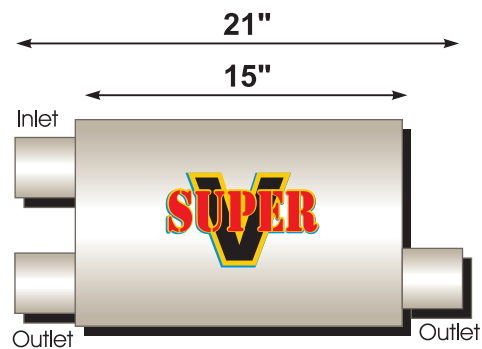

Inlet	Outlet	Part #
2 1/2"	2 1/2"	V42583

The NEW Double V Baffle CENTER/OFFSET & DUAL/CENTER



*Labeled as "Double V Baffle"

TWISTER

RACE MUFFLER

The Race Car Muffler that provides the best performance, noise reduction, fit and affordability

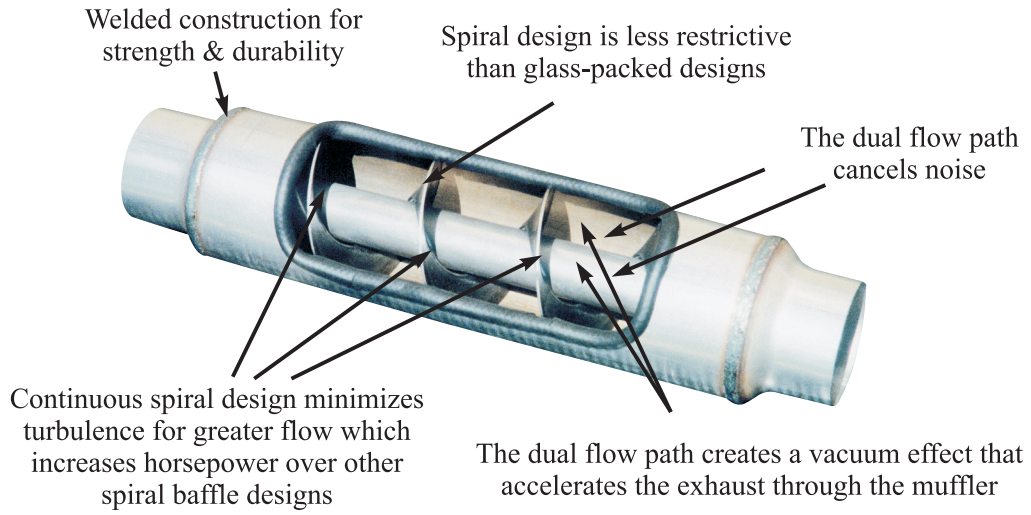

- Race Muffler that fits in tight places
- Reduces noise to meet most track requirements
- Insignificant loss of horsepower from open headers
- Great fit for street-legal high performance cars & trucks

TWISTER F5 SERIES

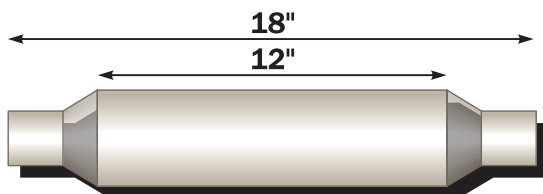

Inlet	Outlet	Part #
3"	3"	51277
3-1/2"	3-1/2"	51288
4"	4"	51299
5"	5"	51600

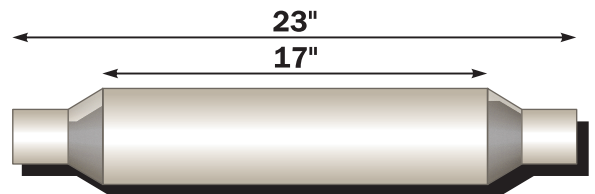

Inlet	Outlet	Part #
3"	3"	51777
3-1/2"	3-1/2"	51788

TWISTER F4 SERIES

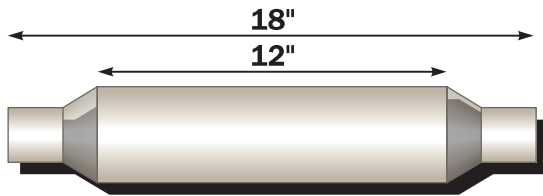

Inlet	Outlet	Part #
2-1/4"	2-1/4"	41244
2-1/2"	2-1/2"	41255
3"	3"	41277
3-1/2"	3-1/2"	41288

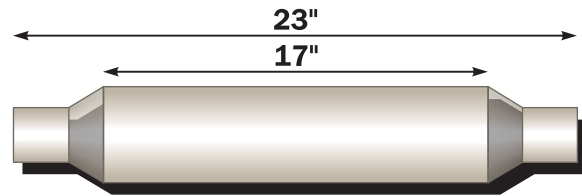

Inlet	Outlet	Part #
2-1/4"	2-1/4"	41744
2-1/2"	2-1/2"	41755
3"	3"	41777

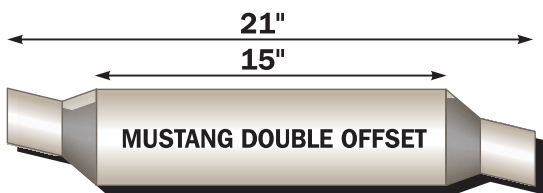

Inlet	Outlet	Part #
2-1/4"	2-1/4"	412244

TWISTER
RACE MUFFLER

BAFFLE PACKS

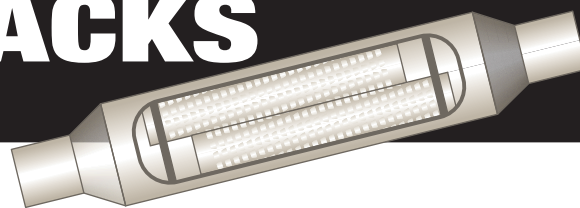

CASE DIAMETER	CASE LENGTH	OVERALL LENGTH	INLET SIZE	OUTLET SIZE	OFFSET	PART NUMBER
3"	10"	16"	1"	1"	STRAIGHT	3303
3"	10"	16"	1-1/2"	1-1/2"	STRAIGHT	3300
3"	10"	16"	1-3/4"	1-3/4"	STRAIGHT	3302
3"	12"	17"	1-1/2"	1-1/2"	STRAIGHT	3301
4"	12"	18"	2"	2"	STRAIGHT	4406
4"	12"	18"	2"	2"	SINGLE	4405
4"	15"	21"	2"	2"	STRAIGHT	4423
4"	17"	23"	2"	2"	STRAIGHT	4415
4"	17"	23"	2-1/4"	2-1/4"	STRAIGHT	4415X
4"	17"	23"	2-1/2"	2-1/2"	STRAIGHT	4415XX
4"	17"	23"	2"	2"	SINGLE	4414
4"	17"	23"	2-1/4"	2-1/4"	SINGLE	4414X
4"	17"	23"	2-1/2"	2-1/2"	SINGLE	4414XX
4"	17"	23"	2"	2"	DOUBLE	4418
4"	17"	23"	2-1/4"	2-1/4"	DOUBLE	4418X
4"	17"	23"	2-1/2"	2-1/2"	DOUBLE	4418XX
4"	20"	26"	2"	2"	STRAIGHT	4420
4"	24"	30"	2"	2"	STRAIGHT	4421
4"	24"	30"	2-1/4"	2-1/4"	STRAIGHT	4422
5"	20"	28"	2-1/2"	2-1/4"	STRAIGHT	5520
5"	22"	29"	3"	3"	STRAIGHT	5522

GLASS PACKS

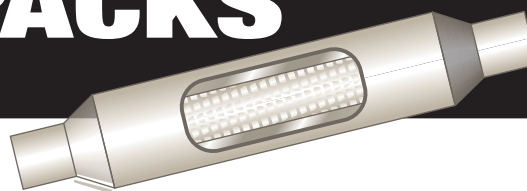

CASE DIAMETER	CASE LENGTH	CORE DIAMETER	OVERALL LENGTH	INLET SIZE	OFFSET	PART NUMBER
3"	10"	1-3/4"	15"	1-3/4"	STRAIGHT	3010STR
3"	10"	2"	15"	2"	STRAIGHT	3010STR2
3"	12"	1-3/4"	12"	BLANK		3012
3"	12"	1-3/4"	17"	1-3/4"	STRAIGHT	3012ST
3"	15"	1-3/4"	15"	BLANK		3015
3"	15"	1-3/4"	20"	1-3/4"	STRAIGHT	3015ST
3"	17"	1-3/4"	17"	BLANK		3018
3"	17"	1-3/4"	22"	1-3/4"	STRAIGHT	3018ST
3-1/2"	9"	2"	9"	BLANK		3509
3-1/2"	9"	2"	14"	2"	STRAIGHT	3509ST
3-1/2"	12"	2"	12"	BLANK		3512
3-1/2"	12"	2"	17"	2"	STRAIGHT	3512ST
3-1/2"	12"	2"	18"	2"	SINGLE	3512S0
3-1/2"	15"	2"	15"	BLANK		3515
3-1/2"	15"	2"	21"	2"	STRAIGHT	3515ST
3-1/2"	15"	2"	20"	2-1/4"	STRAIGHT	3515STX
3-1/2"	17"	2"	17"	BLANK		3518
3-1/2"	17"	2"	22"	2"	STRAIGHT	3518ST
3-1/2"	17"	2"	22"	2-1/4"	STRAIGHT	3518STX
3-1/2"	17"	2"	22"	2-1/2"	STRAIGHT	3518STXX
3-1/2"	17"	2"	23"	2"	SINGLE	3518S0
3-1/2"	17"	2"	23"	2"	DOUBLE	3518D0
3-1/2"	17"	2"	23"	2-1/4"	SINGLE	3518S0X
3-1/2"	20"	2"	25"	2"	STRAIGHT	3520ST
3-1/2"	20"	2"	20"	BLANK		3520
3-1/2"	24"	2"	24"	BLANK		3524
3-1/2"	24"	2"	29"	2"	STRAIGHT	3524ST
3-1/2"	30"	2"	30"	BLANK		3530
3-1/2"	30"	2"	35"	2"	STRAIGHT	3530ST
3-1/2"	36"	2"	36"	BLANK		3536
3-1/2"	36"	2"	41"	2"	STRAIGHT	3536ST
4"	9"	2-1/4"	9"	BLANK		4009
4"	12"	2-1/4"	12"	BLANK		4012
4"	12"	2-1/4"	17"	2-1/4"	STRAIGHT	4012ST
4"	15"	2-1/4"	20"	2-1/4"	STRAIGHT	4015ST
4"	15"	2-1/4"	15"	BLANK		4015

GLASS PACKS

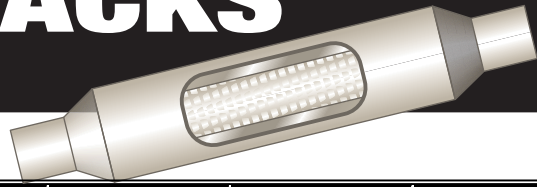

CASE DIAMETER	CASE LENGTH	CORE DIAMETER	OVERALL LENGTH	INLET SIZE	OFFSET	PART NUMBER
4"	17"	2-1/2"	24"	2-1/2"	STRAIGHT	4518ST
4"	17"	2-1/2"	17"	BLANK		4518
4"	17"	2-1/4"	17"	BLANK		4018
4"	17"	2-1/4"	22"	2-1/4"	STRAIGHT	4018ST
4"	17"	2-1/4"	23"	2-1/4"	SINGLE	4018SO
4"	17"	2-1/4"	23"	2-1/4"	DOUBLE	4018DO
4"	17"	3"	24"	3"	STRAIGHT	4318ST
4"	17"	3"	17"	BLANK		4318
4"	24"	2-1/4"	24"	BLANK		4024
4"	24"	2-1/4"	29"	2-1/4"	STRAIGHT	4024ST
4"	30"	2-1/4"	35"	2-1/4"	STRAIGHT	4030ST
4"	30"	2-1/4"	30"	BLANK		4030
4"	36"	2-1/4"	41"	2-1/4"	STRAIGHT	4036ST
5"	17"	3"	24"	2-1/2"	STRAIGHT	5018ST
5"	17"	3"	24"	3"	STRAIGHT	5318ST
5"	30"	3"	37"	3"	STRAIGHT	5330ST

POWER PACKS



CASE DIAMETER	CASE LENGTH	CORE DIAMETER	OVERALL LENGTH	INLET SIZE	OUTLET SIZE	PART NUMBER
4"	15"	3"	29"	2-1/4"	2-1/4" DUAL	PP214
4"	15"	3"	29"	2-1/2"	2-1/2" DUAL	PP2512
4"	15"	3"	29"	2-1/2"	2-1/4" DUAL	PP2514
4"	15"	3"	29"	3"	2-1/2" DUAL	PP3012
4"	15"	3"	29"	3"	2-1/4" DUAL	PP3014

304 GLASS PACKS

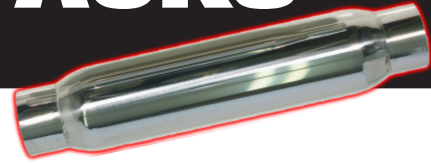

CASE DIAMETER	CASE LENGTH	CORE DIAMETER	OVERALL LENGTH	END SIZES	END POSITION	PART NUMBER
3-1/2"	12"	2-1/4"	16"	2-1/4"	STRAIGHT	3512RS
3-1/2"	15"	2-1/4"	19"	2-1/4"	STRAIGHT	3515RS
4"	12"	2-1/2"	16"	2-1/2"	STRAIGHT	4512RS
4"	15"	2-1/2"	19"	2-1/2"	STRAIGHT	4515RS
4"	12"	3"	16"	3"	STRAIGHT	4312RS
4"	15"	3"	19"	3"	STRAIGHT	4315RS

FLO Y

SINGLE SIZE	DUAL SIZE	OVERALL LENGTH	ALUMINIZED PART NUMBER	STAINLESS PART NUMBER
2" ID	2" ID	10"	Y2001	SY200
2-1/4" ID	2-1/4" ID	10"	Y2141	SY214
2-1/2" ID	2-1/2" ID	10"	Y2121	SY212
2-1/2" ID	2-1/4" ID	10"	Y252141	SY25214
3" ID	2-1/4" ID	10"	Y32141	SY3214
3" ID	2-1/2" ID	10"	Y32121	SY3212
3" ID	3" ID	10"	Y3001	SY300
4" ID	4" ID	14"	Y4001	SY400

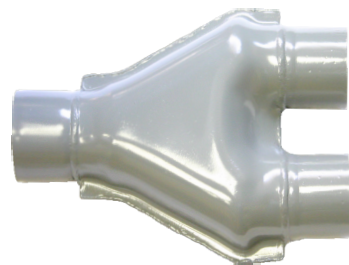

FLO X Crossover Pipes

SINGLE SIZE	DUAL SIZE	OVERALL LENGTH	ALUMINIZED PART NUMBER	STAINLESS PART NUMBER
2-1/4" ID	2-1/4" ID	12"	X2141	SX214
2-1/2" ID	2-1/2" ID	12"	X2121	SX212
3" ID	3" ID	12"	X3001	SX300



Header Collector Kits

HC1W

2-1/2" OD

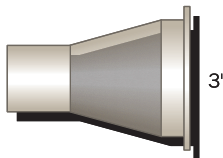

WITH 3/8"
WELDED
FLANGE

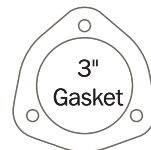

1/8" thick metal core

Kit Contains:

2 - 3" Collectors
2 - 3" Gaskets
2 - 3" Flanges

HC2W

3" OD

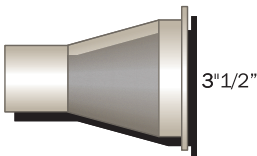

WITH 5/16"
WELDED
FLANGE

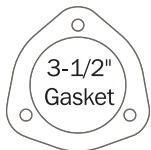

1/8" thick metal core

Kit Contains:

2 - 3-1/2" Collectors
2 - 3-1/2" Gaskets
2 - 3-1/2" Flanges

MANDREL BENDS

ALUMINIZED STEEL



Part Number	Size	Ends	Bend	A Length	B Length	Material
113180	1-1/2"	OD OD	180	8	8	Aluminized
213180	1-3/4"	OD OD	180	8	8	Aluminized
313180	2"	OD OD	180	8	8	Aluminized
413180	2-1/4"	OD OD	180	12	12	Aluminized
514180	2-1/2"	OD OD	180	12	12	Aluminized
614180	3"	OD OD	180	12	12	Aluminized
715180	3-1/2"	OD OD	180	12	12	Aluminized
11390	1-1/2"	OD OD	90	6	8	Aluminized
21390	1-3/4"	OD OD	90	6	8	Aluminized
31390	2"	OD OD	90	6	8	Aluminized
41390	2-1/4"	OD OD	90	8	16	Aluminized
51490	2-1/2"	OD OD	90	8	16	Aluminized
61490	3"	OD OD	90	8	16	Aluminized
71590	3-1/2"	OD OD	90	8	16	Aluminized
81690	4"	OD OD	90	12	18	Aluminized
82690	4"	ID OD	90	12	18	Aluminized
91890	5"	OD OD	90	12	18	Aluminized
92890	5"	ID OD	90	12	18	Aluminized
11345	1-1/2"	OD OD	45	6	8	Aluminized
21345	1-3/4"	OD OD	45	6	8	Aluminized
31345	2"	OD OD	45	6	8	Aluminized
41345	2-1/4"	OD OD	45	8	16	Aluminized
51445	2-1/2"	OD OD	45	8	16	Aluminized
61445	3"	OD OD	45	8	16	Aluminized
71545	3-1/2"	OD OD	45	8	16	Aluminized
81645	4"	OD OD	45	12	18	Aluminized
82645	4"	ID OD	45	12	18	Aluminized
91845	5"	OD OD	45	12	18	Aluminized
92845	5"	ID OD	45	12	18	Aluminized

MANDREL BENDS

POLISHED 304 STAINLESS STEEL



Part Number	Size	Ends	Bend	A Length	B Length	Material
153180	1-1/2"	OD OD	180	8	8	304 Polished
253180	1-3/4"	OD OD	180	8	8	304 Polished
353180	2"	OD OD	180	8	8	304 Polished
453180	2-1/4"	OD OD	180	12	12	304 Polished
554180	2-1/2"	OD OD	180	12	12	304 Polished
654180	3"	OD OD	180	12	12	304 Polished
755180	3-1/2"	OD OD	180	12	12	304 Polished
856180	4"	OD OD	180	16	16	304 Polished
15390	1-1/2"	OD OD	90	6	8	304 Polished
25390	1-3/4"	OD OD	90	6	8	304 Polished
35390	2"	OD OD	90	6	8	304 Polished
45390	2-1/4"	OD OD	90	8	16	304 Polished
55490	2-1/2"	OD OD	90	8	16	304 Polished
65490	3"	OD OD	90	8	16	304 Polished
75590	3-1/2"	OD OD	90	8	16	304 Polished
85690	4"	OD OD	90	12	20	304 Polished
95890	5"	OD OD	90	12	20	304 Polished
15345	1-1/2"	OD OD	45	6	8	304 Polished
25345	1-3/4"	OD OD	45	6	8	304 Polished
35345	2"	OD OD	45	6	8	304 Polished
45345	2-1/4"	OD OD	45	8	16	304 Polished
55445	2-1/2"	OD OD	45	8	16	304 Polished
65445	3"	OD OD	45	8	16	304 Polished
75445	3-1/2"	OD OD	45	8	16	304 Polished
85645	4"	OD OD	45	12	20	304 Polished
95845	5"	OD OD	45	12	20	304 Polished

MANDREL BENDS

LIGHTWEIGHT ALUMINUM



Part Number	Size	Ends	Bend	A Length	B Length	Material
373180	2"	OD OD	180	8	8	Aluminum
473180	2-1/4"	OD OD	180	12	12	Aluminum
574180	2-1/2"	OD OD	180	12	12	Aluminum
674180	3"	OD OD	180	12	12	Aluminum
37390	2"	OD OD	90	6	8	Aluminum
47490	2-1/4"	OD OD	90	8	16	Aluminum
57490	2-1/2"	OD OD	90	8	16	Aluminum
67490	3"	OD OD	90	8	16	Aluminum
37345	2"	OD OD	45	6	8	Aluminum
47445	2-1/4"	OD OD	45	8	16	Aluminum
57445	2-1/2"	OD OD	45	8	16	Aluminum
67445	3"	OD OD	45	8	16	Aluminum

THESE ALUMINUM BENDS WORK WELL FOR CUSTOM COLD AIR INTAKE MODS!

LAP JOINT CLAMPS

GREAT FOR DIY INSTALLATIONS



Size	Material	Part Number
2"	Aluminized	LJ200
2-1/4"	Aluminized	LJ225
2-1/2"	Aluminized	LJ250
3"	Aluminized	LJ300
4"	Aluminized	LJ400
4"	409 Stainless	LJ400SS
5"	Aluminized	LJ500
5"	409 Stainless	LJ500SS

DIRECT FITTED FLEX



DF1007

96-99 Pontiac Grand Am DOHC 2.4L
96-99 Pontiac Sunfire 2.4L
97-98 Chevrolet Malibu 4cyl 2.4L
98 Chevrolet Malibu 6cyl 3.2L
96-98 Buick Skylark DOHC 2.4L
96-98 Chevrolet Cavalier 2.4L
96-98 Oldsmobile Achieva DOHC 2.4L



DF1004

98-00 Chevrolet S-10 2.2L
98-00 GMC S-15 Sonoma 2.2L



DF1012

97-04 Chevrolet Monte Carlo 3.4L
99-03 Chevrolet Malibu 3.1L
97-00 Chevrolet Venture 3.4L
00-04 Chevrolet Impala 3.4L
97-04 Buick Century 3.1L
97-98 Buick Regal 3.1L
97-00 Oldsmobile Silhouette 3.4L
97-04 Pontiac Grand Prix 3.1L
97-00 Pontiac Montana/Transport 3.4L



DF1010

99-02 Chevrolet Cavalier 2.4L
1999 Chevrolet Malibu 2.4L
99-01 Oldsmobile Alero 'T' 2.4L
02-04 Oldsmobile Alero 'F' 2.2L
1999 Pontiac Grand Design #2 2.4L
99-01 Pontiac Grand Am SE 'T' 2.4L
02-04 Pontiac Grand Am 'F' 2.2L
99-02 Pontiac Sunfire 2.2L



DF1008

96-97 Chevrolet S-10 2.2L
96-97 GMC S-15 Sonoma 2.2L
96-97 Isuzu Hombre 2.2L



DF1005

98-99 Chevrolet Monte Carlo 3.8L
99-05 Chevrolet Cavalier Exc. '4' 2.2L
05-08 Chevrolet Cobalt 2.2L
06-07 Chevrolet Cobalt 2.4L
06-07 Chevrolet HHR 2.2L, 2.4L
2007 Pontiac G5 2.2L, 2.4L
05-07 Saturn Ion 1,2,3 2.2L, 2.4L



DF1003

97-01 Chevrolet Lumina 3.1L
2001 Chevrolet Impala 3.4L
97-99 Chevrolet Monte Carlo 3.0L
1997 Oldsmobile Cutlass Supr. 3.1L



DF1013

98-99 Oldsmobile Intrigue K 3.8L
99-02 Oldsmobile Intrigue 3.5L
97-03 Pontiac Grand Prix 3.8L



DF1002

95-00 Dodge Stratus 2.0L, 2.4L, 2.5L
98-00 Plymouth Breeze 2.0L
97-00 Plymouth Neon 2.0L
95-00 Chrysler Sebring 2.4L, 2.5L
96-97 Chrysler Cirrus 2.4L
95-98 Chrysler Cirrus LT 2.5L
01-07 PT Cruiser Turbo 2.4L

96-00 Dodge Caravan/Grand Caravan 2.4L
96-01 Dodge Caravan/Grand Caravan 3.3L
96-01 Dodge Caravan 3.8L
96-00 Dodge Grand Caravan 3.8L
96-00 Plymouth Voyager/Grand Voyager 2.4L
96-01 Plymouth Voyager 3.3L, 3.8L
96-00 Plymouth Grand Voyager 3.3L, 3.8L
96-00 Chrysler Town & Country 3.3L, 3.8L

DIRECT FITTED FLEX

DF1017



02-05 Chevrolet Cobalt DOHC 'F' 2.2L
05-08 Chevrolet Cobalt DOHC 'F' 2.2L
05-08 Chevrolet Cobalt 'B' 2.4L
06-08 Chevrolet HHR DOHC 2.2L, 2.4L
06-08 Pontiac G5 DOHC 2.2L
07-08 Pontiac G5 DOHC 2.4L

DF1016



97-04 Buick Regal 3.8L
00-05 Chevrolet Impala 'K' 3.8L
04-05 Chevrolet Impala SC 3.8L
1999 Chevrolet Lumina 'K' 3.8L
00-05 Chev Monte Carlo 'K' 3.8L
04-05 Chev Monte Carlo SC 3.8L
97-03 Pontiac Grand Prix 3.8L
1999 Pontiac GTP SC 3.8L
98-99 Oldsmobile Intrigue 'K' 3.8L
99-02 Oldsmobile Intrigue 3.5L

DF1006



Chevrolet Big Block (Left Side)

DF1014



Chevrolet Big Block (Right Side)

DF1015



95-00 Ford Contour V6 'AT' 2.5L
95-00 Mercury Mystique V6 'AT' 2.5L

DF1009



00-05 Ford Taurus DOHC 'S' 3.0L
00-07 Ford Taurus DOHC 'U' 3.0L
00-05 Mercury Sable DOHC 'S' 3.0L
00-07 Mercury Sable DOHC 'U' 3.0L

DF1011



98-00 Volkswagen 2.0L

DF1001



06-08 Volkswagen Jetta

BRAIDED FLEX

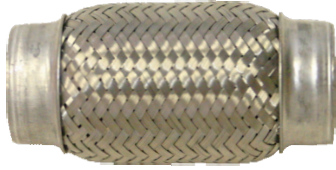

BLANK

Part #	Inlet	Outlet	Overall Length
FT17504B	1 3/4"	1 3/4"	4"
FT17506B	1 3/4"	1 3/4"	6"
FT17508B	1 3/4"	1 3/4"	8"
FT17510B	1 3/4"	1 3/4"	10"
FT20004B	2"	2"	4"
FT20006B	2"	2"	6"
FT20008B	2"	2"	8"
FT20010B	2"	2"	10"
FT22504B	2 1/4"	2 1/4"	4"
FT22506B	2 1/4"	2 1/4"	6"
FT22508B	2 1/4"	2 1/4"	8"
FT22510B	2 1/4"	2 1/4"	10"
FT25004B	2 1/2"	2 1/2"	4"
FT25006B	2 1/2"	2 1/2"	6"
FT25008B	2 1/2"	2 1/2"	8"
FT25010B	2 1/2"	2 1/2"	10"
FT30004B	3"	3"	4"
FT30006B	3"	3"	6"
FT30008B	3"	3"	8"
FT30010B	3"	3"	10"
FT35008B	3 1/2"	3 1/2"	8"
FT40008B	4"	4"	8"

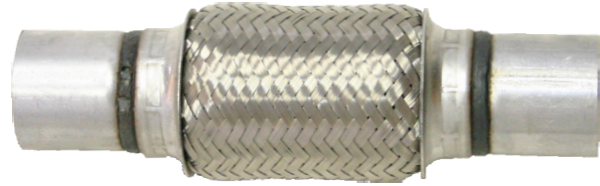

WITH ENDS

Part #	Inlet	Outlet	Overall Length
FT17504N	1 3/4"	1 3/4"	8"
FT17506N	1 3/4"	1 3/4"	10"
FT17508N	1 3/4"	1 3/4"	12"
FT17510N	1 3/4"	1 3/4"	14"
FT20004N	2"	2"	8"
FT20006N	2"	2"	10"
FT20008N	2"	2"	12"
FT20010N	2"	2"	14"
FT22504N	2 1/4"	2 1/4"	8"
FT22506N	2 1/4"	2 1/4"	10"
FT22508N	2 1/4"	2 1/4"	12"
FT22510N	2 1/4"	2 1/4"	14"
FT25004N	2 1/2"	2 1/2"	8"
FT25006N	2 1/2"	2 1/2"	10"
FT25008N	2 1/2"	2 1/2"	12"
FT25010N	2 1/2"	2 1/2"	14"
FT30004N	3"	3"	8"
FT30006N	3"	3"	10"
FT30008N	3"	3"	12"
FT30010N	3"	3"	14"
FT35008N	3 1/2"	3 1/2"	12"
FT40008N	4"	4"	12"

WITH INTERLOCK BRAID

BLANK

Part #	Inlet	Outlet	Overall Length
FT25006BIL	2 1/2"	2 1/2"	6"
FT30006BIL	3"	3"	6"



Aluminized 3 1/2" - 4" Adapter



354AD

UNIVERSAL HANGERS



J-Hook

MILD STEEL

Part #	Diameter	Length	QTY
RD1388	3/8"	8"	25

ZINC COAT

Part #	Diameter	Length	QTY
RD2388	3/8"	8"	25



RD20L
QTY 25



RD104
QTY 25



2-3/8"

RD554
QTY 25



RD107
QTY 25



RD107U
QTY 25

FORD ECO-BOOST

Do you want more **POWER** from your
F-150 Eco-Boost?
(2011-2014)



Our Original...
TWISTER
 RESONATOR
 Quiets down the drone!

4" Cat Back Single Exhaust

ALUMINIZED STAINLESS

2011-2014, 3.5L, F150 ECOBOOST

Non-Resonated, With Muffler	865	SS865
Resonated, With Muffler	865RS	SS865RS

TUNING OPTIONS

SCT
 MORE POWER! LESS FUEL!

5015 LiveWireTS

7015 Flash Device

+5-15% MPG

