



Electric Cooling Fan Models 410/420 & 430/440

Installation Instructions

Through Core Mounting Instructions (SEE DIAGRAM "A")

1. Position the electric fan against the back of the radiator, and mark the holes for mounting. (Some applications may have A/C condensers and/or transmission coolers on the front of the radiator. Additional adjustments or modifications may be necessary for installation)
2. Rotate fan blades to make sure they are free of obstructions.
3. With a small phillips screwdriver pass through the marked holes, carefully spread the fins to allow easy passage for the nylon bolts (4 for the single fan unit, 6 for the double fan unit). Pass the bolts through the shroud holes then twist the bolts through the radiator.
4. Slide the rubber washer, then the nylon washer onto the nylon bolt and finger tighten nylon nuts until snug.
5. Once again, rotate fan blades to insure that they are free of obstruction.

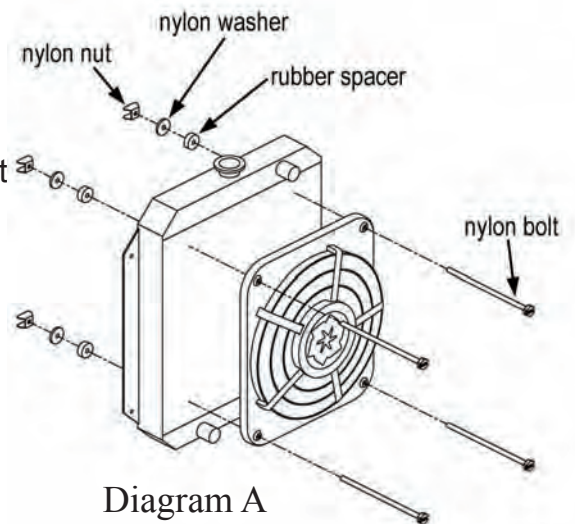

Diagram A

OR

Radiator Support Channel Or Frame Installation

(SEE DIAGRAM "B")

1. Attach frame mounting brackets to fan using nylon bolts, Cut them to 1", Use nylon nuts to secure.
2. Position fan to desired location, Mark holes on radiator channels or frame.
3. Rotate fan blades to ensure that they are free of obstructions.
4. On the marked hole locations, drill 13/64" holes.
5. Secure the fan to radiator using 1/4" self tapping screws.
6. Check again to be sure the fan blades rotate freely.

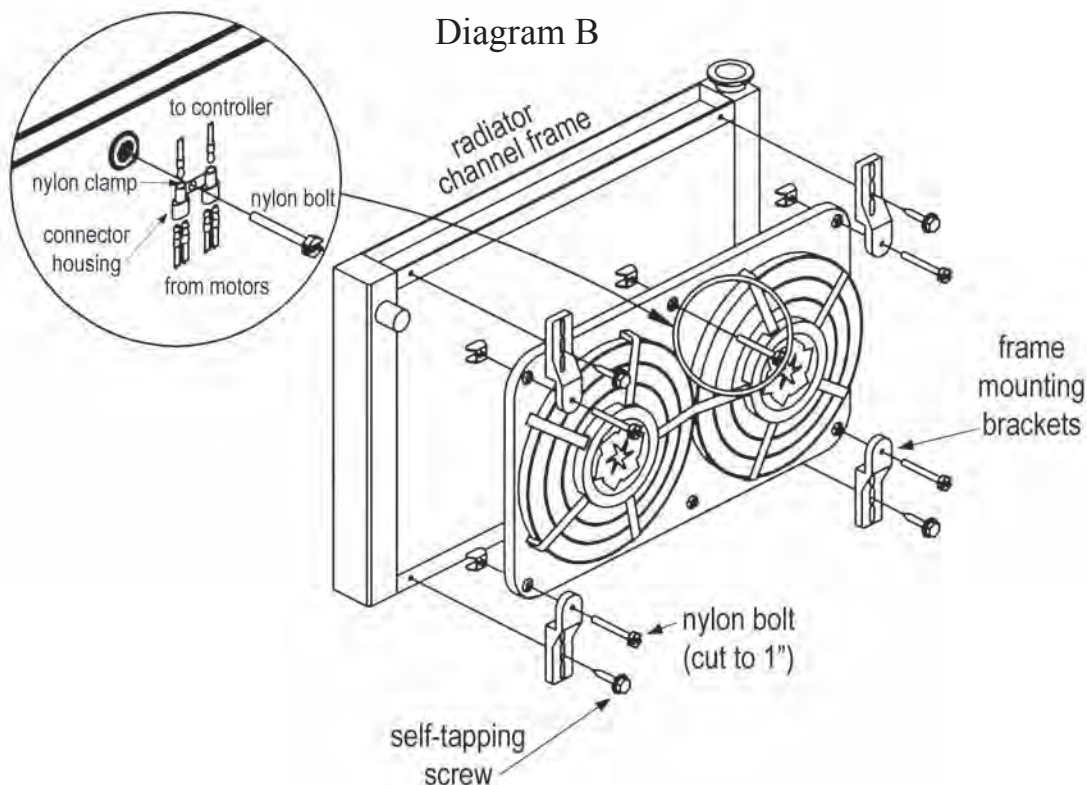

Diagram B

Wiring Instructions Model 410 & 430

NOTE: Models 420 and 440 do not include a fan control unit; skip to page 4 of instructions



FOLLOW THESE INSTRUCTIONS CAREFULLY TO AVOID DAMAGING THE CONTROL UNIT, FAN MOTORS, AND YOUR VEHICLE! WHEN CRIMPING WIRES, ALWAYS USE A QUALITY CRIMPING TOOL (DO NOT USE PLIERS OR OTHER DEVICES).

Step 1: Locate mounting point for the VSC (variable speed control) unit

Locate a mounting point for the VSC near inlet side of the radiator. The control unit needs to be placed within about 2' of radiator inlet hose. On the fender well next to the radiator may be a convenient location. Attach the control unit using the screws provided.

Step 2: Wire the fan motors (refer to Wiring Diagram, below)

Using the large, non-insulated bullet connectors provided, attach a length of the thick (12 AWG) **red** wire to the **red** motor wires at fan. Attach a length of the thick (12 AWG) **black** wire to the **black** motor wires at the fan. Once the fan is in place, these will attach to the control unit. If mounting the control somewhere in the engine compartment, leave enough wire to reach the control unit.

WIRING DIAGRAM - MODEL 410 (PULLER)

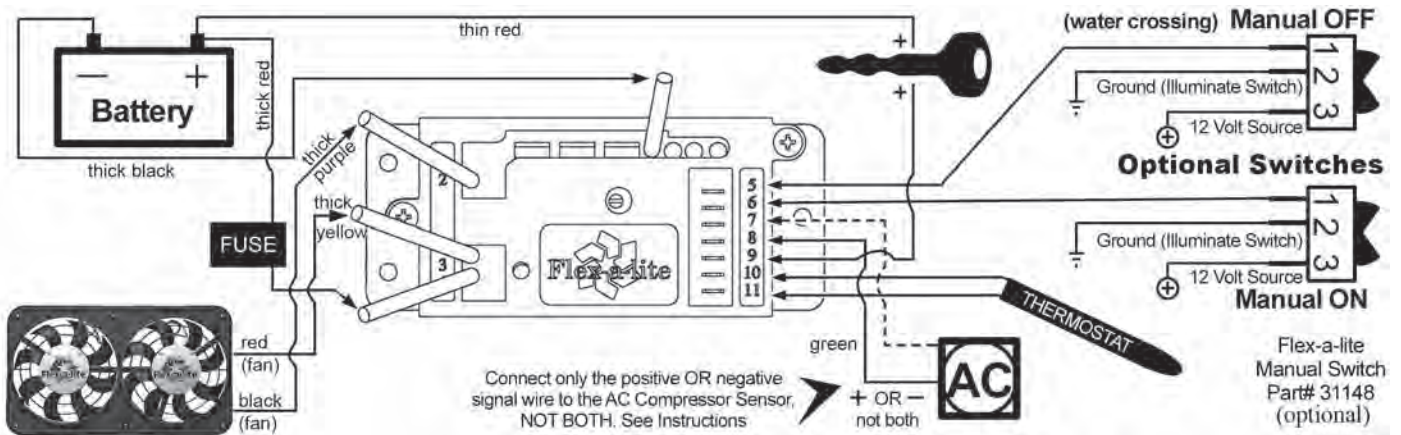

WIRING DIAGRAM - MODEL 430 (PUSHER)

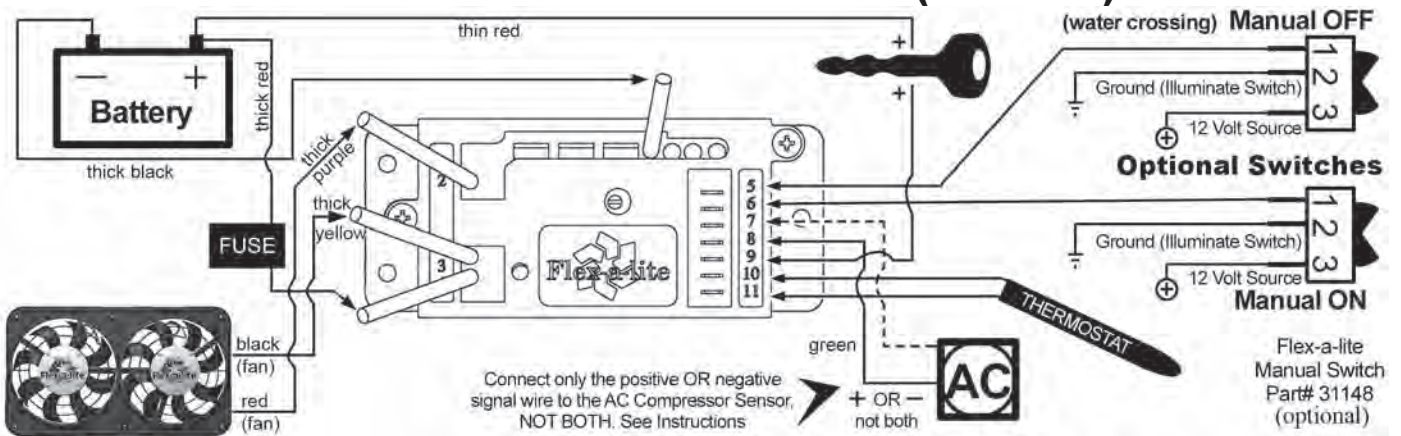

NOTE: If you have purchased a Model 410 fan, proceed to step 3A; If you have purchased a Model 430 fan, skip step 3A and proceed to step 3B.

3A. Connect the fan wires to the VSC (Model 410 puller fan only)

Now begin wiring the motors to the VSC. Using the large butt connectors provided, connect the **red** wire you attached to the fan motor wires in Step 2 to the **yellow** wire on the VSC. Connect the **black** wire from the motor wires to the **purple** wire on the VSC. (see Diagram 5 - next page) **NOTE: Failure to do this will result in incorrect operation and damage to fan motors!**

3B. Connect the fan wires to the VSC (Model 430 pusher fan only)

Now begin wiring the motors to the VSC. Using the large butt connectors provided, connect the **black** wire you attached to the fan motor wires in Step 2 to the **yellow** wire on the VSC. Connect the **red** wire from the motor wires to the **purple** wire on the VSC. (see Diagram 6 - next page) **NOTE: Failure to do this will result in incorrect operation and damage to fan motors!**

4. Connect power leads

Determine the length needed run thick red and black wire from the VSC to the battery terminals and trim appropriately. Crimp a large yellow ring connector to one end of the each wire and connect the black wire to the negative (-) battery terminal, but **do not** connect the red wire yet. Using butt connectors, connect the fuse holder provided inline with the red wire. The fuse and fuse holder will protect the fan motors and your vehicle's electrical system from damage.

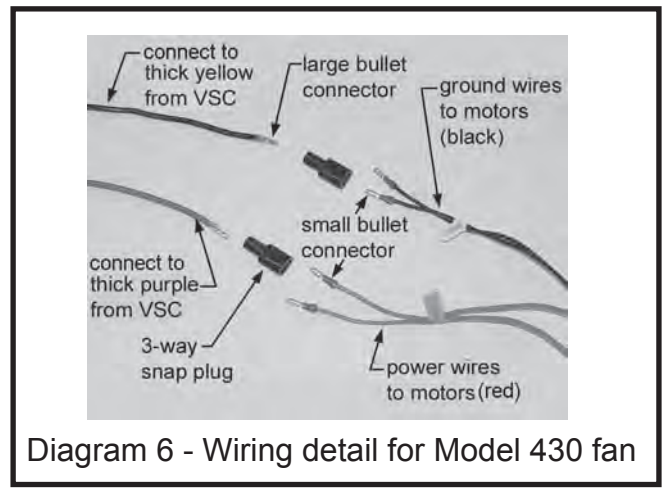
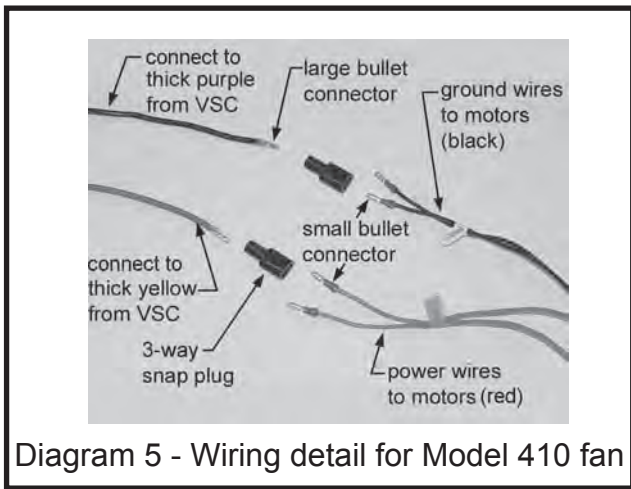

Wiring Instructions Cont'd. 410 & 430

6. Ignition controlled power source

Locate fuse box. Find a circuit that is "hot" when the key is in the "ON" position. **NOTE: DO NOT use the DRL or brake/taillight fuse!** Attach the included fuse tap to fuse. Attach a female connector to the thin red wire included and connect to the fuse tap. Trim the wire so that it will reach the VSC. Attach pink female connector to end of wire and connect to **terminal #9** on VSC.

7. Fan operation with air conditioning

Locate the wires coming from the A/C compressor. Determine which wire is ground and which is positive by using a volt meter. Connect the positive wire to the supplied thin green wire by use of a piggyback connector. Determine length needed to reach VSC and trim to length. Attach a pink female connector to the wire. If the A/C compressor is activated by a positive (+) signal, connect this wire to **terminal #8** on VSC. If it is activated by a negative signal, connect to **terminal #7** on VSC.

8. Temperature sensor

Locate the temperature sensor. Gently push probe through fins in radiator as close to the upper radiator hose as possible, leaving about 1/4" of the probe protruding out of the core. The rubber cap should be used when possible to insulate any of the probe coming through the front side of the radiator. Determine length of wire needed to reach VSC. **IMPORTANT:** Strip the insulation back about 1" and fold the wire onto itself to effectively double the thickness of the wire before connecting the pink female connectors as shown in at right. Attach these wires to **terminals #10 & 11** on the VSC. Both wires need to be connected but it doesn't matter which wire goes to each terminal.

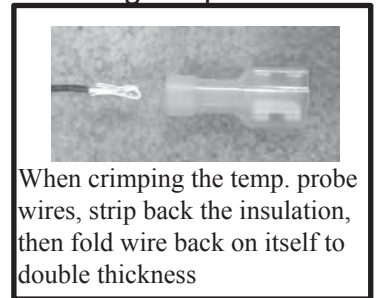
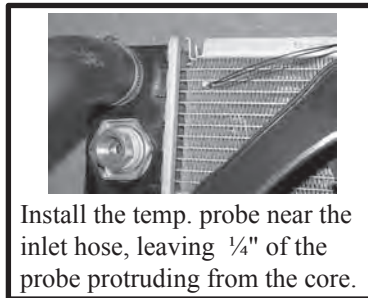

9. Manual Switch

If manual switches (Flex-a-lite #31148) have been purchased, attach them as follows: To override engine temperature signal and turn fans off, connect the switch to **terminal #5** on VSC to send a negative (-) signal. To override engine temperature signal and turn fans on, connect the switch to **terminal #6** on the VSC so that a negative (-) signal is sent.

WIRING CONNECTIONS

- | | |
|--|--|
| <ul style="list-style-type: none"> #1 Battery Negative* #2 Negative to Fan* #3 Positive to Fan* #4 Battery Positive* #5 Negative Override Signal OFF #6 Negative Override Signal ON #7 A/C Compressor Negative Signal | <ul style="list-style-type: none"> #8 A/C Compressor Positive Signal #9 Ignition Positive Signal* #10 Temp Sensor Wire* #11 Temp Sensor Wire* L1 Fan Output Indicator L2 Override Condition Indicator L3 A/C Signal Indicator L4 Ignition Signal Indicator |
|--|--|

* mandatory connections

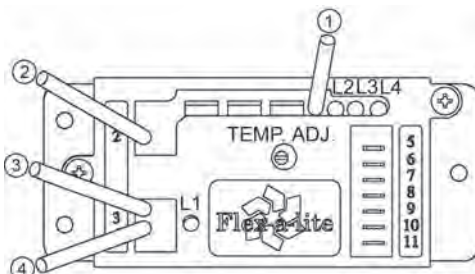

The Variable Speed Control has new features.

At the set temperature, the fans will come on at 60%; this reduces the load on your charging system. If the temperature rises, the fan speed will increase. If your set temperature is 195°F, then between 195° and 205° the fan speed will increase from 60% to 100%. So after a 10-degree rise from the set point, the fans will be running at 100%.

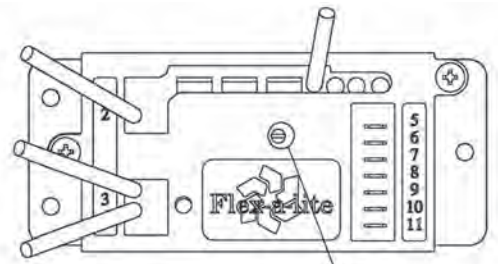

NOTE: Maximum rotation of adjusting screw is $\frac{3}{4}$ turn!



Initial Start-up and Adjustment Procedure

1. Turn ignition on. After 6 seconds, LED #L4 should light up. If not, check to make sure that there is 12 Volts at terminal #9 on VSC. The delay is to allow starter to start the vehicle without the fans drawing any power.
2. With your engine running, engage the A/C. The fans should come on and cycle with the A/C compressor. LED's #L1, L3 and L4 should be lit when fans are running. If they do not turn on, verify that the A/C clutch is engaged and make sure you have a positive signal when the clutch is engaged at terminal #8 on the VSC. Shut off A/C and let engine continue to idle, or drive the vehicle a short distance to bring the engine to operating temperature (monitor the vehicle's temperature gauge).
3. Verify that operating temperature has been reached by feeling the upper radiator hose. Hot water should be flowing through hose into the radiator. If the fans have not cycled on yet, slowly adjust the screw on the VSC until the fans cycle on. Turning the screw further in this direction will keep the engine at a lower temperature, and turning in the opposite direction will keep the engine at a higher temperature. **NOTE: THE TOTAL MOVEMENT OF THE ADJUSTMENT SCREW IS ABOUT $\frac{3}{4}$ OF A TURN. TURNING THE SCREW BEYOND THE LIMITS WILL DAMAGE THE UNIT!** Once desired temperature is set, let the engine continue to idle and make sure the fans will cycle to maintain desired temperature. When fans are running, LED's #L1 and L4 should be lit.

Wiring Instructions - Model 420 & 440

1A. (Model 420 puller fan only): Wire the fan motors to power source (control unit or switch and relay if desired). Connect the **red** wires from the fan motors to a 12v. positive (+) source. Connect the **black** motor wires to a ground (-) source. **NOTE: Failure to do this will result in incorrect operation and damage to the fan motors!**

1B. (Model 440 fan only): Wire the fan motors to a power source (control unit or switch and relay if desired). Connect the **black** wires from the fan motors to a 12v. positive (+) source. Connect the **red** motor wires to a ground (-) source. **NOTE: Failure to do this will result in incorrect operation and damage to the fan motors!**

2. Connect the fuse holder. Be sure to connect the provided fuse holder in-line with the positive (+) power wire to protect the fan motors and your vehicle's electrical system from damage.