

Spacers & Adapters

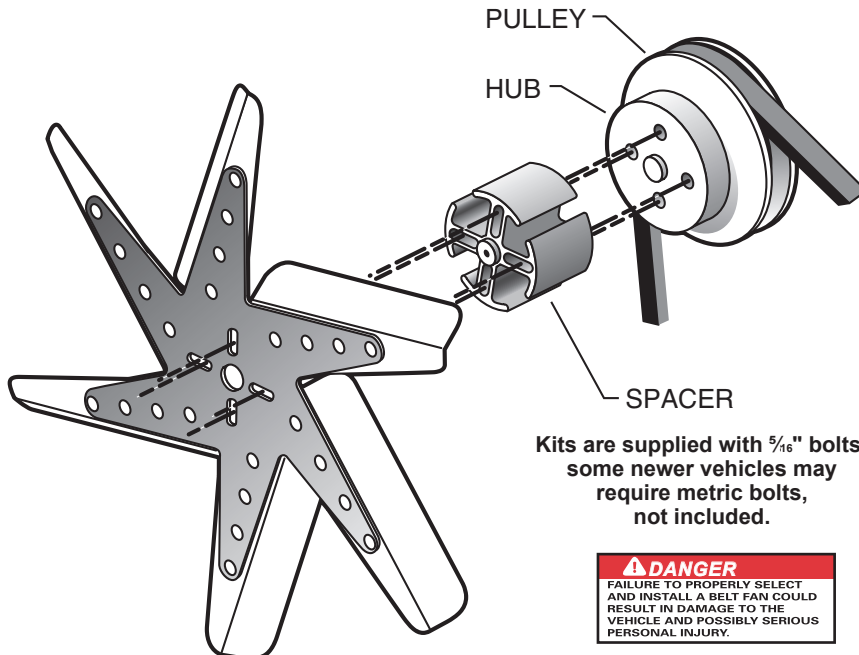

⚠ DANGER
FAILURE TO PROPERLY SELECT AND INSTALL A BELT FAN COULD RESULT IN DAMAGE TO THE VEHICLE AND POSSIBLY SERIOUS PERSONAL INJURY.

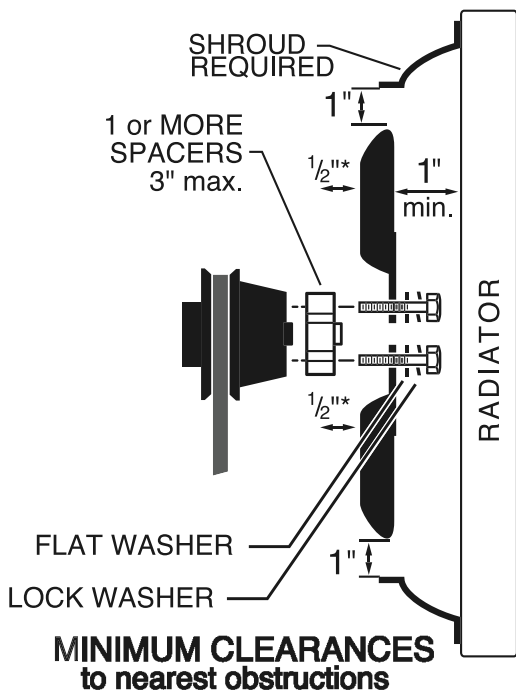

The bearing surface on a Flex-a-lite spacer face is larger and machined to a soft radius. This reduces point-loading, the most frequent cause of stress cracking on the fans center star.

This is why we strongly recommend Flex-a-lite spacers be used with Flex-a-lite (or any other) brand of belt fans.

Using any other brand of spacer will void the warranty on a Flex-a-lite fan.

Positioning a Shrouded Fan

When removing an O.E. fan clutch from your engine, a spacer is required to bring your new fan back into the "sweet spot" in the shroud opening. Allow 1" clearance to the fan shroud opening, and observe the other minimum clearances as shown above.

Fan Positioning Guidelines

For stock engine set-ups, refer to the Application Guide for size of spacers required. For engine swaps, check the clearances in your engine compartment and select the spacer(s) you need accordingly. Multiple spacers may be used, up to a maximum of 3".

Spacers & Adapters

Fan Spacers only



Mill Finish • standard 5/8" pilot

Spacer Adapters



Spacer Adapters convert a variety of Hub Pilot Diameters to a standard 5/8" pilot, and provide the required spacing from the radiator.
Mill Finish

Part# 501, 504, 508, 516			
Part#	Thick	Bolt	Mat'l
501	3/32"	1"	Aluminum
504	1/2"	1 1/4"	Aluminum
508	1"	1 3/4"	Aluminum
516*	2"	2 3/4"	Aluminum

*Use #516 when replacing a clutch fan (most applications)

Part# 832, 833, 836, 838, 840, 872			
Part#	Thick	Hub Pilot Diameter	Bolt Req'd
832	1/2"	3/4"	1 1/4"
833	1/2"	13/16"	1 1/4"
836	1/2"	1"	1 1/4"
838	1/2"	1 1/8"	1 1/4"
840	1/2"	1 1/4"	1 1/4"
872	1"	3/4"	1 3/4"

Fan Spacer Kits



Includes: Spacer plus 4 ea. screws and washers.

Part# 873, 876, 878, 879, 880, 952, 960			
Part#	Thick	Hub Pilot Diameter	Bolt Req'd
873	1"	.860"	1 3/4"
876	1"	1"	1 3/4"
878	1"	1 1/8"	1 3/4"
879	1"	1"	1 3/4"
880	1"	1 1/4"	1 3/4"
952	2"	3/4"	2 3/4"
960	2"	1 1/4"	2 3/4"

Part# 14524, 14528, 14536			
Chrysler Part#	Thick	Finish	Bolts
14524	1/2"	Mill	5/16"-18 x 1 1/4"
14528	1"	Mill	5/16"-18 x 1 3/4"
14536	2"	Mill	5/16"-18 x 2 3/4"

Part# 14544, 14548, 14556			
Ford,GM, AMC Part#	Thick	Finish	Bolts
14544	1/2"	Mill	5/16"-24 x 1 1/4"
14548	1"	Mill	5/16"-24 x 1 3/4"
14556	2"	Mill	5/16"-24 x 2 3/4"

Part# 814538			
Ford & Corvette application with 3/4" hub pilot	Thick	Finish	Bolts
14538	2"	Mill	5/16"-24 x 2 3/4"

*Will not work on newer applications that use metric bolts

⚠ WARNING
Must use Flex-a-lite Spacer or warranty will be voided

Screw-on Spacer/Adapter



This spacer/adapter replaces the fan clutch and hub by simply screwing onto the water pump. The fan bolts directly to the new spacer adapter.

The motion of the fan tightens spacer/adapter and **may require additional spacers, depending on application.**

The spacers are 1 1/2" thick.

For Ford, GM and some Chrysler applications.

Part# 851, 852		
Part#	Thread Pitch	Thread Direction
851	30mmx1.5	Right Hand rev. rotation
852	30mmx1.5	Left Hand std. rotation