

Installation of this kit requires a minimum of 6" of clearance between the tire side wall and the vehicle frame and a 1/2" of clearance around the air spring when inflated.

INSTALLATION INSTRUCTIONS

Congratulations - your new Air Helper Springs are quality products capable of improving the handling and comfort of your vehicle. As with all products, proper installation is the key to obtaining all of the benefits your kit is capable of delivering. Please take a few minutes to read through the instructions to identify the components and learn where and how they are used. It is a good idea to start by comparing the parts in your kit with the parts list below.

The heart of the kit is, of course, the air springs. Remember that the air springs must flex and expand during operation, so be sure that there is enough clearance to do so without rubbing against any other part of the vehicle.

Be sure to take all applicable safety precautions during the installation of the kit. The instructions listed in this brochure and the illustrations all show the left side of the vehicle. To install the right side assembly simply follow the same procedures.

This kit includes inflation valves and air lines for each air spring. This will allow you to compensate for unbalanced loads. If you would rather have a single inflation valve system to provide equal pressure to both air springs, your dealer can supply the optional "T" fitting.

WARNING:

Do not inflate this assembly when it is unrestricted. The assembly must be restricted by the suspension or other adequate structure. Do not inflate beyond 100 psi. Improper use or over inflation may cause property damage or severe personal injury.

IMPORTANT!

For your safety and to prevent possible damage to your vehicle, do not exceed the maximum load recommended by the vehicle manufacturer (GVWR). Although your Air Helper Springs are rated at a maximum inflation pressure of 100 psi, this pressure may allow you to carry too great a load on some vehicles. Check your vehicle owner's manual or manufacture plate on driver side door for maximum loads listed for your vehicle.

When inflating your Air Helper Springs, add air pressure in small quantities, checking pressure frequently during inflation. The air spring requires much less air volume than a tire and, therefore, inflates much quicker.

PARTS LIST

AIR SPRINGS	9000	2	3/8" SPECIAL FLAT WASHERS	8
UPPER BRACKETS	5377	2	5/16" FLAT WASHERS	4
LOWER BRACKETS	5489	2	PUSH TO CONNECT	
DISK	5260	2	INFLATION VALVES	3098 2
BRACKET STRAPS	5086	2	VALVE CAPS	2
AIR LINE TUBING		1	PUSH TO CONNECT	
3/8"-16 X 4" HEX BOLTS		8	ELBOW FITTINGS	3101 2
3/8"-16 FLANGE LOCK NUTS		12	NYLON TIES	6
3/8"-16 X 3/4" FLANGE HEX BOLTS		6	THERMAL SLEEVES	2
3/8"-16 X 4.5" CARRIAGE BOLTS		4	CAUTION TAG	2

FIGURE "A"

NOTE: Both illustrations are of the right, or passenger's, side of the vehicle. Reverse any orientations when assembling and installing the left, or driver's, side.
Both air springs mount behind the axle.

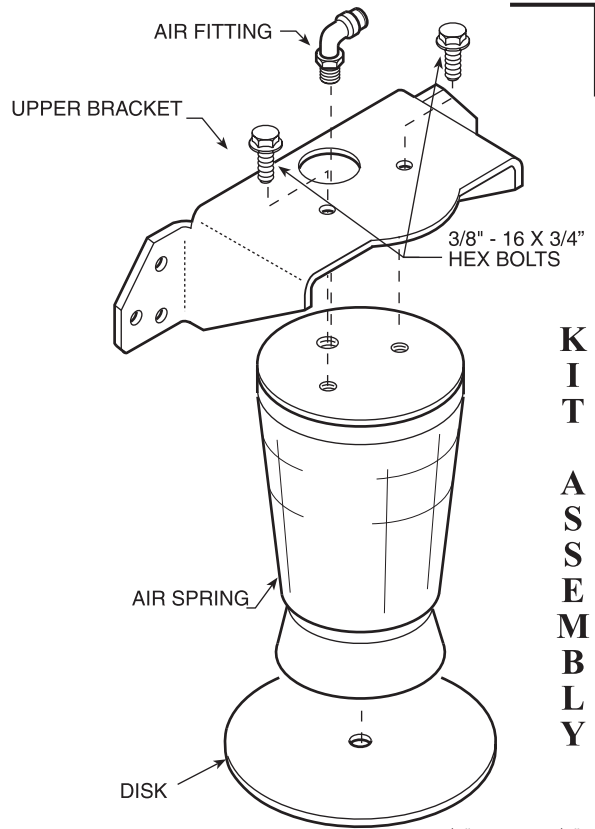

**K
I
T
A
S
S
E
M
B
L
Y**

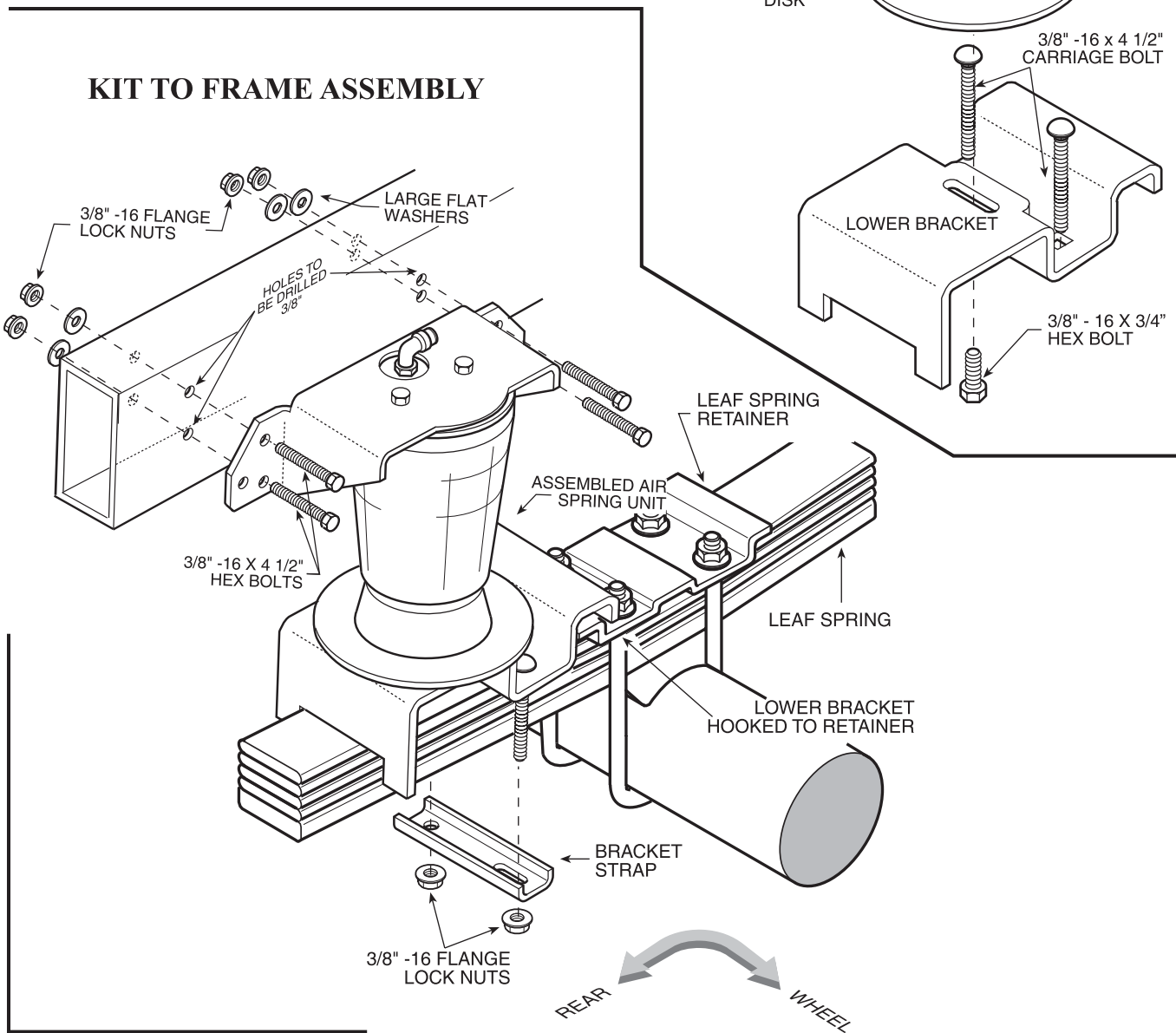

KIT TO FRAME ASSEMBLY



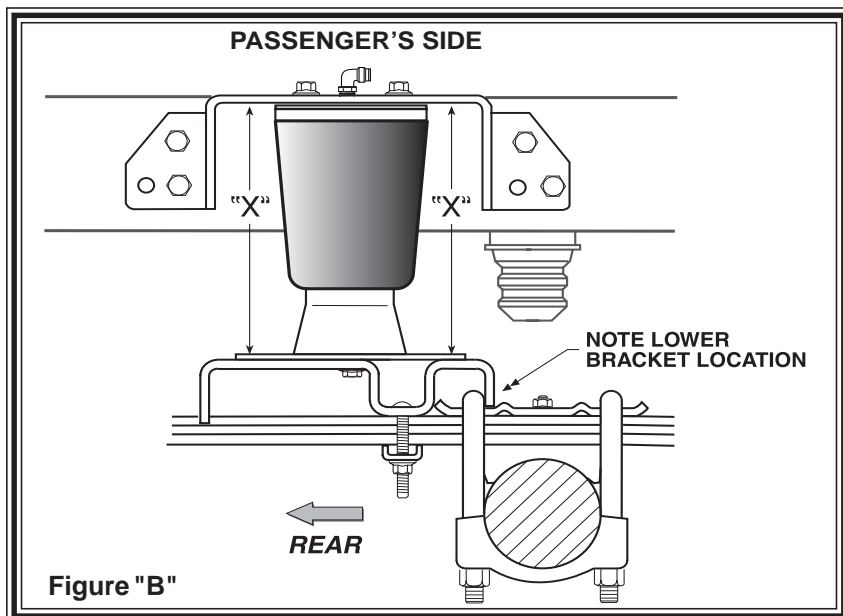

STEP 1 - PREPARE THE VEHICLE

With the vehicle on a solid, level surface chock the front wheels. Raise the vehicle by the axle and remove the rear wheels. After the removal of the wheels, lower the vehicle so the axle rests on jack stands rated for your vehicles weight. Remove the negative battery cable.

THE "X" DIMENSION.

Throughout this manual we refer to an "X" dimension. This is the initial, un-inflated overall height of the air spring. Both right and left sides should be installed at the same height. The "X" dimension on this air spring is 7" to 8". The air spring may require some stretching to achieve this dimension.

STEP 2 - PRE-ASSEMBLE THE KIT

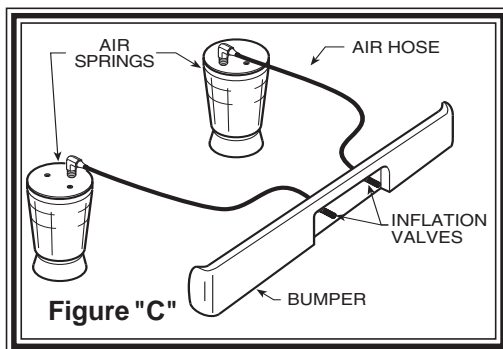

Select one air helper spring from your kit. Install the upper bracket by aligning the three holes on the air spring with the holes on the upper bracket. Fasten the upper bracket to the air spring using the 3/8" x

3/4" flange hex bolts as shown in *Figure "A"*. Install the air fitting as shown in *Figure "A"*. Tighten the air fitting to make contact with the Teflon ring and then tighten an additional 1/2 turn. No thread sealant is needed. Insert the two 3/8" x 4 1/2" carriage bolts into the lower bracket. Next, attach the lower bracket and disk to the air spring using the 3/8" x 3/4" flange hex bolt (see *Figure "A"*). Note: Finger tighten the bolt securing the lower bracket and disk allowing the air spring to move freely. **This will be tightened after alignment in Step 6.**

STEP 3 - ATTACH LOWER BRACKET TO LEAF SPRING

Place the assembly on the right side on top of the leaf spring stack rearward of the axle (see *Figure "A" and "B"*). Attach the lower bracket to the leaf stack using the 3/8" x 4 1/2" carriage bolts (installed earlier), the bracket strap, and the flange lock nuts as shown in *Figure "A" and "B"*. (Tighten to 15-20 ft. lbs.)

STEP 4 - MARK AND DRILL HOLES IN THE FRAME RAIL

Visually align the air spring so that it is vertically straight and the upper and lower brackets are parallel. Place the upper bracket so the top of the bracket is parallel with the top of the frame rail. See *Figure "A" and "B"*. Check the "X" dimension on both sides of the air spring, these dimensions should be the same (refer to *Figure "B"*).

Before drilling the holes make sure all electrical, brake and fuel lines are cleared from the path of the drill. In order to prevent any damage to these lines it is recommended that a piece of wood be placed between the frame rail and the existing lines during drilling. With the air spring assembly in place, mark the upper left hole with a center punch. Drill the hole using a 3/8" drill bit.

STEP 5 - ATTACHING THE UPPER BRACKET

Once the hole has been drilled, attach the upper bracket using the 3/8"-16 x 4 1/2" hex bolt, large flat washer, and the flange hex nut to the frame rail (finger tight). This will allow you to adjust the upper bracket. Once the positioning of the upper bracket is parallel to the lower bracket and the "X" dimensions are equal, drill the remaining three holes in the frame rail using the upper bracket as a template. Use the 3/8"-16 x 4 1/2" hex bolts, large flat washers, and flange hex nuts to fasten the upper bracket to the frame rail. See *Figure "A"*. **Once the upper bracket is secure, align the bottom of the air spring side to side to ensure that it is vertical. Tighten the bolt securing the lower bracket to the air spring.**

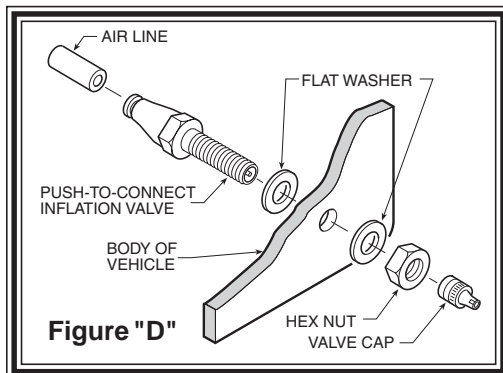

STEP 6 - INSTALLATION OF THE RIGHT SIDE ASSEMBLY

Follow steps 1-5, reversing all orientations, for assembly and installation of the driver's side assembly. Both air helper springs will install just to the rear of the axle.

STEP 7 - INSTALL THE AIR LINE AND INFLATION VALVE

Uncoil the air tubing and cut it into two equal lengths. *DONOT FOLD OR KINK THE TUBING*. Try to make the cut as square as possible. Insert one end of the tubing into the elbow fitting installed in the top of the air helper spring. Push the tubing into the fitting as far as possible.

Select a location on the vehicle for the air inflation valves. This can be on the bumper or the body of the vehicle, as long as it is protected so the valves will not be damaged (*see Figure "D"*). Drill a 5/16" hole and install the air inflation valve using two 5/16" flat washers per valve as supports (*see Figure "E"*). Route the tubing from the air helper spring to the inflation valve, avoiding direct heat from the engine, exhaust pipe, and away from sharp edges. The air line tubing should not be bent or curved sharply as it may buckle with age. Secure the tubing in place with the nylon ties provided. Push the end of the air line tubing into the inflation valve as illustrated (*see Figure "E"*).

STEP 8 - CHECK THE AIR SYSTEM

Once the inflation valves are installed, inflate the air helper springs to 50 psi and check the fittings for air leaks with an applied solution of soap and water. If a leak is detected, deflate the air spring by depressing the valve core. The tubing can easily be removed from the fittings by pushing the collar on the fitting towards the body of the fitting while pulling out the tube. Next, check the tubing connection to ensure that the air tubing is cut as square as possible and that it is pushed completely into the fitting.

If a leak is detected where the air fitting screws into the air spring, gently tighten the air fitting into the spring until the leak stops. Also, check the core of the inflation valve. This valve core can be tightened using the cap. Re-inflate the air spring and check for leaks again if needed.

This now completes the installation. Install the wheels and torque the lug nuts to the manufacturer's specifications. Raise the vehicle by the rear axle and remove the jack stands and lower the vehicle back onto the ground. Re-attach the negative battery cable and remove the wheel chocks from the front wheels. Before proceeding, check once again to be sure you have proper clearance around the air springs. **With a load on your vehicle and the air helper springs inflated, you must have at least 1/2" clearance around the air springs.** As a general rule, the Air Helper Springs will support approximately 30 lbs. of load for each psi of inflation pressure (per pair). For example, 50 psi of inflation pressure will support a load of approximately 1500 lbs. per pair of air helper springs. *FOR BEST RIDE* use only enough air pressure in the air helper springs to level the vehicle when viewed from the side (front to rear). This amount will vary depending on the load, location of load, condition of existing suspension and personal preference.

NOTE:

Too much air pressure in the air helper springs will result in a firm ride, while too little air pressure will not allow the improvement in ride and handling that is possible. **TO PREVENT POSSIBLE DAMAGE MAINTAIN A MINIMUM OF 10 psi IN THE AIR HELPER SPRINGS AT ALL TIMES. AFTER LOADING, YOU MAY USE UP TO 100 psi PER SIDE TO LEVEL THE TRUCK.**

WHEN THE TRUCK IS LIFTED INTO THE AIR FOR SERVICE, DEFLATE BOTH AIR SPRINGS COMPLETELY. AFTERWARDS, RE-INFLATE TO 10 psi PRIOR TO DRIVING.

NOTE:	
MIN PRESSURE	10 PSI
MAX PRESSURE (LOADED)	100 PSI