



Installation Instructions

Dodge Winch Bumper

Product Number: A1050-A1052

Application: '03-'05 Dodge Ram 2500-3500

SAFETY

Your safety and the safety of others is very important.

- In order to help you make informed decisions about safety, we have provided installation instructions and other information.
- These instructions alert you to potential hazards that could hurt you or others.
- Please do a job safety analysis (JSA) before each task to identify potential hazards for your situation and remove/protect against them.
- You must use your own good judgment, and take your time.

Read and understand all safety precautions and instructions before installing this product.

THIS PRODUCT IS FOR OFFROAD USE ONLY. ALL LIABILITY FOR INSTALLATION AND USE RESTS WITH THE OWNER.

CARELESS INSTALLATION AND OPERATION CAN RESULT IN SERIOUS INJURY OR EQUIPMENT DAMAGE.

Injury hazard

Failure to observe these instructions could lead to severe injury or death.

- Always** remove jewelry and wear eye protection.
- Always** use extreme caution when jacking up a vehicle for work. Set emergency brake and use tire blocks. Locate and use the vehicle manufacturers designated lifting points. Use jack stands.
- Always** use appropriate and adequate care in lifting components into place.
- Always** insure components will remain secure during installation and operation.
- Always** wear safety glasses when installing this kit. A drilling operation will cause flying metal chips. Flying chips can cause serious eye injury.
- Always** use extreme caution when drilling on a vehicle. Thoroughly inspect the area to be drilled (on both sides of material) prior to drilling, and relocate any objects that may be damaged.
- Always** use extreme caution when cutting and trimming during fitting.
- Always** tighten all nuts and bolts securely per installation instructions.
- Always** route electrical cables carefully. Avoid moving parts, components that become hot and rough or sharp edges.
- Always** insulate and protect all exposed wiring and electrical terminals.
- Always** perform regular inspections and maintenance on mounts and related hardware.



Installation Instructions

Dodge Winch Bumper

Product Number: A1050-A1052
Application: '03-'05 Dodge Ram 2500-3500

I. Overview

Congratulations on your purchase of the industries' best and most stylish 3rd gen Dodge Winch Bumper! This bumper has been **engineered** for strength while keeping the weight down. It can accept the Warn 16.5 winch... and look cool doing it.

This product has also been **engineered** to allow alignment in three directions so you will end up with a very professional fit.

Your bumper was designed, cut, fabricated, and powder coated... all in the U.S.A.

Enjoy the fit and finish of a quality Dodge Winch Bumper from Fab Fours Inc!

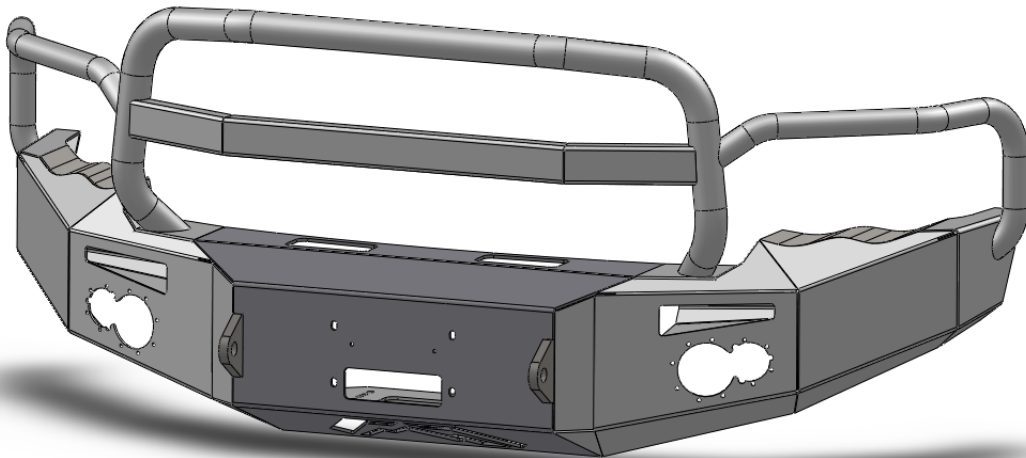



Installation Instructions

Dodge Winch Bumper

Product Number: A1050-A1052
Application: '03-'05 Dodge Ram 2500-3500

II. Tools Required

- Electric Drill
- 9/16" Drill bit
- Electric Hand Grinder
- Pry Bar
- Socket Wrench With Extension
- 10mm or 13mm Socket (year dependent)
- 18mm Socket
- 3/4" Socket
- 3/4" Open End Wrench
- 7/16" Open End Wrench
- 3/8" Open End Wrench
- 1/8" Allen Wrench
- 5/32" Allen Wrench
- Center punch
- Hammer
- Tin Snips

III. Vehicle Preparation

1. Open the hood.
2. [Diesel Models Only]. Remove the two fasteners (10mm or 13mm socket) holding the top of the intercooler to the radiator support. See Image Below:

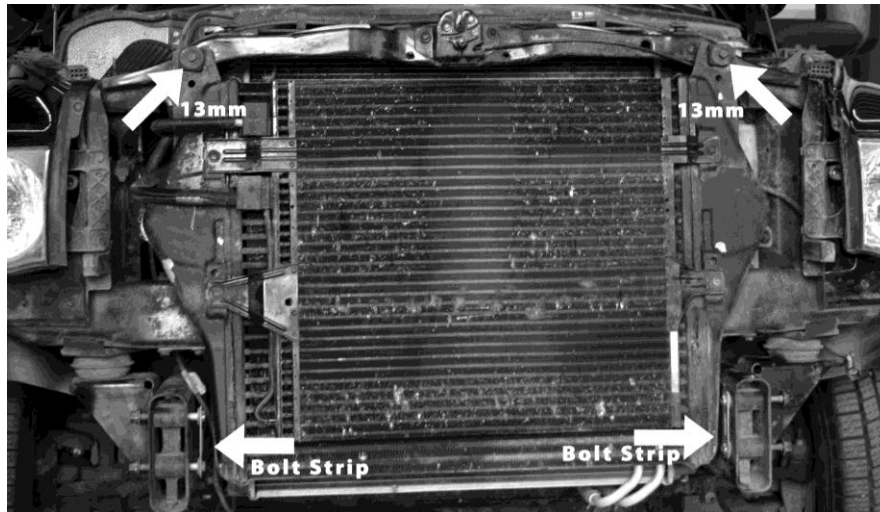

Figure 1 – Intercooler Fasteners

3. Disconnect the fog light harness from underneath the driver's side headlamp.
4. Remove the two nuts from the bolt strip on each frame rail.
5. One side at a time, lift the intercooler assembly to allow the bolt strip to be removed from the frame. **MAKE SURE THE BUMPER IS SUPPORTED BEFORE REMOVING THE BOLT STRIPS.** Be careful not to damage the radiator and intercooler fins.



Installation Instructions

Dodge Winch Bumper

Product Number: A1050-A1052
Application: '03-'05 Dodge Ram 2500-3500

6. Remove the OEM bumper assembly.
7. [Diesel Models Only] Retighten the intercooler mounting fasteners loosened in step 2.
8. Install the supplied template on the outside of the frame rail and drill the two lower holes. See template orientation below, Check both side of the frame rail before drilling:

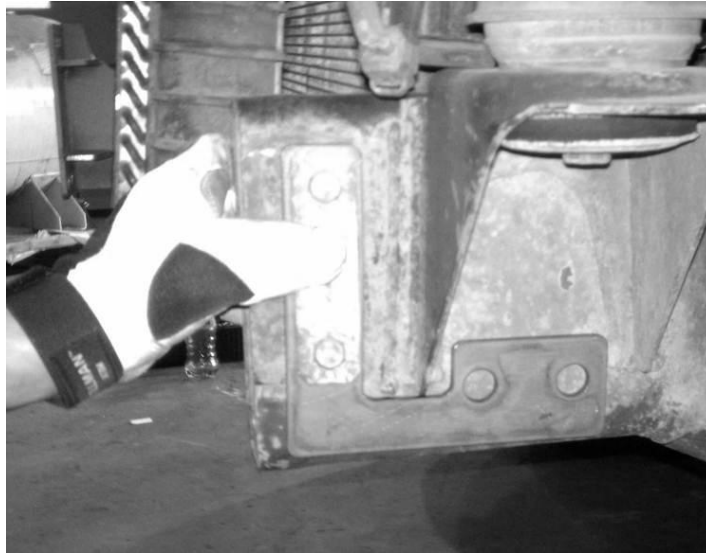

Figure 2 – Drilling Template

9. Use a large screwdriver to pry the anti-crush spacer out of the front of the frame rail; it is not necessary to completely remove it from the frame:

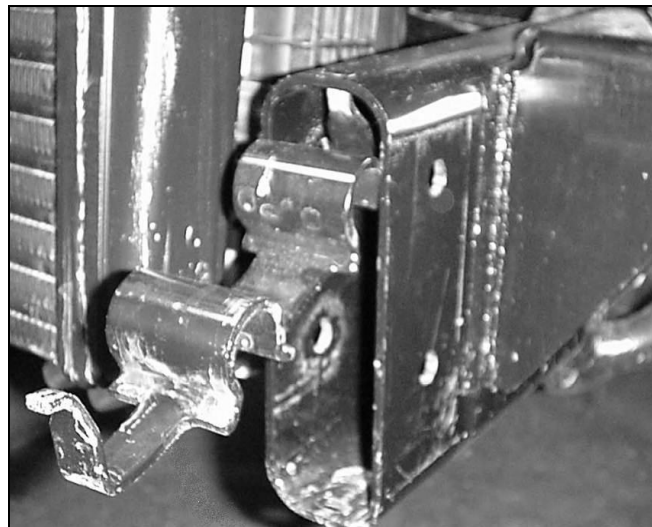

Figure 3 – Outer Bumper Support Screws



Installation Instructions
Dodge Winch Bumper
Product Number: A1050-A1052
Application: '03-'05 Dodge Ram 2500-3500

- 10.** Insert the provided U-shaped anti-crush spacers into the frame rail and line them up with the drilled holes.
- 11.** Push the OEM anti-crush spacer back into the frame rail so it lines back up with the OEM bumper mounting holes.
- 12.** Repeat steps 8-11 for the opposite frame rail.
- 13.** Your Truck is now ready for the installation of your New FAB FOURS BUMPER!



Installation Instructions

Dodge Winch Bumper

Product Number: A1050-A1052
Application: '03-'05 Dodge Ram 2500-3500

IV. Lights and Wiring Installation

1. Remove headlights following procedure in owner's manual. On each side, tap into the three turn indicator wires using supplied tap connectors (reference the wiring diagram).
2. Connect supplied turn indicator wiring harnesses to factory wires using supplied tap connectors; See below for wire color guide.
3. Replace headlights in reverse order of removal.
4. Tap into OEM fog light harness using two supplied tap connectors.
5. Connect supplied fog lamp wiring harness to tap connectors following wire color guide below.
6. Run passenger side fog lamp supply wires across bottom of bumper and tap into Fab Fours driver side fog lamp wires.
7. Install turn indicators into the plastic light insert using three self-tapping screws as shown below:

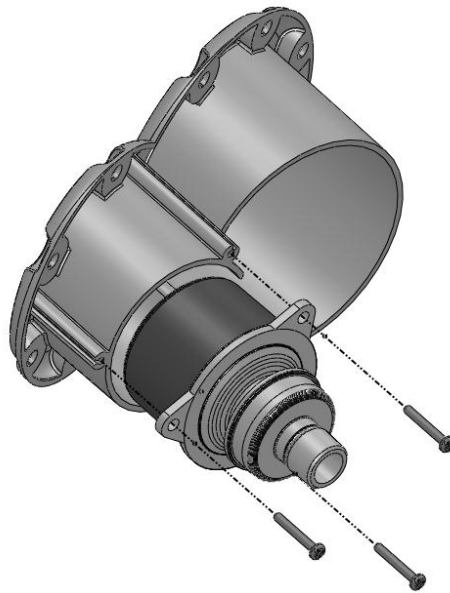

Figure 4 – Turn Signal Installation



Installation Instructions

Dodge Winch Bumper

Product Number: A1050-A1052
Application: '03-'05 Dodge Ram 2500-3500

8. Install the light inserts with turn indicators into the cutout in the bumper. Use the $\frac{3}{4}$ " length $\frac{1}{4}$ " stainless steel button head, $\frac{1}{4}$ " washers and hex nuts to fasten the insert through the holes shown below:

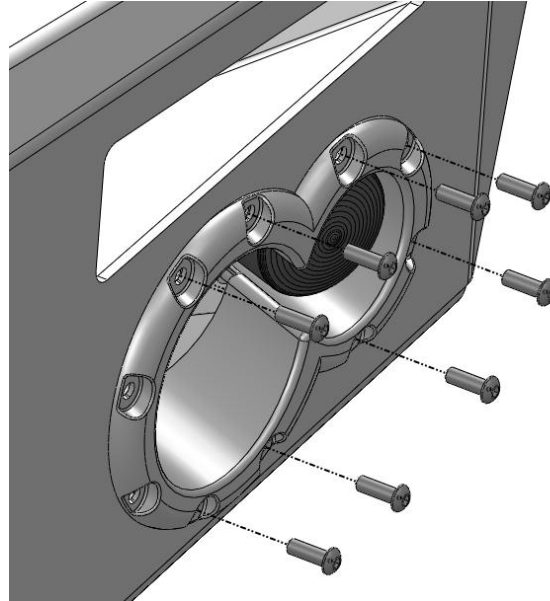

Figure 5 – Light Insert Installation

9. Install the Fab Fours fog lights onto the mounting brackets as shown below using the #8 button head screws, washers, and nylock hex nuts.

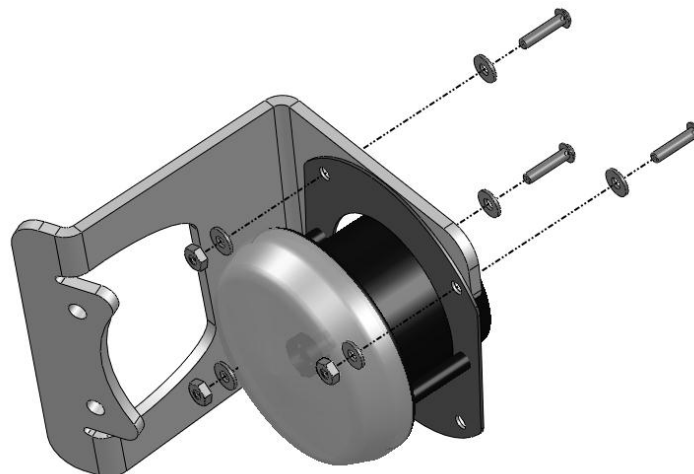

Figure 6 - Fog Light to Bracket Installation



Installation Instructions

Dodge Winch Bumper

Product Number: A1050-A1052
Application: '03-'05 Dodge Ram 2500-3500

10. Install the fog light and bracket into the bumper using the remaining two holes available in the light insert. Use the 1-1/2" length 1/4" stainless steel button heads with 1/4" washers and nylock nuts:

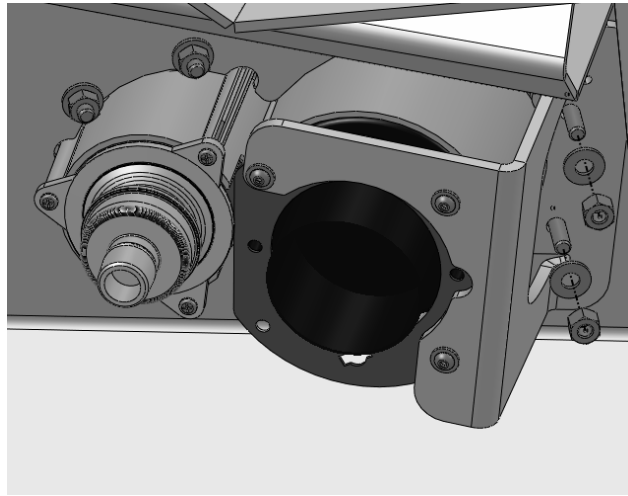
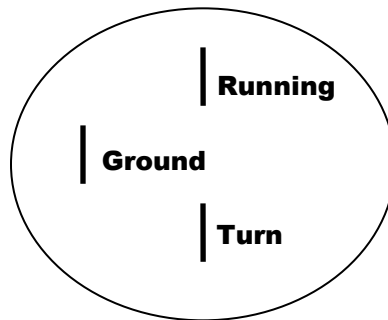

Figure 7 - Fog Light Installation

11. Repeat steps 7-10 for other side.

Do not connect wiring harnesses to lights until bumper is installed.

Turn Indicator Connectors





Installation Instructions
Dodge Winch Bumper
Product Number: A1050-A1052
Application: '03-'05 Dodge Ram 2500-3500

WIRE COLOR CROSS REFERENCE:

Note: Colors may vary – It is best to verify the wires with a multi meter before tapping.

Driver Side Turn Indicator at Headlight

OEM (Running) White/Yellow → White Fab Fours
OEM (Turn) White/Green → Red Fab Fours
OEM (Ground) Black → Green Fab Fours

Passenger Side Turn Indicator at Headlight

OEM (Running) White/Grey → White Fab Fours
OEM (Turn) White/Brown → Red Fab Fours
OEM (Ground) Black/Brown → Green Fab Fours

Fog Lamp

OEM (Power) White/Yellow → Red Fab Fours
OEM (Ground) Black → Green Fab Fours



Installation Instructions

Dodge Winch Bumper

Product Number: A1050-A1052
Application: '03-'05 Dodge Ram 2500-3500

V. Bumper Installation

- **Optional:** If installing winch and roller fairlead into bumper, do it at this time. Follow the winch manufacturer's instructions for installation. If you are installing a winch with a pulling capacity of 12,000 lbs. or greater, the front face mounting holes must be used.

If not installing a winch, a license plate may be installed onto the front face of the bumper using the provided 1/4" hardware.

1. Install intermediate mount onto the frame rail using the OEM bumper stud plates and nuts, and 1/2" x 4.0" bolts, washers, lock washers and nuts provided in the hardware kit as shown below. OEM stud plates do not need to be reinstalled from the inside of the frame. **DO NOT FULLY TIGHTEN**, repeat for other side.



Figure 8 - Intermediate Bracket Installation



Installation Instructions

Dodge Winch Bumper

Product Number: A1050-A1052
Application: '03-'05 Dodge Ram 2500-3500

2. Insert the provided stud plate assemblies through the back of the bumper mount face as shown below.

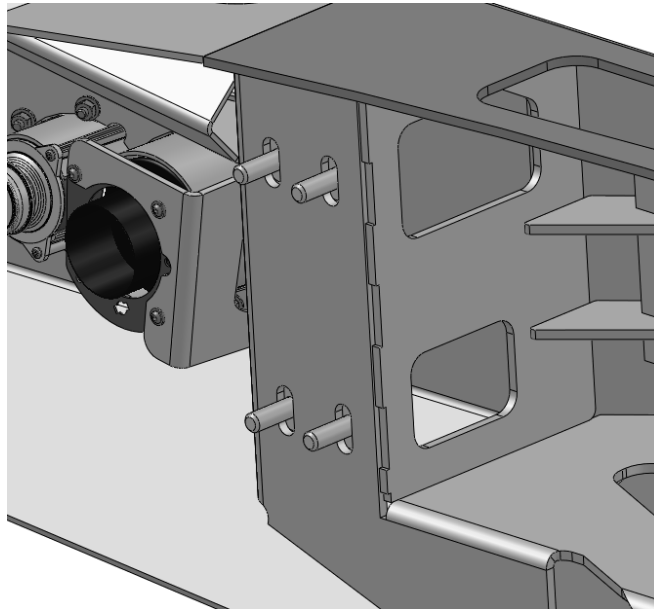

Figure 9 – Stud Plate Orientation

3. Lift the bumper and carefully insert the studs into the slots on the mounting brackets. With the bumper supported, install four nuts, washers, and lock washers per side onto the studs. **DO NOT FULLY TIGHTEN**

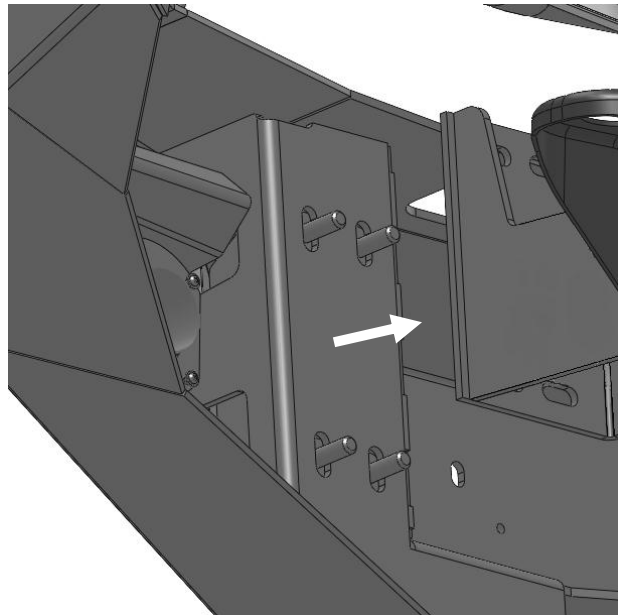

Figure 10 – Bumper Installation



Installation Instructions

Dodge Winch Bumper

Product Number: A1050-A1052
Application: '03-'05 Dodge Ram 2500-3500

4. Adjust the bumper to achieve good visual alignment as follows:
 1. Adjust in/out bumper alignment with mounting bracket to frame hardware.
 2. Adjust up/down and left/right alignment with bumper to mounting bracket hardware
5. Tighten all fasteners fully; beginning with frame mounts. Then tighten all mount-to-bumper fasteners.
6. Connect wiring harnesses to lights as shown in wiring diagram.
7. Verify proper operation of lights. **Note:** Turn indicators should be dim during "running" condition and flash bright for turn.

VI. Maintenance/Care

- Periodically check and tighten all fasteners.
- Stripped, fractured, or bent bolts or nuts need to be replaced.



More than expected... Better than expected