



Installation Instructions

Suburban Rear Bumper

Product Number: W2250

Application: '07-'12 Chevy Suburban

I. Overview

Congratulations on your purchase of the industries' best and most stylish Chevy Suburban Rear Bumper! This bumper has been **engineered** for strength while keeping the weight down.

Your bumper was designed in 3-D, fabricated, and powder coated... all in the U.S.A.

Enjoy the fit and finish of a quality Chevy Suburban Rear Bumper from Fab Fours Inc!

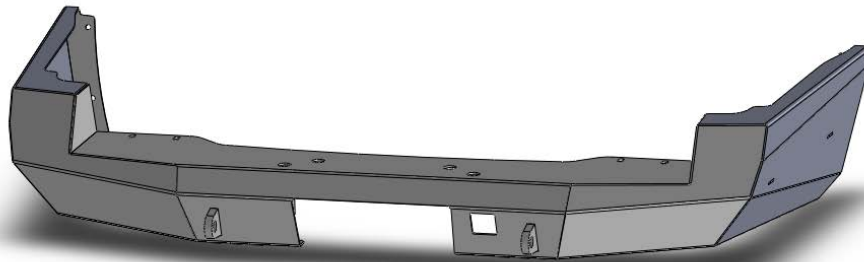

Installation Instructions

Suburban Rear Bumper





Product Number: W2250

Application: '07-'12 Chevy Suburban

II. Tools Required

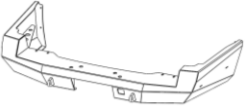
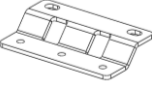
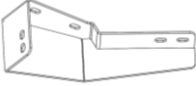
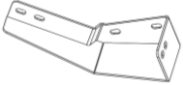
- Socket Wrench With Extensions
- 5/32" Allen Wrench
- 1/8" Allen Wrench
- 3/4" Socket
- 3/8" Socket
- 7/32" Socket
- 7mm Socket
- 10mm Socket
- 18mm Socket
- 3/4" Open End Wrench
- 3/8" Open End Wrench
- Flat Head Screwdriver
- Plastic Rivet removal tool
- Drill with 17/64" bit

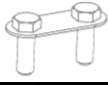
III. Package Contents

	Qty	Description	Fab Fours Part Number
	x 1	HD Rear Bumper	W2250-B
	x 2	Lower Support Bracket	20356
	x 1	Driver Side Outer Bracket	20357
	x 1	Passenger Side Outer Bracket	20358
	x 2	Top Mount Spacer	20360-01
	x 2	Lower Support Spacer	20360-01
	x 2	Stud Plate	20296
	x 1	W2250 Hardware Kit	W2250-HW
	x 1	W2250 Instruction Manual	W2250-IM

Installation Instructions

Suburban Rear Bumper

Product Number: W2250

Application: '07-'12 Chevy Suburban

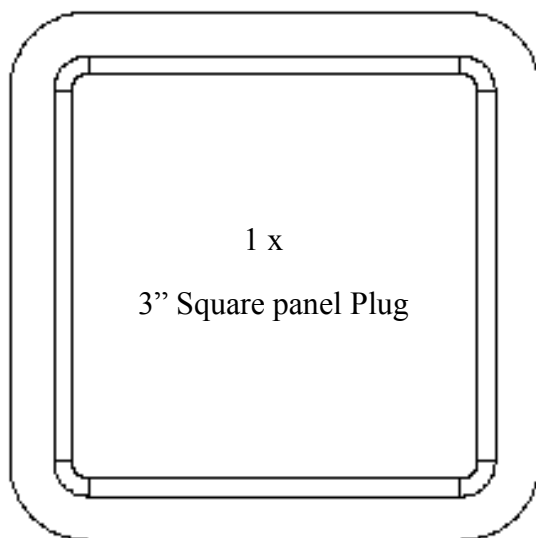
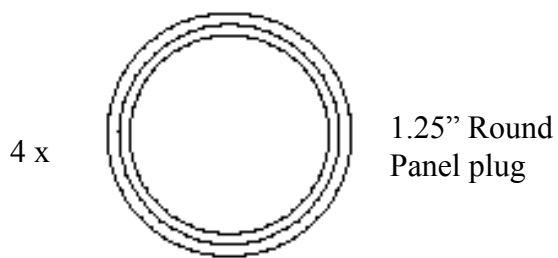
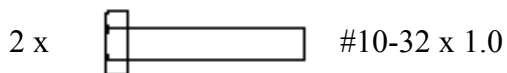
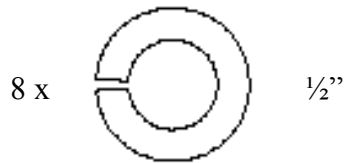
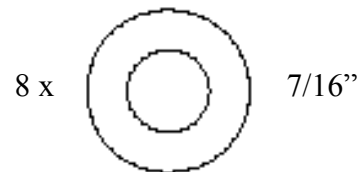
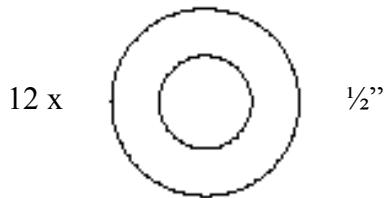
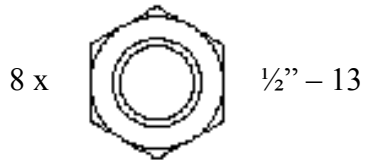
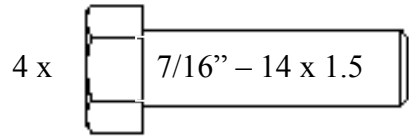
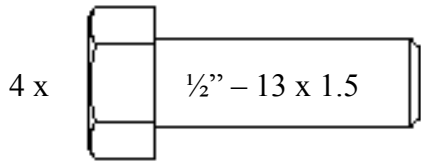

Installation Instructions

Suburban Rear Bumper

Product Number: W2250

Application: '07-'12 Chevy Suburban

IV. Vehicle Preparation

1. Using a small flat head screwdriver, remove the plastic rivet in the lower corner of each rear wheel well by inserting the screwdriver into the recess and prying the head outward. See Figure 1.
2. Using a 7mm socket and ratchet, Remove the two (2) screw fasteners from each wheel attaching the rear bumper cover to the inner fender liner

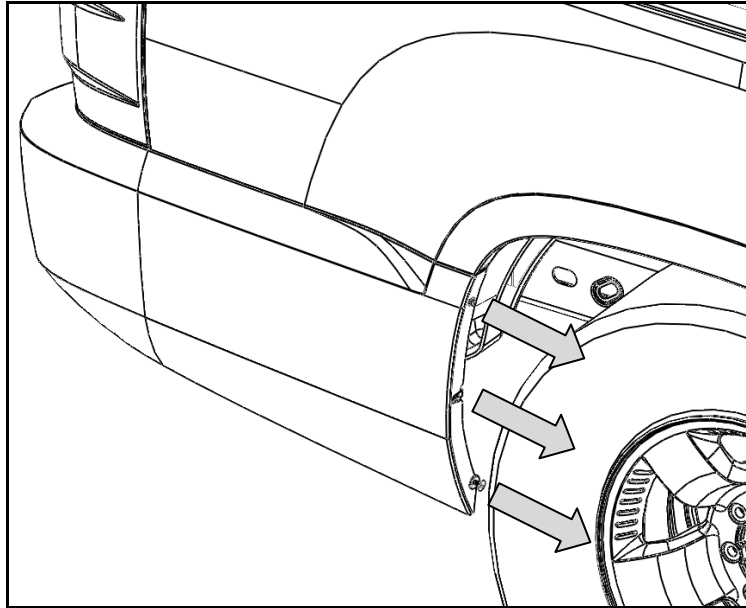

Figure 1 - WHEEL WELL FASTENER LOCATIONS

3. Open the rear lift gate and remove the two plastic push rivets from below the center of the door with a small flat head screwdriver or plastic rivet removal tool.
4. Remove the four (4) remaining screws from the door sill with a 7mm socket and ratchet.

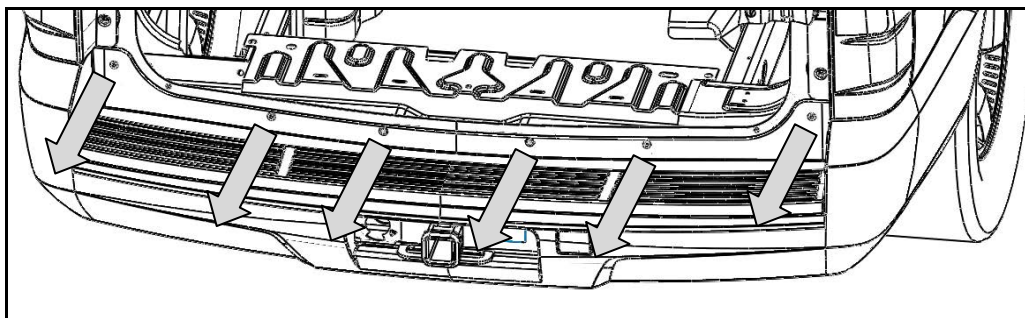

Figure 2 - DOOR SILL FASTENER LOCATION

Installation Instructions

Suburban Rear Bumper

Product Number: W2250

Application: '07-'12 Chevy Suburban

5. Detach the rear bumper cover from the lower support brackets by removing the screw fastener with a 10mm socket and ratchet. See below for fastener location:

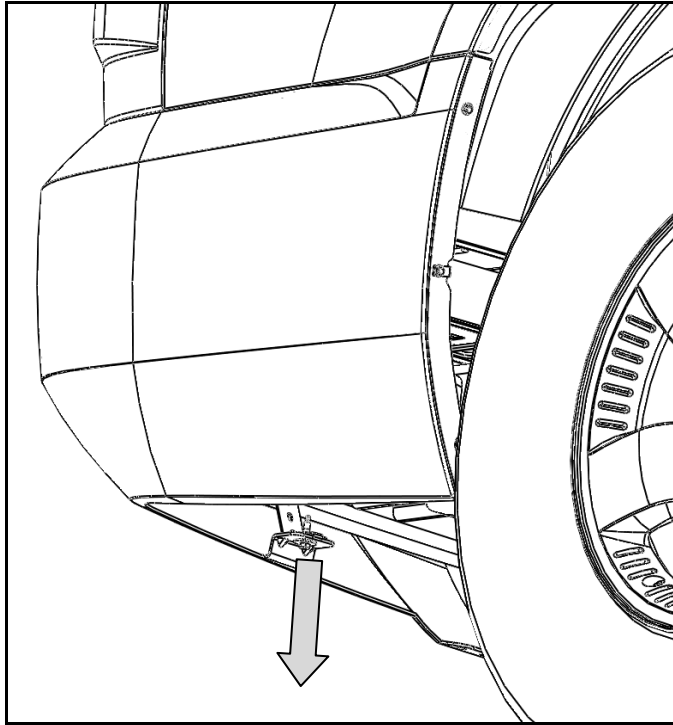

Figure 3 – LOWER SUPPORT FASTENER LOCATION – VIEW FROM BELOW

6. Reaching behind the bumper cover at the outer corner, firmly pull the cover outward to release it from the fastening clips. Repeat for other side

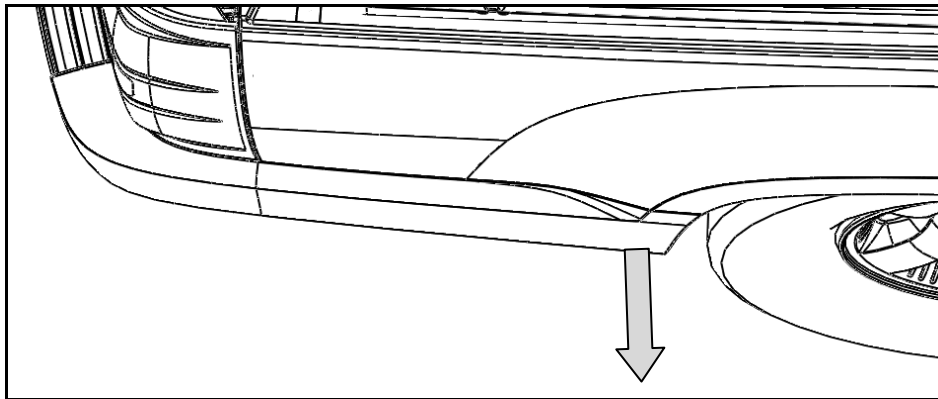

Figure 4 - CORNER CLIP RELEASE

Installation Instructions

Suburban Rear Bumper

Product Number: W2250

Application: '07-'12 Chevy Suburban

7. Pull rearward on the bumper cover to remove it from the truck.

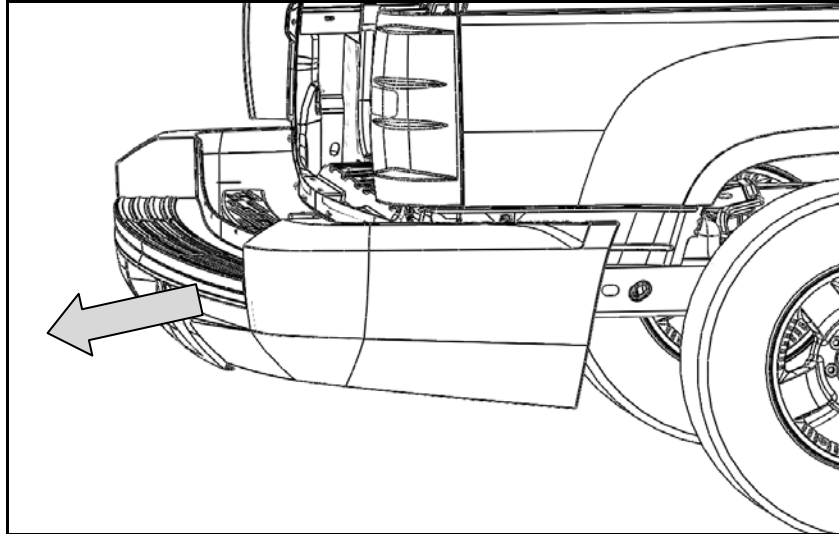

Figure 5 – BUMPER COVER REMOVAL

8. If your vehicle is equipped with Park Assist Radar, the wiring harness must be disconnected passenger side of the bumper before it can be fully removed.
9. Remove three (3) fasteners attaching the the bumper cover clipping brackets to the bottom of the fenders with a 10mm socket. See below for fastener location:

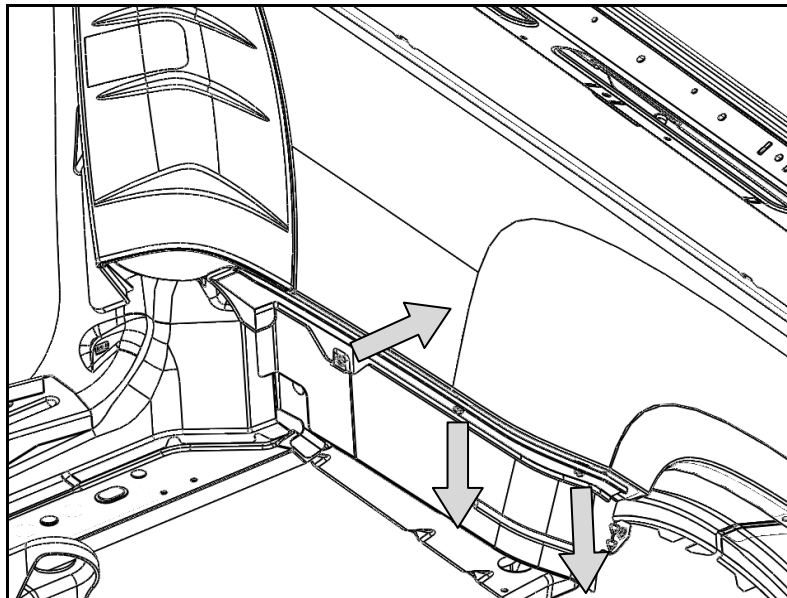

Figure 6 - CLIPPING BRACKET REMOVAL – VIEW FRM BELOW

Installation Instructions

Suburban Rear Bumper

Product Number: W2250

Application: '07-'12 Chevy Suburban

10. The disassembly of the vehicle is now complete.

Optional: Removal of the spare tire will increase accessibility to Fab Fours bumper adjustment points during the installation.

Installation Instructions

Suburban Rear Bumper

Product Number: W2250

Application: '07-'12 Chevy Suburban

V. Bumper Installation

NOTE: The Following Installation steps apply to the installation of your Fab Fours HD Rear Bumper. **PLEASE READ THE ENTIRE MANUAL BEFORE ATEMPTING INSTALLATION!** Ignoring these steps will increase your probability of damaging the vehicle and/or bumper, as well as decreasing the overall quality of the installation!

1. Fully unpack and inspect all of the components included with your Fab Fours HD rear bumper
2. With the help of another person, lift the bumper weldment into position on the vehicle. The bumper will rest on top of the OEM Hitch.

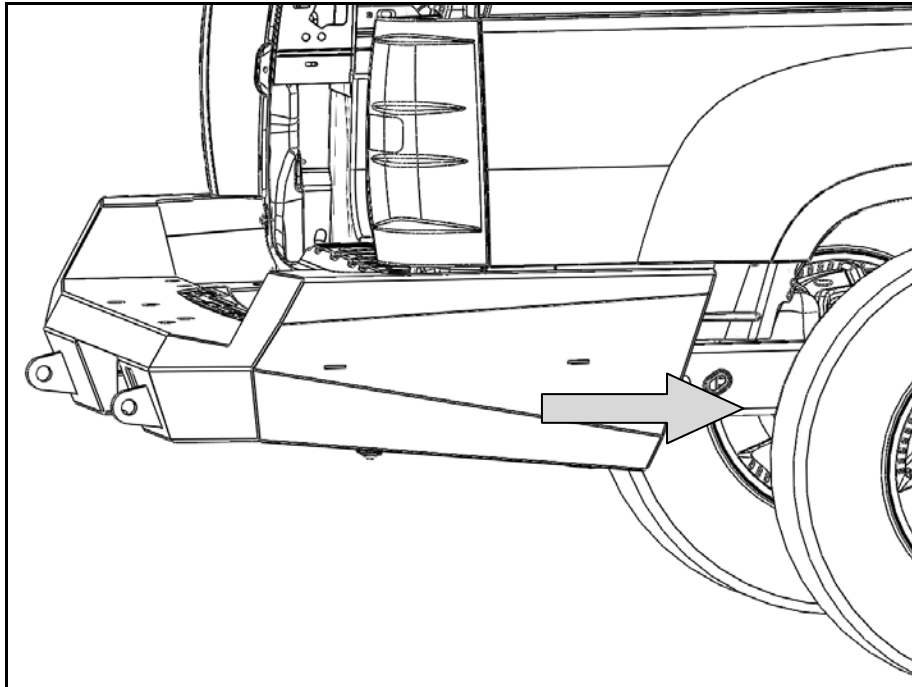

Figure 7 – BUMPER INSTALLATION – SIDE VIEW

Installation Instructions

Suburban Rear Bumper

Product Number: W2250

Application: '07-'12 Chevy Suburban

3. With the bumper being steadied by the installation helper, tilt the bumper forward to allow the body mounting tabs on the fender wells to pass over top of the Fab Fours bumper end caps. With the end cap on the wheel side of the body mounting tab, loosely secure the bumper in place with the OEM fastener. See image below:

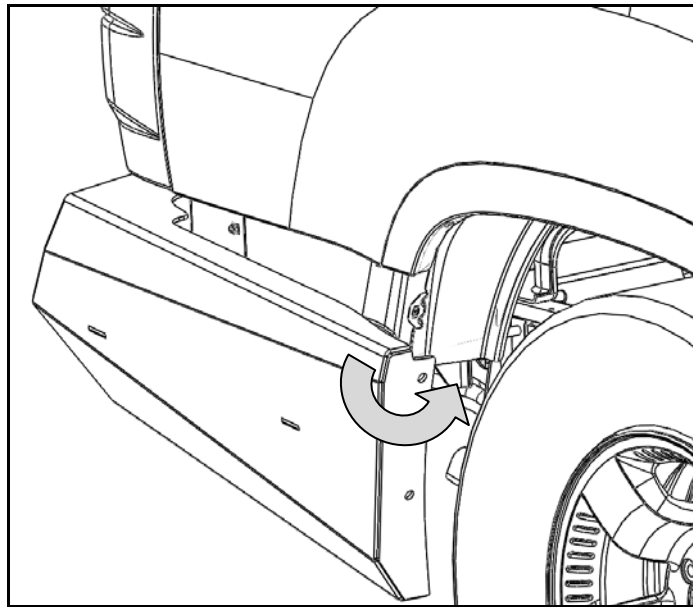

Figure 8 – BODY MOUNTING TAB

4. Check the gap between the fender and the bumper wing. See image below.

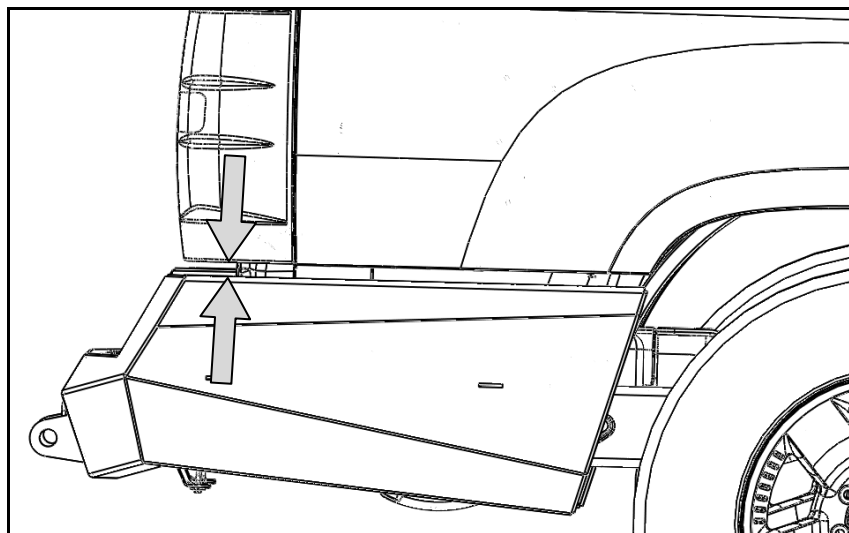

Figure 9 - BUMPER GAP MEASUREMENT

Installation Instructions

Suburban Rear Bumper

Product Number: W2250

Application: '07-'12 Chevy Suburban

5. If the gap at the tail light is larger than $5/8$ " the Fab Fours provided spacer plates can be placed in between the OEM hitch and the bumper mounting plates to reduce the gap. Insert the plates from the back side of the bumper. See image below:

NOTE: If the gap at the taillights is $3/8$ " or less, do not use these spacers to prevent paint or sheet metal damage in normal operation.

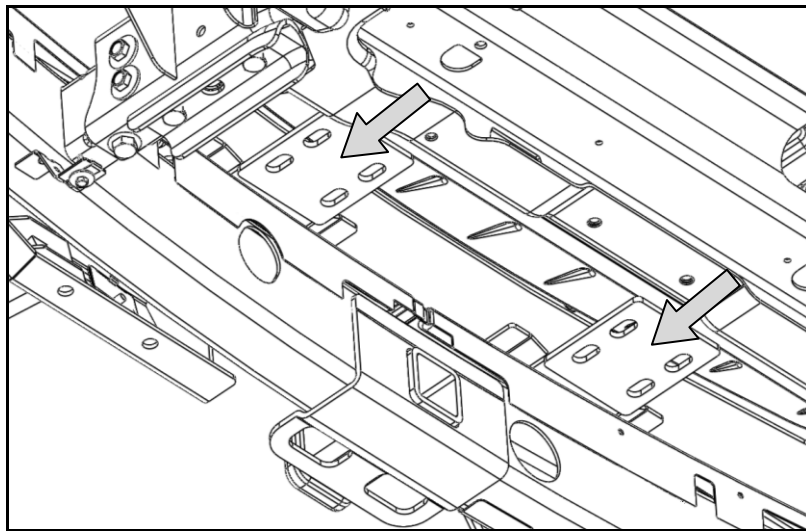

Figure 10 - TOP SPACER INSTALLATION - VIEW FROM BELOW

6. Remove the hitch mounting screws from the side of both frame rails with an 18mm socket and ratchet. These fasteners are installed with Loctite at the factory, so a breaker bar and extra force may be required:

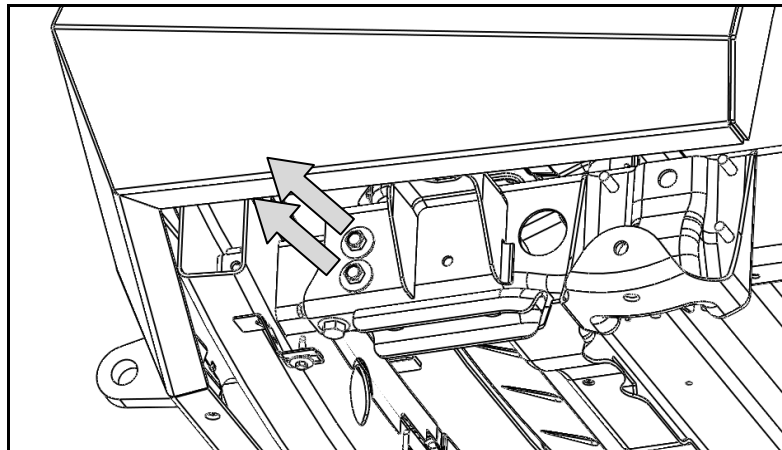

Figure 11 - HITCH MOUNTING SCREW REMOVAL - VIEW FROM BELOW

Installation Instructions

Suburban Rear Bumper

Product Number: W2250

Application: '07-'12 Chevy Suburban

7. Loosely reinstall the hitch mounting screws with the Fab Fours provided bumper mounting brackets as shown below. The outer face of the bumper is removed from the view for clarity:

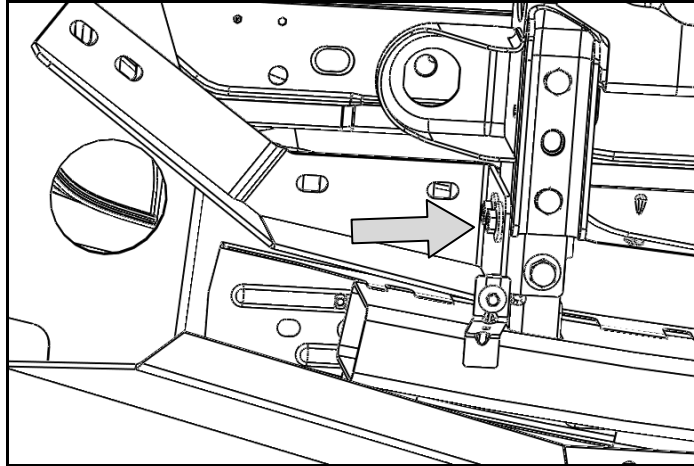

Figure 12 - OUTER BRACKET INSTALLATION - VIEW FROM BELOW PASSENGER FRAME RAIL

8. Loosely install the remaining fasteners for both of the outer brackets.
 - a. The outer holes use the Fab Fours provided stud plates with $\frac{1}{2}$ " flat washers, $\frac{1}{2}$ " lock washers, and $\frac{1}{2}$ " hex nuts. Stud plates should be installed from the top, allowing access to the nuts from below.
 - b. Holes though the top face use $\frac{1}{2}$ " x 1.5" hex bolts with $\frac{1}{2}$ " flat washers, $\frac{1}{2}$ " lock washers, and $\frac{1}{2}$ " hex nuts. Run the bolts down from the top of the bumper to maximize clearance to the lift gate.

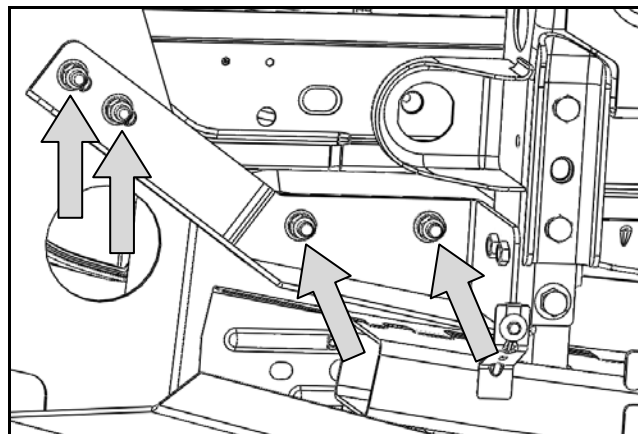

Figure 1 - OUTER BRACKET FASTENER INSTALLATION - VIEW FROM BELOW PASSENGER FRAME RAIL

Installation Instructions

Suburban Rear Bumper

Product Number: W2250

Application: '07-'12 Chevy Suburban

9. Slowly close the lift gate to verify clearance to the bumper and fasteners. With the lift gate closed, center the bumper so the gap on either side is equal.
10. Reopen the lift gate.
11. Install four self-tapping screws into the pre-existing holes in the OEM hitch assembly through the mounting plates accessed through the clearance holes in the top face of the bumper with a 3/8" socket and ratchet:

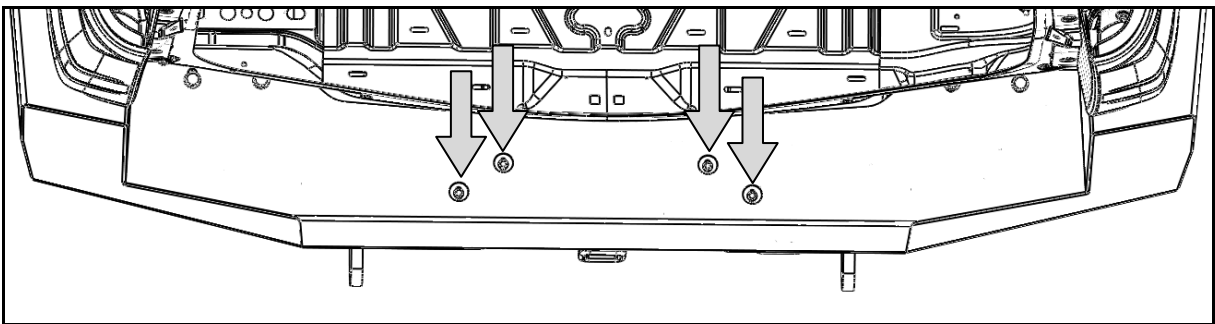

Figure 13 - TOP FASTENER INSTALLATION

12. Verify that the bumper has not shifted during fastening. Re-adjust if necessary, then tighten the outer mounting bracket fasteners, starting with the OEM hitch fasteners (18mm socket and ratchet), then moving to the fasteners through the top face (3/4" socket and ratchet, 3/4" wrench), and tightening the outer fasteners last (3/4" socket and ratchet).
13. Loosely install the Fab Fours provided lower support brackets with provided 7/16" x 1.5" hex bolts, 7/16" flat washers, 7/16" lock washers, and 7/16" hex nuts through the lower edge of the bumper as shown below.

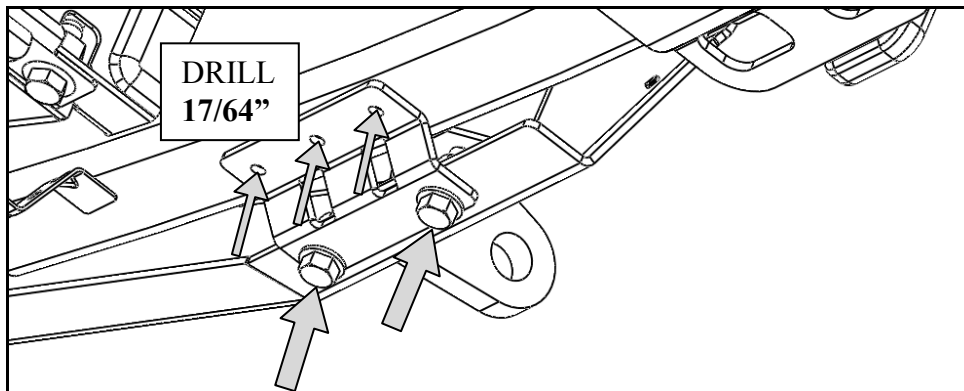

Figure 14 - LOWER SUPPORT BRACKET INSTALLATION - VIEW FROM BELOW

Installation Instructions

Suburban Rear Bumper

Product Number: W2250

Application: '07-'12 Chevy Suburban

14. Drill pilot holes through the three (3) mounting holes into the hitch beam with a 17/64" drill bit. Repeat for both lower support brackets
15. Install three self-tapping screws per bracket into the drilled holes with a 3/8" socket and ratchet.

NOTE: If you did not use the provided spacer to adjust the installation height of the bumper in step 5, then you will need to use the spacer shown in the image below to correct the height of the bracket. If you did use the spacer in step 5, then the spacer is not required for the lower bracket.

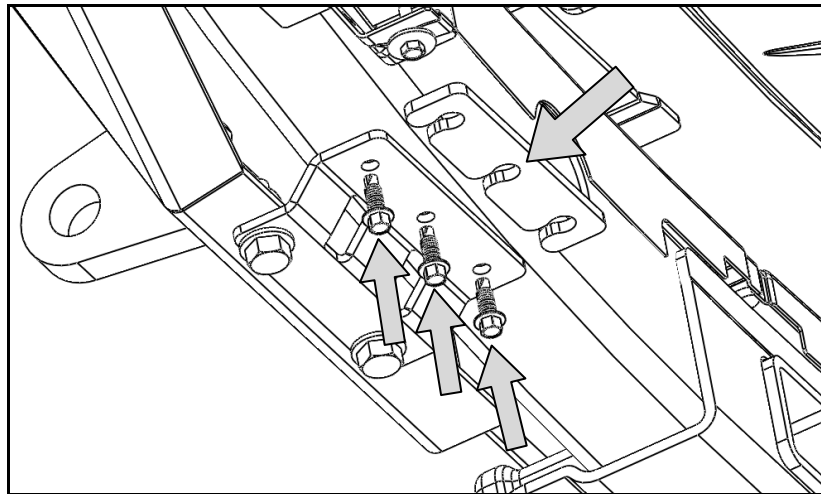

Figure 15 - SELF-TAPPING FASTENER INSTALLATION - VIEW FROM BELOW

16. Fully tighten the 7/16" bolts in the lower edge of the lower edge of the bumper with a 5/8" socket, ratchet, and 11/16" wrench.
17. Install the provided round hole plugs into the access holes to the top fasteners and the provided square hole plug into the spare tire access hole.

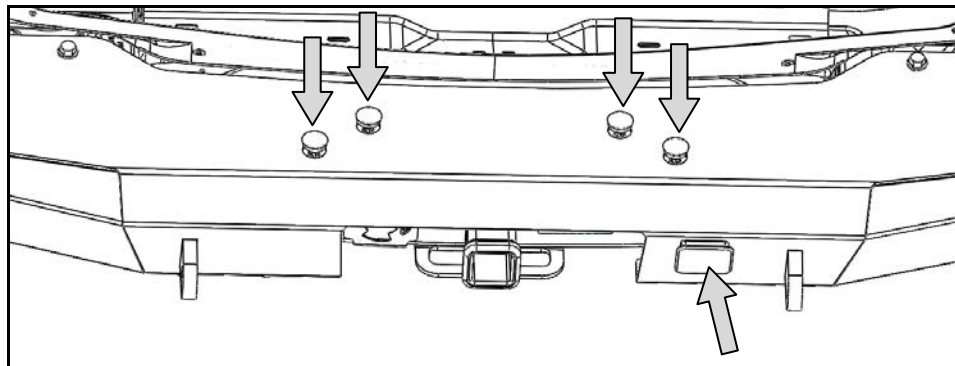

Figure 16 - PANEL PLUG INSTALLATION

Installation Instructions

Suburban Rear Bumper

Product Number: W2250

Application: '07-'12 Chevy Suburban

18. **OPTIONAL:** Trim the inner fender liners to match the higher clearance of your Fab Fours bumper. This can be done with a body saw, rotary tool, or sharp utility knife (New blade strongly recommended). **USE CAUTION WHEN PERFORMING ANY CUTTING OPERATION TO PREVENT VEHICLE DAMAGE OR PERSONAL INJURY.**

19. **OPTIONAL:** Hardware and mounting provisions are provided to reattach the inner fender liner to your Fab Fours bumper if desired. It is recommended that vehicles that perform in severe duty environments or spend a significant amount of time off-highway that the inner fender liner NOT be attached to the Fab Fours bumper, as it may cause damage to the inner fender liner mounting due to chassis flex. For severe duty vehicles, the body mounting screw installed in step 3 should also be removed.

Installation Instructions

Suburban Rear Bumper

Product Number: W2250

Application: '07-'12 Chevy Suburban

VI. Maintenance/Care

- Periodically check and tighten all fasteners.
- Stripped, fractured, or bent bolts or nuts need to be replaced.
- Keep all surfaces free of dirt, road grime, and standing water to ensure finish longevity.



More than expected... Better than expected