

Dynatech[®]

Competition Exhaust Systems

HIGH PERFORMANCE, DRAG RACING, OVAL TRACK RACING

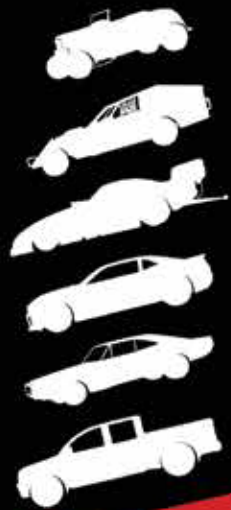

2019

MASTER CATALOG

Dynatech®

WHO WE ARE Dynatech® continues to be the exhaust leader in all forms of racing and high performance applications. Advances in racing, engineering, and design have automakers bringing a whole new breed of cars and trucks to the streets and tracks. This same excitement and new wave of technology is apparent at Dynatech® as you view the pages of our latest catalog. We continue to be focused on new products and award-winning designs.



WORLD CLASS DESIGN & ENGINEERING

Virtual reality exhaust design systems allow engineers to design the exhaust system in virtual space that will meet all necessary design criteria. Key interference and mounting points are captured and then transferred into engineering computer stations. Tube routings, lengths, and diameters can all be manipulated for proper fit and function. These processes cut design time by 90% and produce a much more efficient and powerful design.



TECHNOLOGY & MANUFACTURING

At Dynatech®, we strive for 100% perfection on all of the products that we manufacture. Everything we manufacture goes through proven assembly steps and procedures to provide the end user with a product that we stake our reputation on. We have instituted numerous fitment and quality control inspections. All high performance systems are 100% tested to be leak free and 100% jig tested for fitment.



UNMATCHED SALES & CUSTOMER SERVICE

Our team members are more than welders, machinists, engineers and salespeople. We are racers and enthusiasts just like you. We understand the needs of our customers and respond accordingly with outstanding technical support and customer service. In some cases, the very people that build the product speak with the end user. Fast and friendly service before, during and after the sale all come standard when you purchase Dynatech® products.

CONTENTS

2019 DYNATECH® CATALOG

★★★★★ SUPERIOR PRODUCTS

Dynatech® products provide superior performance and fit for a wide range of exhaust applications. One thing that you can always count on regardless of what Dynatech® product you buy is excellent fit, function and performance. We understand the value of offering no hassle, maintenance-free products to our customers.

5

DRAG RACING

Headers

| | |
|-------------------------------------|----|
| Dragster / Strut Front Headers | 06 |
| Weld-up / Strut Front Header Kits | 09 |
| Camaro / Nova Headers | 10 |
| <i>Standard / Tall Deck Headers</i> | |
| Mustang K-Member Headers | 11 |
| Become a Dealer | 12 |
| Mufflers & Collectors | 13 |
| Exhaust Accessories | 15 |

19

MUSCLE CAR

Headers

| | |
|--------------------------|----|
| '70-'81 Camaro Headers | 21 |
| '67-'69 Camaro Headers | 22 |
| '68-'74 Nova Headers | 24 |
| '68-'72 Chevelle Headers | 26 |
| Block Hugger Headers | 27 |
| Exhaust Accessories | 28 |

30

HIGH PERFORMANCE

Headers

| | |
|---|----|
| '18 Mustang GT | 33 |
| '15-'17 Ford Mustang Shelby GT350 Headers | 34 |
| '11-'17 Ford Mustang 5.0 | 35 |
| '07-'14 Ford Mustang Shelby GT500 Headers | 36 |
| '05-'10 Ford Mustang GT Headers | 37 |
| '05-'17 Challenger / Charger / Magnum Headers | 38 |
| '14-'18 C7 / Z06 Chevy Corvette Headers | 39 |
| '05-'13 C6 / Z06 Chevy Corvette Headers | 40 |
| '97-'04 C5 Chevy Corvette Headers | 41 |
| '09-'15 Cadillac CTS-V Headers | 42 |
| '16-'17 Chevy Camaro SS / ZL1 Headers | 43 |
| '10-'15 Chevy Camaro Headers | 44 |
| '98-'02 Chevy Camaro / Trans Am | 45 |
| Exhaust Accessories | 46 |

49

TRUCK / SUV

Headers

| | |
|---|----|
| '15-'17 Ford F-150 | 52 |
| '11-'14 Ford F-150 | 53 |
| '04-'08 Ford F-150 Truck Headers | 54 |
| '99-'03 Ford F-150 Truck Headers | 55 |
| '99-'04 Ford Lightning / Harley | 55 |
| '14-'18 Chevy / GMC Truck / SUV Headers | 56 |
| '07-'13 Chevy 1500 Truck / SUV Headers | 57 |
| '99-'06 Chevy 1500 Truck / SUV Headers | 58 |
| '00-'09 Hummer H2 Headers | 59 |
| '04-'05 Dodge 1500 Truck Headers | 60 |
| Exhaust Accessories | 61 |

63

OVAL TRACK

Headers

| | |
|-----------------------------|----|
| Crate Modified Headers | 65 |
| Modified Headers | 67 |
| Chevy Street Stock Headers | 69 |
| Dirt Late Model Headers | 71 |
| Pavement Late Model Headers | 73 |

Apparel & More

| | |
|--------------------------------|----|
| AFCO Performance Group Apparel | 74 |
|--------------------------------|----|

FEATURES & BENEFITS

WHAT IS IN A QUALITY SYSTEM?



**CNC LASER-CUT
FLANGES**



**EQUAL LENGTH
PRIMARY TUBES**



**FIBER
GASKETS**



**360° GUSSET
SUPPORTS**

PERFECT, DIRECT BOLT-ON FIT

100% JIG ASSEMBLED AND CHECKED
FOR AN EXCELLENT FIT

OPTIMIZED TUBE LENGTH
FOR INCREASED H.P. AND TORQUE

CERAMIC COATED FINISH

ALL FLANGES



MACHINE SURFACED
AFTER WELDING

MADE IN THE U.S.A.



DRAG RACING

We have taken out all the guess work when it comes to selecting the right header for your race car. Dynatech® Drag Racing Headers are purpose-built to fit your specific application.



TIG-welded flanges are accurate to +/- .003" and improve weld flow for increased durability.

360° Gusset supports increase durability for muffler applications.

All drag headers are Chrome or high-temperature, silver ceramic coated inside and out.

Jig located U-tabs for easy bolt on collector installation.



DRAG RACING

2^{STEP} DRAGSTER **CHROME** HEADERS TWO-STEP VERSION

- Large radius, CNC mandrel bent, equal length primary tubes.
- Equal length for superior acceleration.
- 360° gusset supports increased durability.
- CNC laser-cut flanges for superior quality and accuracy.
- Broader performance range with a combination of two tube sizes.
- A great combination of low end Tq and high end Hp over a non-stepped header.

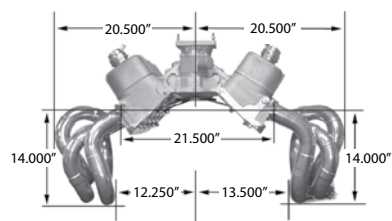

*Pan E-vac/O2 Kit included with all Standard Collectors.
785-10095

1 YEAR LIMITED WARRANTY
MADE IN THE U.S.A.

| APPLICATION | TUBE SIZE | PART # |
|---|-----------------|-----------|
| CHROME DRAGSTER W/ STANDARD 4.500" COLLECTORS (2 STEP)* | 2.250" - 2.375" | 750-96410 |
| CHROME DRAGSTER W/ STANDARD 4.500" COLLECTORS (2 STEP)* | 2.375" - 2.500" | 750-98410 |
| CHROME DRAGSTER W/ 4.500" MERGE COLLECTORS (2 STEP) | 2.250" - 2.375" | 750-97410 |
| CHROME DRAGSTER W/ 4.500" MERGE COLLECTORS (2 STEP) | 2.375" - 2.500" | 750-99410 |



LONG TUBE BIG BLOCK CHEVY SIDE EXIT HEADER KIT

These Long Tube Big Block Chevy Header kits are designed with ease of assembly and performance in mind. The tubes are tack welded together to make it easy to completely assemble or make changes. Collectors are sold separately and come in a variety of sizes in standard or merge style configurations. Optional ceramic coating is available once you assemble your kit. After assembly, the 16 gauge steel construction and CNC laser-cut, surfaced flanges make this a durable header for multiple racing seasons.

- 0.375" thick CNC laser cut and surfaced flanges.
- Stepped tube sizes to optimize torque and horsepower.
- Designed to run out the side fender of a tube chassis door car with a BBC.
- 28.000" primaries.
- **Collectors sold separately (page 14).**



| APPLICATION | TUBE SIZE | PART # |
|---------------------------------|-----------------|-----------|
| SIDE EXIT HEADER KIT | 2.250" - 2.375" | 760-42410 |
| SIDE EXIT HEADER KIT | 2.375" - 2.500" | 760-44410 |
| SIDE EXIT HEADER KIT (14° HEAD) | 2.250" - 2.375" | 760-46410 |
| SIDE EXIT HEADER KIT (14° HEAD) | 2.375" - 2.500" | 760-47410 |



DON O'NEAL

DRAG RACING

HEADERS SLIP-ON COLLECTORS

1 YEAR LIMITED WARRANTY
MADE IN THE U.S.A.

DRAGSTER, BIG BLOCK CHEVY, STRUT FRONT & DOOR SLAMMER

- CNC laser cut flanges feature raised port location for increased power.
- Unique port gussets eliminate cracking caused by tire shake and muffler applications.
- Jig located U-tabs for hassle free, bolt-on collectors.
- Five models in straight or stepped header tubes.
- 28.000" equal length design.
- High-temp., silver ceramic coated inside and out. Ceramic coating comes with a three year limited warranty.



*Pan E-vac/O2 Kit included with all Standard Ceramic Collectors. (Collectors sold separately)

HEADERS ONLY



STANDARD COLLECTOR (COATED)*



| APPLICATION | TUBE SIZE | PART # | PART # / OUTLET SIZE |
|----------------------|-----------------|-----------|----------------------|
| STRUT TYPE, DRAGSTER | 2.250" | 750-91410 | 783-71241 (4.000") |
| | 2.250" - 2.375" | 750-92410 | 783-81241 (4.000") |
| STRUT TYPE, DRAGSTER | 2.375" | 750-93410 | 783-81246 (4.500") |
| | 2.375" - 2.500" | 750-94410 | 783-91246 (4.500") |
| STRUT TYPE, DRAGSTER | 2.500" | 750-95410 | 783-91246 (4.500") |

WELD-UP HEADER KITS

BIG BLOCK CHEVY STRUT FRONT AND DRAGSTER HEADERS

Designed specifically for strut type front end cars and dragsters, this kit allows you to fabricate your own headers to save money or make changes to the kit to fit your specific needs. These kits are assembled in the same jig we use for our finished headers. Then, we simply tack-weld all connections. If needed, you can cut a tack-weld to reposition the tube, or you can simply finish weld the kit and have the same header offered by Dynatech®.

- Same exact header as a Dynatech® finished header.
- Tack-welded to make it easy to change or finish weld.
- CNC laser-cut flanges, gaskets, gussets and bolts included.
- Optimum port exit angle for added power.
- **Collectors must be purchased separately (see below.)**
- **Star Plugs must be purchased separately (see page 14.)**

BIG BLOCK DRAGSTER/STRUT TYPE HEADERS

| TUBE SIZE | HEADER KIT |
|-----------------|------------|
| 2.250" | 760-91410 |
| 2.250" - 2.375" | 760-92410 |
| 2.375" | 760-93410 |
| 2.375" - 2.500" | 760-94410 |
| 2.500" | 760-95410 |

SMALL BLOCK DRAGSTER/STRUT TYPE HEADERS

| TUBE SIZE | HEADER KIT |
|-----------------|------------|
| 1.875" - 2.000" | 762-91510 |



STANDARD COLLECTOR

| TUBE SIZE | OUTLET SIZE | PART# |
|-----------|-------------|-----------|
| 2.000" | 3.500" | 783-51235 |
| 2.250" | 4.000" | 783-71240 |
| 2.375" | 4.500" | 783-81245 |
| 2.500" | 4.500" | 783-91245 |
| 2.500" | 5.000" | 783-91250 |



MERGE COLLECTOR

| TUBE SIZE | OUTLET SIZE | PART# |
|-----------|-------------|-----------|
| 2.000" | 3.500" | 780-00516 |
| 2.250" | 4.000" | 780-02518 |
| 2.375" | 4.500" | 780-03519 |
| 2.500" | 4.500" | 780-03510 |

Note: Does not include O2 bungs. To purchase separately please order: **785-10097** (pg. 17).

SMALL BLOCK

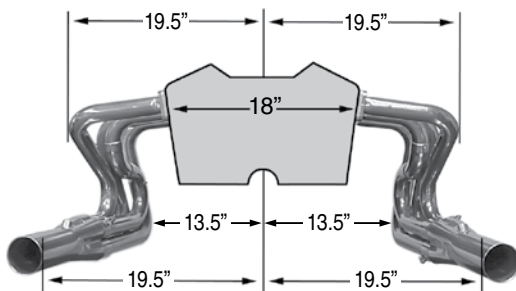

BIG BLOCK

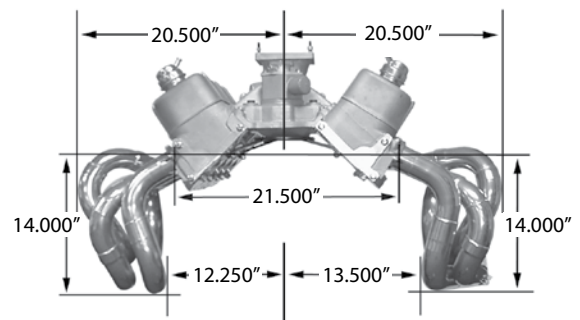

DRAG RACING

DRAG RACING EXHAUST BIG BLOCK CHEVY STD. & TALL DECK "572"

1 YEAR LIMITED WARRANTY
MADE IN THE U.S.A.

'67 – '69 CAMARO
'68 – '74 NOVA

▶ COATED

- Designed for BBC tall deck motors.
- Mandrel bent 2.125" primary tubes.
- CNC laser-cut flanges feature optimum port location for increased power.
- Designed for stock engine location.
- Fits factory, manual, and power steering box.



*Pan E-vac/O2 Kit included with all Standard Coated Collectors.

- High-temp., silver ceramic coated inside and out.
- Ceramic coated headers require separate purchase of collectors.
- 10.200" Deck Height.



STANDARD COLLECTOR (COATED)*

HEADERS ONLY

| APPLICATION | TUBE SIZE | PART # | OUTLET SIZE | PART # |
|----------------------|-----------|-----------|--|-----------|
| BBC GM 572 TALL DECK | 2.125" | 750-91010 | 3.500" | 783-61236 |
| | | | 4.000"  | 783-61241 |

'67 – '69 CAMARO
'68 – '74 NOVA

▶ PAINTED

- Painted headers come with collectors installed.
- Reducer kit included.
- Built for use with the factory subframe.
- Fits around Manual and Power Steering boxes as well as factory A/C boxes and factory power brake booster.
- Fits Automatic or 4 speed.
- Ceramic coating services are available. Call for details.



Black Painted
750-91910 shown

| APPLICATION | TUBE SIZE | PART # | OUTLET SIZE |
|--|-----------|-----------|-------------|
| BBC GM 572 TALL DECK (PAINTED) 10.2" DECK HEIGHT | 2.125" | 750-91910 | 3.500" |
| BBC GM STANDARD DECK (PAINTED) 9.8" DECK HEIGHT | 2.125" | 740-59310 | 3.500" |

MUSTANG K-MEMBER HEADERS '79 - '04 MUSTANGS

- For use with AJE, TEAMZ, and P.A. Racing K Members.
- Fits with factory starter, master cylinder, brake booster & proportioning valve (SBC, SBF, LSX only).
- Designed to be used with a wide variety of transmissions.
- '79-'93 requires after market steering shaft.
- May require a "cable style" shifter linkage.
- Not designed for use with motorplate.



1 YEAR LIMITED WARRANTY
MADE IN THE U.S.A.



LSX

'79 - '93 w/ LS Based Chevy: 1.875" Tube w/ 3.000" Collector

715-91410

'94 - '04 w/ LS Based Chevy: 1.875" Tube w/ 3.000" Collector

715-91310



SBC

SMALL BLOCK CHEVY:

1.750"- 1.875" Tube
3.000" Collector

701-23010



BBC

BIG BLOCK CHEVY:

2.125" Tube
3.500" Collector

750-91110



SBF

351 WINDSOR & 302*:

1.750"- 1.875" Tube
3.000" Collector

704-23010

**Will work with 302 by spacing engine up 0.625" between engine block and motor mount.*



BECOME A DYNATECH® DEALER

INTERESTED IN BECOMING A DYNATECH® DEALER?

Dynatech® is always looking for new dealers to represent our product line.

MUFFLERS

Auger Style Muffler



- 11.000" long – fits inside 3.000" or 3.500" O.D. pipe.
- Weighs only 1.000 lb.
- 6-7 dB reduction.

| APPLICATION | SIZE | PART # |
|---------------------|--------|-----------|
| AUGER STYLE MUFFLER | 3.000" | 776-24302 |
| AUGER STYLE MUFFLER | 3.500" | 776-24352 |

SPLIT-FLOW[®] RACING MUFFLERS

The Split-Flow[®] racing muffler is the "hot topic" among racers, and for good reason. The straight-thru design can handle big power. The exclusive dual pattern core reduces dB levels while maintaining a powerful sound. The all-aluminized, fully welded construction makes it a top choice for racing and high performance applications.

- Straight-thru design for maximum flow.
- Dual-pattern core for reduced sound levels.
- All-aluminized materials and welded construction.
- Stainless steel sound absorbing material for no burnout.
- Lightweight design.
- Meets or exceeds dB requirements at most muffler-required sanctioned events.

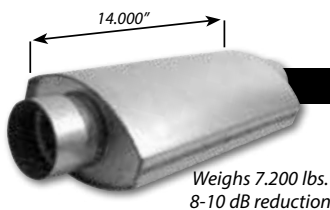
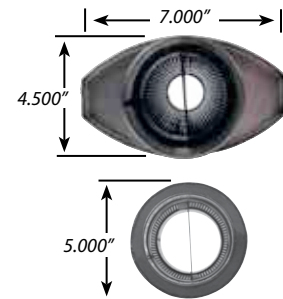

| OVAL (14.000" L X 7.000" W X 4.500" H DIA.) | INLET I.D. | OUTLET I.D. | PART # |
|---|------------|-------------|-----------|
| SPLIT-FLOW [®] OVAL | 2.500" | 2.500" | 776-14252 |
| SPLIT-FLOW [®] OVAL | 3.000" | 3.000" | 776-14302 |
| SPLIT-FLOW [®] OVAL | 3.500" | 3.500" | 776-14352 |

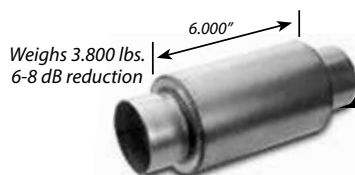

| ROUND (6.000" L X 5.000" DIA.) | INLET I.D. | OUTLET I.D. | PART # |
|--------------------------------|------------|-------------|-----------|
| SPLIT-FLOW [®] ROUND | 3.000" | 3.000" | 776-06302 |
| SPLIT-FLOW [®] ROUND | 3.500" | 3.500" | 776-06352 |

DRAG RACING

STANDARD COLLECTORS

Dynatech® slip-on race collectors offer great performance at an affordable price. All collectors come race-ready right out of the box. They are available in a wide variety of primary tube and collector outlet sizes for all popular applications.

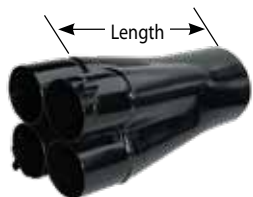

PAINTED MILD STEEL SLIP-ON COLLECTORS

| TUBE SIZE | OUTLET SIZE | LENGTH | PART# |
|-----------|-------------|---------|-----------|
| 1.750" | 3.000" | 12.000" | 783-31230 |
| 1.875" | 3.000" | 12.000" | 783-41230 |
| 1.875" | 3.500" | 12.000" | 783-41235 |
| 2.000" | 3.500" | 12.000" | 783-51235 |
| 2.125" | 3.500" | 12.000" | 783-61235 |
| 2.125" | 4.000" | 12.000" | 783-61240 |
| 2.250" | 4.000" | 12.000" | 783-71240 |
| 2.375" | 4.500" | 12.000" | 783-81245 |
| 2.500" | 4.500" | 12.000" | 783-91245 |
| 2.500" | 5.000" | 12.000" | 783-91250 |



CERAMIC COATED MILD STEEL SLIP-ON COLLECTORS

| TUBE SIZE | OUTLET SIZE | LENGTH | PART# |
|-----------|-------------|---------|-----------|
| 2.125" | 3.500" | 12.000" | 783-61236 |
| 2.125" | 4.000" | 12.000" | 783-61241 |
| 2.250" | 4.000" | 12.000" | 783-71241 |
| 2.375" | 4.000" | 12.000" | 783-81241 |
| 2.375" | 4.500" | 12.000" | 783-81246 |
| 2.375" | 5.000" | 12.000" | 783-81251 |
| 2.500" | 4.500" | 12.000" | 783-91246 |



*Pan E-vac/O2 Kit included with all Standard Collectors.



Required when using non-slip-on/weld-on collectors.



STAR PLUGS

| TUBE SIZE | PART# |
|---------------------------------|-----------|
| SMALL UP TO 1.875" TUBE SIZE | 794-00002 |
| SMALL UP TO 2.250" TUBE SIZE | 794-00012 |
| X-LARGE 2.375" TUBE SIZE AND UP | 794-00022 |



Collector Spike/Goilet

| Collector Spike | PART# |
|-----------------|-----------|
| Collector Spike | 550000620 |

MERGE COLLECTORS

In order to understand how the merge collector works, you must first know why one exhaust system can generate more torque and horsepower than another. The ability of a header/exhaust system to maintain exhaust gas velocity has a tremendous impact on realizing maximum torque and horsepower. Any significant changes in the system, such as baffles (mufflers) or collectors, will have an impact on exhaust gas velocity. The large area change seen at the transition from the primary tube to the collector causes an immediate reduction in exhaust gas speed. This reduction in speed decreases the efficiency of the system, thereby reducing scavenging ability. Scavenging ability is the key factor by which an exhaust system is evaluated. The more efficient the system, the more air/fuel mixture that can be pulled into the combustion chamber. Obviously, the greater quantity of air/fuel mixture that can be burned, the more torque and power potential the engine has.

The construction of a merge collector is such that the change in area at the primary tube to collector transition point is minimized. This gradual transition allows the exhaust gas to maintain as much velocity as possible. Maintaining gas velocity is the key to allowing the exhaust system to reach its efficiency potential.

Merge collectors significantly improve the efficiency of the exhaust system. If your combination has been optimized to a header with standard collectors, it's possible to over-scavenge when adding merge collectors. Over-scavenging will normally decrease torque and horsepower when compared to your optimized, previous setup. We recommend dyno testing to arrive at the final camshaft combination when using this style of collector. If you need that last little edge and are willing to do the testing required to realize the potential gains, merge collectors are one of the most economical ways to gain significant amounts of torque and horsepower in the entire engine combination.

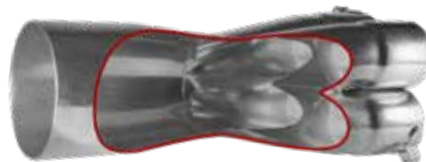

- 100% TIG-welded.
- Optimum reduction angle.
- Increases torque and horsepower.
- Sold Individually.

Note: Does not include O2 bungs. To purchase separately please order: **785-10097** (pg. 17).

Mild Steel Merge Collectors

| SLIP OVER | OUTLET | PART # |
|-----------|--------|------------------|
| 2.000" | 3.500" | 780-00516 |
| 2.250" | 4.000" | 780-02518 |
| 2.375" | 4.500" | 780-03519 |
| 2.500" | 4.500" | 780-03510 |

INSERT CONES

VORTEX® INSERT CONE



- 100% T-304 stainless steel construction.
- Ultra-lightweight, less than .500 lbs. each.
- Little or no power loss.
- Easy bolt-in installation.

| TUBE SIZE | A | B | PART # |
|-----------|--------|--------|------------------|
| 3.000" | 3.750" | 1.000" | 772-32520 |
| 3.500" | 4.750" | 1.000" | 772-32510 |
| 4.000" | 6.250" | 1.000" | 772-32530 |
| 4.500" | 6.750" | 1.000" | 772-32540 |

Weights less than 1/2 lbs. 1-3 dB reduction.

HOW IT WORKS:

The Vortex® Insert Cone, installed near the exit of the header collector or muffler outlet, provides a large friction area to reflect and dissipate sound energy, thus reducing the dB level. The open area of the cone is actually greater than the area of the collector or exhaust pipe, thus reducing a back pressure condition. Because no significant back pressure has been introduced, the engine is still able to use the scavenge ability of a good header to create horsepower and torque. Dyno and track testing show significant noise reduction with little or no power loss.

TURN DOWNS WITH CONES

The Vortex® Turn Down is expanded to slip over collector outlets or tail pipes. Greater sound reduction can be achieved by directing the outlet away from the meter or sound test point. U-tab mounting hardware is included.



| DESCRIPTION | TUBE SIZE | PART # |
|--------------------------------------|-----------|------------------|
| TURN DOWN WITH 3.000" CONE INSTALLED | 3.000" | 780-01100 |
| TURN DOWN WITH 3.500" CONE INSTALLED | 3.500" | 780-01200 |

CONES ARE SOLD INDIVIDUALLY, TWO REQUIRED PER V-8 ENGINE.

ACCESSORIES

FLANGES & GASKETS

MUSCLE CAR APPLICATIONS

A great exhaust system starts at the beginning — the flange. One of Dynatech®'s biggest advantages is our wide selection of port matched flanges. All of our flanges are CNC laser cut for unparalleled quality and fit.



Mild Steel Flanges



Fiber Gasket

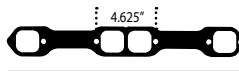
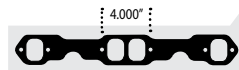

DESCRIPTION

- SMALL BLOCK CHEVY 23°
- SMALL BLOCK CHEVY 23°
- SMALL BLOCK CHEVY 23°
- SMALL BLOCK CHEVY 23°
- SMALL BLOCK CHEVY 18°
- LS1 GM
- STAHL ROUND PATTERN
- SPREAD PORT CHEVY
- SPREAD PORT CHEVY
- SPREAD PORT CHEVY
- BIG BLOCK CHEVY
- BIG BLOCK CHEVY
- BIG BLOCK CHEVY
- BIG BLOCK CHEVY

FLANGE (single)

PORT X Y THICKNESS

GASKET (pair)

| | | | | | |
|-----------|--------|--------|--------|--------|-----------|
| 796-00613 | 1.750" | 1.485" | 1.880" | .375" | 794-00001 |
| 796-00622 | 1.625" | 1.485" | 1.685" | .375" | 794-00001 |
| 796-00022 | 1.625" | 1.485" | 1.685" | .250" | 794-00001 |
| 796-00013 | 1.750" | 1.485" | 1.880" | .250" | 794-00001 |
| 796-00564 | 1.875" | 1.839" | 1.697" | .3125" | 794-03001 |
| 796-60514 | 1.875" | 1.946" | 1.946" | .3125" | 794-20001 |
| 796-01514 | 1.875" | 1.944" | 1.944" | .3125" | - |
| 796-00534 | 1.875" | 1.950" | 1.950" | .3125" | 794-00000 |
| 796-00535 | 2.000" | 2.070" | 2.070" | .3125" | 794-00000 |
| 796-00536 | 2.125" | 2.196" | 2.196" | .3125" | 794-00000 |
| 796-31536 | 2.125" | 2.224" | 2.224" | .3125" | 794-50011 |
| 796-21637 | 2.250" | 2.350" | 2.350" | .375" | 794-50001 |
| 796-21638 | 2.375" | 2.476" | 2.476" | .375" | 794-50001 |
| 796-21639 | 2.500" | 2.600" | 2.600" | .375" | 794-50001 |

CERAMIC COATING

All headers purchased with this option are coated inside and outside. The coating will significantly reduce the underhood temperature of your car — which translates into horsepower gain. **Headers purchased with this ceramic coating come with a 3 year warranty and a customer satisfaction guarantee.**

DESCRIPTION

PART#

| | |
|---------------------------------|-----------|
| CERAMIC COATING FOR HEADERS | 790-00100 |
| CERAMIC COATING FOR X & Y PIPES | 790-00101 |
| CERAMIC COATING FOR ELBOWS | 790-00102 |
| CERAMIC COATING FOR COLLECTORS | 790-00103 |

Note: Ceramic coating not available for Catalytic converters.

ACCESSORIES

CLAMP COLLAR KIT



These clamp collar kits allow you to connect extension pipes, Y-pipes, X-pipes, and mufflers without welding. The clamps also allow you to quickly disconnect if needed.

| DESCRIPTION | TUBE SIZE | PART# |
|------------------|-----------|-----------|
| CLAMP COLLAR KIT | 2.500" | 794-90250 |
| CLAMP COLLAR KIT | 3.000" | 794-90200 |
| CLAMP COLLAR KIT | 3.500" | 794-90350 |
| CLAMP COLLAR KIT | 4.000" | 794-90400 |

O2/PAN E-VAC KIT

Complete kit w/ weld-on bung.

- Increase horsepower.
- Better ring seal.
- Reduce crankcase pressure.



This kit has been dyno-proven to pull as much as 3 inches of vacuum on your typical bracket engine. The U-weld kit features an 18mm threaded bung that will also accept a standard O2 sensor found on EFI applications. Threaded adapter has standard .500" mpt for typical valve cover plumbing installation. 1-kit required per collector.

| DESCRIPTION | PART# |
|----------------------------------|-----------|
| O2 SENSOR/PAN E-VAC COMPLETE KIT | 785-10095 |
| 18MM WELD ON BUNG | 785-10097 |
| O2/E-VAC MALE ADAPTER | 785-10096 |
| 18MM PLUG | 785-10094 |
| 18MM SEALING WASHER | 785-10093 |

V-CLAMP KITS



Kit includes two weld-on v-clamp rings and stainless steel v-band clamp. Models for 2.500", 3.000", or 3.500" pipe sizes.

| DESCRIPTION | PART# |
|--------------------------------|-----------|
| V-CLAMP COLLAR ASSEMBLY 2.500" | 794-91225 |
| V-CLAMP COLLAR ASSEMBLY 3.000" | 794-91230 |
| V-CLAMP COLLAR ASSEMBLY 3.500" | 794-91235 |

HEADER BOLT KITS

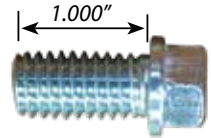

| DESCRIPTION | THREAD | PART# |
|---------------------|--------|-----------|
| 12 POINT HEAD | 3/8-16 | 794-00120 |
| HEX BOLTS (16 PACK) | 3/8-16 | 794-00118 |

MANDREL BENT J-BENDS

Dynatech® stocks a complete inventory of mandrel bent J-bends. These are made from premium grade mild steel tubing.

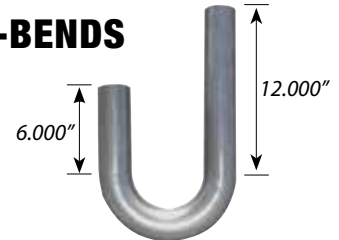

| SIZE | CLR | MILD STEEL PART# | PRICE | STAINLESS PART# |
|--------|--------|------------------|-------|-----------------|
| 1.625" | 2.625" | 794-60202 | | 794-60302 |
| 1.750" | 2.625" | 794-60203 | | - |
| 1.875" | 2.813" | 794-60204 | | 794-60304 |
| 2.000" | 3.000" | 794-60205 | | 794-60305 |
| 2.125" | 3.188" | 794-60206 | | - |
| 2.250" | 3.375" | 794-60207 | | - |
| 2.325" | 3.563" | 794-60208 | | - |
| 2.500" | 3.750" | 794-60209 | | 794-60309 |

U-TAB KIT



These are the same U-tabs we use on all Dynatech® headers and collectors. Kit includes: U-tabs and hardware.

| DESCRIPTION | PART# |
|-----------------------------|-----------|
| U-TAB KIT (2 TABS, 1 BOLT) | 794-00310 |
| U-TAB KIT (4 TABS, 2 BOLTS) | 794-00313 |
| U-TAB KIT (8 TABS, 4 BOLTS) | 794-00320 |

EXTENSIONS

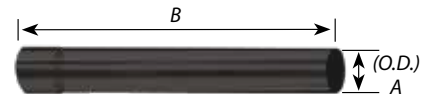

- Manufactured from mild steel.
- Designed to slip over 3.000" or 3.500" outer diameter on one end.
- Ideal for finishing your exhaust system.

| "A" | "B" | PART# |
|--------|---------|-----------|
| 3.000" | 48.000" | 780-00250 |
| 3.500" | 48.000" | 780-00300 |
| 3.500" | 24.000" | 780-00301 |
| 3.000" | 24.000" | 780-00302 |

ACCESSORIES

EXHAUST ELBOWS

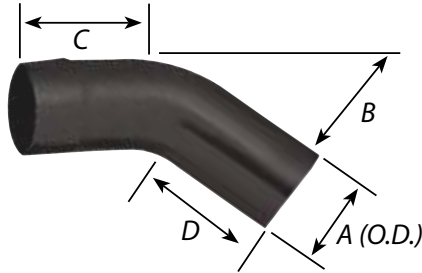

| "A" | "B" | "C" | "D" | PART# |
|--------|-----|--------|---------|-----------|
| 3.000" | 30° | 6.000" | 6.000" | 780-30301 |
| 3.500" | 30° | 6.000" | 7.000" | 780-30351 |
| 3.000" | 42° | 6.000" | 12.000" | 780-42301 |
| 3.500" | 42° | 6.000" | 12.000" | 780-42351 |
| 3.500" | 60° | 6.000" | 6.000" | 780-60351 |
| 3.500" | 70° | 6.000" | 6.000" | 780-70351 |
| 3.000" | 80° | 2.000" | 5.875" | 780-80301 |
| 3.500" | 80° | 2.000" | 5.750" | 780-80351 |

STEPPED BAND CLAMPS

Smooth transition taper allows proper fit to seal expanded slip-fit connections. Great for muffler/tail pipe connections.



| DESCRIPTION | PART# |
|--------------------------------|-----------|
| BAND CLAMP FOR 2.500" JUNCTION | 789-70250 |
| BAND CLAMP FOR 2.750" JUNCTION | 789-70275 |
| BAND CLAMP FOR 3.000" JUNCTION | 789-70300 |
| BAND CLAMP FOR 3.500" JUNCTION | 789-70350 |

Models for 2.500", 2.750" 3.000" or 3.500" pipe sizes. 1 clamp/pkg.

EXHAUST TIPS

With their unique insert design, TQ Tips® allow for a flush fit with the outside diameter of your exhaust's tail pipe. This makes for a smooth, clean look that doesn't take away from your car's appearance like bulky, clamped-on tips tend to do. Another quality feature of these tips is the billet aluminum construction, giving them unmatched strength and function.



| DESCRIPTION | PART# |
|---------------------------------------|-----------|
| TQ TIP FOR 2.500" OUTLET (SINGLE TIP) | 794-93025 |
| TQ TIP FOR 3.000" OUTLET (SINGLE TIP) | 794-93030 |
| TQ TIP FOR 2.500" OUTLET (2 PACK) | 794-93026 |
| TQ TIP FOR 3.000" OUTLET (2 PACK) | 794-93031 |

TURNDOWNS

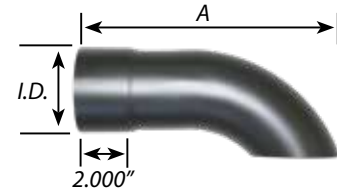

| INNER DIAMETER | A | PART# |
|----------------|---------|-----------|
| 3.000" | 10.000" | 780-00100 |
| 3.500" | 10.000" | 780-00200 |
| 4.000" | 11.000" | 780-00050 |

ADAPTER PLATE KIT



| DESCRIPTION | OPENING SIZE | PART# |
|--|-----------------|-----------|
| SBC STD. 23° TO STAHL PATTERN (0.625" THICK) | 1.125" X 1.125" | 796-00100 |

Includes plates and hardware for both heads.

Designed to be machined to size, to port match Head port.



MUSCLE CAR



.375" thick, laser-cut, surfaced flanges for an excellent seal.

Unique port design accommodates Std. 23 Degree Chevy, "D" Port, and many other Std. Chevy Bolt pattern heads (aluminum and cast iron).

Long tube headers for maximum torque and horsepower across the power range.

Clears 600 Series and all factory steering boxes, power and manual styles.

Ceramic Coating INSIDE AND OUT with a three year warranty on the coating.



- *Designed with excellent ground clearance in mind, when using standard Small Block Chevy Engine Mounts and Factory Front Subframe.*
- *Using Big Block Engine Mounts / Stands and Aftermarket Subframes typically set the engine lower which will result in ground clearance issues.*
- *LSX Conversion Models must use specified mounts described in the installation manual.*
- *Available in multiple sizes, depending on application.*

Unique "Ball & Socket" designed reducer cones, included with every set.

FEATURES & BENEFITS

WHAT IS IN A QUALITY SYSTEM?



*0.375" THICK
CNC LASER-CUT
FLANGES*



*4-BOLT BALL &
SOCKET COLLECTOR
FLANGES*



*FIBER
GASKETS*



*3.000" WIDE / 2-BOLT
BAND CLAMPS*

PERFECT, DIRECT BOLT-ON FIT

100% *JIG ASSEMBLED AND CHECKED
FOR AN EXCELLENT FIT*

OPTIMIZED TUBE LENGTH
FOR INCREASED H.P. AND TORQUE

CERAMIC COATED FINISH

ALL FLANGES



*MACHINE SURFACED
AFTER WELDING*

MADE IN THE U.S.A.

MUSCLEMAXX[®]

'70-'81 CAMARO

CERAMIC COATED HEADERS

▶ FITS: LSX / SBC

1 YEAR LIMITED WARRANTY

MADE IN THE U.S.A.

- 0.375" thick, laser-cut flanges to provide the ultimate leak-free seal.
- SBC flanges specifically designed to fit: 23 deg. standard port, D-port, Fast Burn, LT1 and crate engines.
- Comes in high-temp. silver ceramic coating inside and out.
- CNC laser-cut flanges feature raised port location for increased power.
- Race-proven stepped tube design for maximum street/strip performance.
- Includes bolts and gaskets.
- Direct bolt-on fit.
- 794-03006 Bracket Set is needed for all MuscleMAXX[®] Camaro & Chevelle headers for factory air compressor mounting.



CERAMIC COATED



Reducer cone kit included w/ all headers.



Headers not included with exhaust kit.



HEADER TUBE SIZE

1.625" - 1.750" X 3.000" (SBC)

1.750" - 1.875" X 3.000" (SBC)

*1.875" X 3.000" (LS SERIES)

2.500" REDUCER

740-19210

740-19310

715-19410

3.000" REDUCER

740-29210

740-29310

715-29410

Transmission Cross member: Stock OEM Subframe: OEM Factory Original GM
 * Aftermarket plug wires required for fuel injected applications.
 * Engine Mounts: Speedway Motors part# 910-18012 (DO NOT use Big Block Chevy engine mount brackets. They are approximately .250" narrower and will lower the engine, causing ground clearance issues.)
 Use 916-7081 Kit, or 910-18012 Mount & 910-18016 LS Adapt Plates.

MUSCLE CAR

MUSCLEMAXX®

'67 - '69 CAMARO

STAINLESS STEEL, CERAMIC COATED & PAINTED HEADERS

► FITS: **LSX** / SBC / BBC

1 YEAR LIMITED WARRANTY

MADE IN THE U.S.A.

- 0.375" thick, laser-cut flanges to provide the ultimate leak-free seal.
- SBC flanges specifically designed to fit: 23 deg. standard port, D-port, Fast Burn, LT1 and crate engines.
- CNC laser-cut flanges feature raised port location for increased power.
- BBC headers come painted standard **ceramic coating is optional.**
- LSX & SBC headers comes in high-temp, silver ceramic coating inside and out.
- Race-proven stepped tube design for maximum street/strip performance.
- New design clears the following steering boxes: 600, 700, 800 & factory manual/power with 23° aluminum/factory heads/straight or angle plugs.
- Includes bolts and gaskets.
- Direct bolt-on fit.
- 794-03006 Bracket Set is needed for all MuscleMAXX® Camaro & Chevelle headers for factory air compressor mounting.



STAINLESS STEEL



MUSCLE CAR

CERAMIC COATED



BLACK PAINTED



Headers not included with exhaust kit.



Reducer cone kit included w/ all headers.

HEADER TUBE SIZE

| HEADER TUBE SIZE | 2.500" REDUCER | 3.000" REDUCER |
|-----------------------------------|----------------|----------------|
| *1.875" (LS SERIES) | 715-11410** | 715-21410 |
| 2.125"- 3.500" (BBC STD) PAINTED | - | 740-59310 |
| 2.125"- 3.500" (BBC TALL) PAINTED | - | 750-91910 |
| 1.875" STAINLESS (LS SERIES) | 715-31425*** | 715-31430*** |

EXHAUST SYSTEM

| | | |
|--------------------|---|--------------|
| EXHAUST KIT 3.000" | - | ***793-91130 |
|--------------------|---|--------------|

*** Designed around: Muscle Rods Engine Mount Kit #106-1302-00, Detroit Speed Engine Mount Kit #DSE-060401, Muscle Rods Sure Fit Crossmember Kit #106-2200-00, 4LS0E transmission, factory AC, power brakes, and factory subframe. Steering boxes 600 series/factory manual/power will clear factory LS style plug wires. Designed for maximum ground clearance. If using with Exhaust System 793-91125 some modification will be required (modification of the 793-91125).

* Aftermarket plug wires required for fuel injected applications.
 ** Engine Mounts: Detroit Speed Motor Mount Kit # DSE-060401. Transmission Cross Member: BPT-1002 (Fit up with a 4L60 Transmission).
 **** On convertible Camaro models, the 3.000" system cannot be used. The 2.500" system and use of Hotchkis Performance X-Brace is required. Hotchkis Part# 1404. Subframe: OEM Factory Original GM - Using these headers with any combination other than what is specified may cause fitment issues.

MUSCLE CAR

MUSCLEMAXX®

'68-'74 NOVA

STAINLESS STEEL, CERAMIC COATED & PAINTED HEADERS

► FITS: **LSX** / SBC / BBC

1 YEAR LIMITED WARRANTY

MADE IN THE U.S.A.

- 0.375" thick, laser-cut flanges to provide the ultimate leak-free seal.
- Flanges fit most 23° SBC standard port heads including: D-Port, Fast Burn, LT1, LS and crate engines.
- CNC laser-cut flanges feature raised port location for increased power.
- BBC headers comes painted standard - ceramic coating is optional.
- LSX & SBC headers comes in high-temp, silver ceramic coating inside and out.
- Race-proven stepped tube design for maximum street/strip performance.
- New design clears the following steering boxes: 600 & factory manual/power with 23° aluminum / factory heads / straight or angle plugs.
- Includes bolts and gaskets.
- Direct bolt-on fit.



STAINLESS STEEL



MUSCLE CAR

CERAMIC COATED



BLACK PAINTED



Headers not included with exhaust kit.



Reducer cone kit included w/ all headers.

HEADER TUBE SIZE

| | 2.500" REDUCER | 3.000" REDUCER |
|------------------------------------|----------------|----------------|
| *1.875" (LS SERIES) | 715-11410** | 715-21410 |
| 2.125" - 3.500" (BBC STD) PAINTED | - | 740-59310 |
| 2.125" - 3.500" (BBC TALL) PAINTED | - | 750-91910 |
| *1.875" STAINLESS (LS SERIES) | 715-31425*** | 715-31430*** |

EXHAUST SYSTEM

| | | |
|--------------------|---|--------------|
| Exhaust Kit 3.000" | - | ***793-91130 |
|--------------------|---|--------------|

*** Designed around: Muscle Rods Engine Mount Kit #106-1302-00, Detroit Speed Engine Mount Kit #DSE-060401, Muscle Rods Sure Fit Crossmember Kit #106-2200-00, 4LSOE transmission, factory AC, power brakes, and factory subframe. Steering boxes 600 series/factory manual/power will clear factory LS style plug wires. Designed for maximum ground clearance. If using with Exhaust System 793-91125 some modification will be required (modification of the 793-91125).

* Aftermarket plug wires required for fuel injected applications.
 ** Engine Mounts: Detroit Speed Motor Mount Kit # DSE-060401.
 Transmission Cross Member: BPT-1002 (Fit up with a 4L60 Transmission).
 Subframe: OEM Factory Original GM - Using these headers with any combination other than what is specified may cause fitment issues.

MUSCLE CAR

MUSCLEMAXX®

'68-'72 CHEVELLE

CERAMIC COATED HEADERS

▶ FITS: SBC

1 YEAR LIMITED WARRANTY
MADE IN THE U.S.A.

- 0.375" thick, laser-cut flanges to provide the ultimate leak-free seal.
- Flanges fit most 23° SBC standard port heads including: D-Port, Fast Burn, LT1, and crate engines.
- Comes in high-temp. silver ceramic coating inside and out.
- CNC laser-cut flanges feature a raised port location for increased power.
- Race-proven stepped tube design for maximum street/strip performance.
- Includes bolts and gaskets.
- Direct bolt-on fit.
- 794-03006 Bracket Set is needed for all MuscleMAXX® Camaro & Chevelle headers for factory air compressor mounting.



Reducer cone kit included w/ all headers.



HEADER TUBE SIZE

1.625" - 1.750" (SBC)

2.500" REDUCER

740-13210

3.000" REDUCER

740-23210

STAINLESS STEEL **PRO CRUISER**

BLOCK HUGGER HEADERS

► **FITS: SBC 23°**

1 YEAR LIMITED WARRANTY

For applications where space is a primary concern, sometimes a short header is the only solution. For these cases, we offer our all-stainless Pro Cruiser Series block hugger header. They feature the same exceptional levels of quality, fit, and finish in a compact package.

- SBC Standard 23° 6-bolt pattern.
- 0.375" flange.
- 1.625" primaries.
- 2.500" collector.
- 2.000" reducer cones.
- 100% stainless steel construction.
- Includes bolts & gaskets.



DESCRIPTION

BLOCK HUGGER HOT ROD HEADERS (Fits Straight Head Plugs Only)

PART#

730-10010



Machined flange is flat ground for proper fit and leak-free performance.

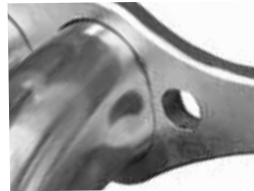

Machined flange features unique bevel that adds a quality look.



High-flow contoured collector for increased power.



Finished welds offer smooth exhaust flow and excellent seal.



ACCESSORIES

FLANGES & GASKETS

MUSCLE CAR APPLICATIONS

A great exhaust system starts at the beginning — the flange. One of Dynatech®'s biggest advantages is our wide selection of port matched flanges. All of our flanges are CNC laser cut for unparalleled quality and fit.



Mild Steel Flanges



Fiber Gasket

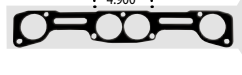
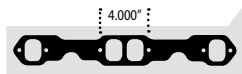

DESCRIPTION

- SMALL BLOCK CHEVY 23°
- SMALL BLOCK CHEVY 23°
- SMALL BLOCK CHEVY 23°
- SMALL BLOCK CHEVY 23°
- SMALL BLOCK CHEVY 18°
- LS1 GM
- STAHL ROUND PATTERN
- SPREAD PORT CHEVY
- SPREAD PORT CHEVY
- SPREAD PORT CHEVY
- BIG BLOCK CHEVY
- BIG BLOCK CHEVY
- BIG BLOCK CHEVY
- BIG BLOCK CHEVY

| FLANGE (single) | PORT | X | Y | THICKNESS | GASKET (pair) |
|--------------------|--------|--------|--------|-----------|------------------|
| 796-00613 | 1.750" | 1.485" | 1.880" | .375" | 794-00001 |
| 796-00622 | 1.625" | 1.485" | 1.685" | .375" | 794-00001 |
| 796-00022 | 1.625" | 1.485" | 1.685" | .250" | 794-00001 |
| 796-00013 | 1.750" | 1.485" | 1.880" | .250" | 794-00001 |
| 796-00564 | 1.875" | 1.839" | 1.697" | .3125" | 794-03001 |
| 796-60514 | 1.875" | 1.946" | 1.946" | .3125" | 794-20001 |
| 796-01514 | 1.875" | 1.944" | 1.944" | .3125" | - |
| 796-00534 | 1.875" | 1.950" | 1.950" | .3125" | 794-00000 |
| 796-00535 | 2.000" | 2.070" | 2.070" | .3125" | 794-00000 |
| 796-00536 | 2.125" | 2.196" | 2.196" | .3125" | 794-00000 |
| 796-31536 | 2.125" | 2.224" | 2.224" | .3125" | 794-50011 |
| 796-21637 | 2.250" | 2.350" | 2.350" | .375" | 794-50001 |
| 796-21638 | 2.375" | 2.476" | 2.476" | .375" | 794-50001 |
| 796-21639 | 2.500" | 2.600" | 2.600" | .375" | 794-50001 |



PREMIUM EXHAUST TIPS

TQ Tips® allow for a flush fit with the outside diameter of your exhaust's tail pipe for a smooth, clean look. Put the finishing touch on your new SuperMAXX® or MuscleMAXX® system.



| DESCRIPTION | PART# |
|-----------------------------------|-----------|
| TQ TIP FOR 2.500" OUTLET (SINGLE) | 794-93025 |
| TQ TIP FOR 3.000" OUTLET (SINGLE) | 794-93030 |
| TQ TIP FOR 2.500" OUTLET (2 PACK) | 794-93026 |
| TQ TIP FOR 3.000" OUTLET (2 PACK) | 794-93031 |

MANDREL BENT J-BENDS

Dynatech® stocks a complete inventory of mandrel bent J-bends. These are made from premium grade mild steel tubing.

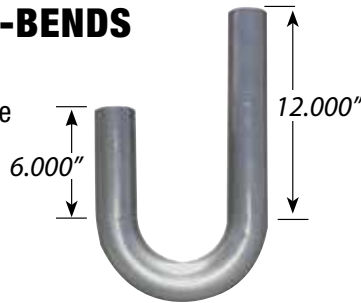

| SIZE | CLR | MILD STEEL PART# | STAINLESS PART# |
|--------|--------|------------------|-----------------|
| 1.625" | 2.625" | 794-60202 | 794-60302 |
| 1.750" | 2.625" | 794-60203 | - |
| 1.875" | 2.813" | 794-60204 | 795-60304 |
| 2.000" | 3.000" | 794-60205 | 794-60305 |
| 2.125" | 3.188" | 794-60206 | - |
| 2.250" | 3.375" | 794-60207 | - |
| 2.325" | 3.563" | 794-60208 | - |
| 2.500" | 3.750" | 794-60209 | 795-60309 |

V-CLAMP KITS



Kit includes two weld-on v-clamp rings and stainless steel v-band clamp. Models for 2.500", 3.000", or 3.500" pipe sizes.

| DESCRIPTION | PART# |
|--------------------------------|-----------|
| V-CLAMP COLLAR ASSEMBLY 2.500" | 794-91225 |
| V-CLAMP COLLAR ASSEMBLY 3.000" | 794-91230 |
| V-CLAMP COLLAR ASSEMBLY 3.500" | 794-91235 |

STEPPED BAND CLAMPS

Smooth transition taper allows proper fit to seal expanded slip-fit connections. Great for muffler, tail pipe and merge pipe connections.



| DESCRIPTION | PART# |
|--------------------------------|-----------|
| BAND CLAMP FOR 2.500" JUNCTION | 789-70250 |
| BAND CLAMP FOR 2.750" JUNCTION | 789-70275 |
| BAND CLAMP FOR 3.000" JUNCTION | 789-70300 |
| BAND CLAMP FOR 3.500" JUNCTION | 789-70350 |

Models for 2.500", 2.750", 3.000" or 3.500" pipe sizes. 1 clamp/pkg.

BALL & SOCKET KIT

Unlike common metal to metal connections, Dynatech®'s unique "4-Bolt, Ball and Socket" connection uses a 0.500" thick, tapered donut gasket, which allows for expansion and contraction while maintaining a long lasting leak free seal. We also use four bolts instead of two or three for added durability. For use with any 3.000" O.D. collector and 100% stainless steel.



| DESCRIPTION | TUBE SIZE | PART# |
|-------------|-----------|-----------|
| STUB KIT | 2.500" | 791-09025 |
| STUB KIT | 3.000" | 791-09030 |

HEADER BOLT KITS

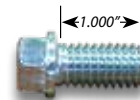

| DESCRIPTION | THREAD | PART# |
|---------------------|--------------|-----------|
| HEX HEAD (16 PACK) | 3/8-16 | 794-00118 |
| HEX BOLTS (12 PACK) | M8 X 1.250mm | 794-50112 |

CERAMIC COATING

All headers purchased with this option are coated inside and outside. The coating will significantly reduce the underhood temperature of your car — which translates into horsepower gain. Headers purchased with this ceramic coating come with a **3 year warranty** and a customer satisfaction guarantee.

| DESCRIPTION | PART# |
|---------------------------------|-----------|
| CERAMIC COATING FOR HEADERS | 790-00100 |
| CERAMIC COATING FOR X & Y PIPES | 790-00101 |
| CERAMIC COATING FOR ELBOWS | 790-00102 |
| CERAMIC COATING FOR COLLECTORS | 790-00103 |



HIGH PERFORMANCE

- Perfect, direct bolt-on fit.
- 0.375" Thick CNC laser-cut flanges.
- 4-Bolt ball & socket collector flanges.
- All flanges machine surfaced after welding.
- 3.000" Wide, 2-bolt band clamps.
- Optimized tube length for H.P. and torque.
- 100% jig assembled and checked for an excellent fit.
- Triple layer stainless steel gaskets.
- T304 stainless steel construction.
- Detailed instructions & all hardware included.

HOW TO PURCHASE YOUR DYNATECH® EXHAUST SYSTEM

1 HEADERS

The headers consist of a long tube set of headers with all of the required hardware included for the installation. The headers alone cannot be installed as a "Bolt In" to your factory catalytic converters and system.



2 INTERMEDIATE SECTION

The intermediate section consists of the required components to connect the headers to your factory or aftermarket "Cat-Back" exhaust system. In most cases, you have two choices when it comes to selecting your intermediate section. You can choose either the "Catted" or "Non Catted" version.

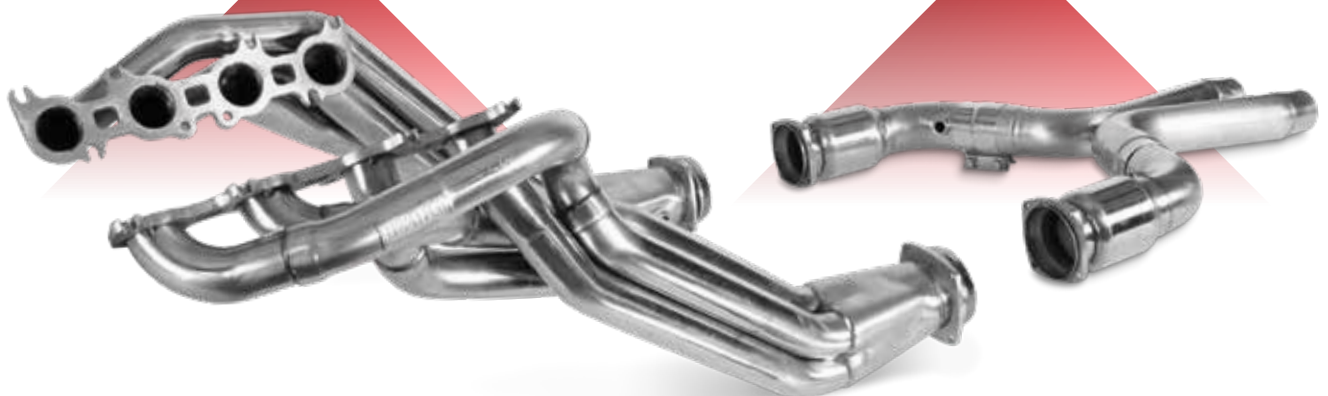

HIGH PERFORMANCE QUICK GUIDE

FORD



| APPLICATION | YEAR | ENGINE | HEADERS | CATTED | NON-CATTED | HP GAIN | INST. TIME | PAGE |
|----------------------|-----------|--------|-----------|-----------|------------|---------|------------|------|
| MUSTANG GT | 2018 | 5.0L | 722-44310 | 722-75320 | 722-75330 | 32 | 5-7 hrs | 33 |
| MUSTANG SHELBY GT350 | '15 - '17 | 5.0L | 722-65310 | 722-65320 | 722-65330 | 26 | 5-6 hrs | 34 |
| MUSTANG GT 5.0 | '11 - '14 | 5.0L | 722-74310 | 722-74320 | 722-74330 | 32 | 5-7 hrs | 35 |
| MUSTANG GT 5.0 | '15 - '17 | 5.0L | 722-74310 | 722-75320 | 722-75330 | 32 | 5-7 hrs | 35 |
| MUSTANG SHELBY GT500 | '07 - '10 | ALL | 722-64310 | 722-54320 | 722-54330 | 15 | 6-8 hrs | 36 |
| MUSTANG SHELBY GT500 | '11 - '14 | ALL | 722-84310 | 722-74420 | 722-74330 | 15 | 6-8 hrs | 36 |
| MUSTANG GT | '05 - '10 | 4.6L | 722-54310 | 722-54320 | 722-54330 | 30 | 5-7 hrs | 37 |

DODGE



| APPLICATION | YEAR | ENGINE | HEADERS | CATTED | NON-CATTED | HP GAIN | INST. TIME | PAGE |
|-----------------------------------|-----------|------------------------|-----------|-----------|------------|---------|------------|------|
| CHALLENGER, MAGNUM, CHARGER, 300C | '05 - '17 | 5.7L HEMI | 724-73310 | 724-73320 | 724-73330 | 30 | 5-7 hrs | 38 |
| CHALLENGER, MAGNUM, CHARGER, 300C | '05 - '17 | SRT-8 6.1L & 6.4L HEMI | 728-73310 | 728-73320 | 728-73330 | 30 | 5-7 hrs | 38 |

GM



| APPLICATION | YEAR | ENGINE | HEADERS | CATTED | NON-CATTED | HP GAIN | INST. TIME | PAGE |
|--------------------------|-----------|--------|-----------|-----------|------------|---------|------------|------|
| CORVETTE C7 | '14 - '18 | V8 | 715-63810 | 715-63820 | 715-63830 | 25 | 6-8 hrs | 39 |
| CORVETTE C7 Z06 | '14 - '18 | V8 | 715-63810 | 715-63920 | 715-63830 | 25 | 6-8 hrs | 39 |
| CORVETTE C6 | '05 - '08 | V8 | 715-63510 | 715-63520 | 715-63530 | 25 | 4-6 hrs | 40 |
| CORVETTE C6 | '09 - '13 | V8 | 715-63510 | 715-63540 | 715-63550 | 25 | 4-6 hrs | 40 |
| CORVETTE C6 Z06 | '05 - '13 | V8 | 715-63510 | 715-63620 | 715-63630 | 25 | 4-6 hrs | 40 |
| CORVETTE C5 | '97 - '00 | V8 | 715-73610 | 715-73720 | 715-73730 | 30 | 4-6 hrs | 41 |
| CORVETTE C5 | '01 - '03 | V8 | 715-73710 | 715-73720 | 715-73730 | 30 | 4-6 hrs | 41 |
| CORVETTE C5 | '04 | V8 | 715-74710 | 715-74720 | 715-74730 | 30 | 4-6 hrs | 41 |
| CADILLAC CTS-V 1.875" | '09 - '15 | 6.2L | 715-75010 | 715-75020 | 715-75030 | 64 | 4-6 hrs | 42 |
| CADILLAC CTS-V 2.000" | '09 - '15 | 6.2L | 715-75210 | 715-75040 | 715-75050 | 64 | 4-6 hrs | 42 |
| CAMARO SS/ZL1 1.875" | '16 - '17 | 6.2L | 715-75510 | 715-75520 | 715-75530 | 28 | 4-6 hrs | 43 |
| CAMARO SS/ZL1 2.000" | '16 - '17 | 6.2L | 715-76010 | 715-75520 | 715-75530 | 28 | 4-6 hrs | 43 |
| CAMARO (5TH GEN.) 1.875" | '10 - '15 | 6.2L | 715-74010 | 715-73920 | 715-73930 | 36 | 4-6 hrs | 44 |
| CAMARO (5TH GEN.) 2.000" | '10 - '15 | 6.2L | 715-74110 | 715-74020 | 715-74030 | 36 | 4-6 hrs | 44 |
| CAMARO, FIREBIRD, F-BODY | '98 - '99 | V8 | 715-73210 | 715-73220 | 715-73230 | 19 | 4-6 hrs | 45 |
| CAMARO, FIREBIRD, F-BODY | '00 - '02 | V8 | 715-73310 | 715-73220 | 715-73230 | 19 | 4-6 hrs | 45 |

FEATURES & BENEFITS

WHAT IS IN A QUALITY SYSTEM?



*0.375" THICK
CNC LASER-CUT
FLANGES*



*DONUT
GASKET*



*TRIPLE LAYER
STAINLESS
STEEL GASKETS*



*3.000" WIDE / 2-BOLT
BAND CLAMPS*

PERFECT, DIRECT BOLT-ON FIT

100% *JIG ASSEMBLED AND CHECKED
FOR AN EXCELLENT FIT*

OPTIMIZED TUBE LENGTH
FOR INCREASED H.P. AND TORQUE

100% T304 *STAINLESS STEEL
CONSTRUCTION*

ALL FLANGES



*MACHINE SURFACED
AFTER WELDING*

MADE IN THE U.S.A.



*DETAILED
INSTRUCTIONS
& HARDWARE
INCLUDED*

NEW!

SUPERMAXX®

2018 MUSTANG GT

STAINLESS STEEL HEADERS

LIMITED LIFETIME WARRANTY

MADE IN THE U.S.A.



5.000" INTERMEDIATE TUBES W/ CATS



5.000" INTERMEDIATE TUBES W/O CATS



FEATURES

PRIMARY TUBE SIZE: 1.875"

COLLECTOR SIZE: 3.000"

SYSTEM TUBE SIZE: 3.000"

MATERIAL: T304 Stainless

TRANS: Manual & Automatic

INCLUDED: Detailed instructions and all needed hardware.

FIT: Some cutting required for any factory or O.E. size aftermarket cat back.

INSTALL TIME: 5-7 hours

+32 HORSEPOWER
+20 FT-LBS TORQUE

Ceramic Coating Services are Available.
Call Dynatect® for Details.

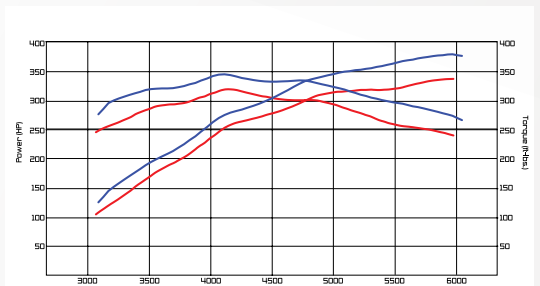

Dyno Chart

■ Stock ■ SuperMAXX®

APPLICATION

2018 MUSTANG GT

HEADERS ONLY

722-44310



INTERMEDIATE TUBES W/ CATS

722-75320



INTERMEDIATE TUBES W/O CATS

722-75330



SUPERMAXX®

'15 - '17 MUSTANG SHELBY GT350

STAINLESS STEEL HEADERS

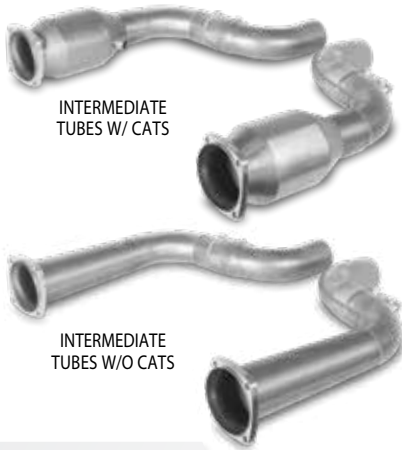

INTERMEDIATE
TUBES W/ CATS

INTERMEDIATE
TUBES W/O CATS



FEATURES

PRIMARY TUBE SIZE: 1.750"-1.875" Stepped
COLLECTOR SIZE: 3.000"
SYSTEM TUBE SIZE: 3.000"
MATERIAL: T304 Stainless
TRANS: Manual & Automatic
INCLUDED: Detailed instructions and all needed hardware.
FIT: Direct Bolt-Up to any factory or O.E. size aftermarket cat back.
INSTALL TIME: 5-6 hours

+26 HORSEPOWER
+13 FT-LBS TORQUE
**with a tune.*

*Ceramic Coating Services
 are Available.
 Call Dynatech® for Details.*

LIMITED LIFETIME WARRANTY
MADE IN THE U.S.A.

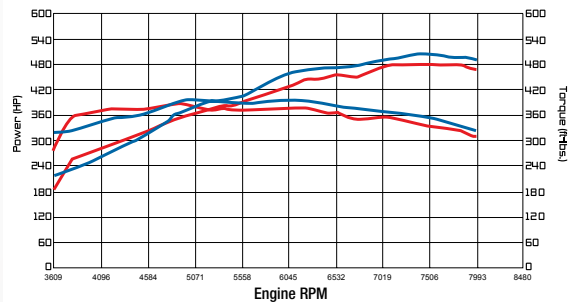

Dyno Chart ■ Stock ■ SuperMAXX®

APPLICATION

'15 - '17 MUSTANG GT350

**HEADERS
ONLY**

722-65310



**INTERMEDIATE
TUBES W/ CATS**

722-65320



**INTERMEDIATE
TUBES W/O CATS**

722-65330



SUPERMAXX®

'11-'17 MUSTANG 5.0

STAINLESS STEEL HEADERS

LIMITED LIFETIME WARRANTY
MADE IN THE U.S.A.



5.000"
INTERMEDIATE
TUBES W/ CATS



5.000"
INTERMEDIATE
TUBES W/O CATS



FEATURES

- PRIMARY TUBE SIZE:** 1.750" - 1.875"
- COLLECTOR SIZE:** 3.000"
- SYSTEM TUBE SIZE:** 3.000"
- MATERIAL:** T304 Stainless
- TRANS:** Manual & Automatic
- INCLUDED:** Detailed instructions and all needed hardware.
- FIT:** Some cutting required for any factory or O.E. size aftermarket cat back.
- INSTALL TIME:** 5-7 hours

+32 HORSEPOWER
+20 FT-LBS TORQUE

*Ceramic Coating Services
 are Available.
 Call Dynatech® for Details.*

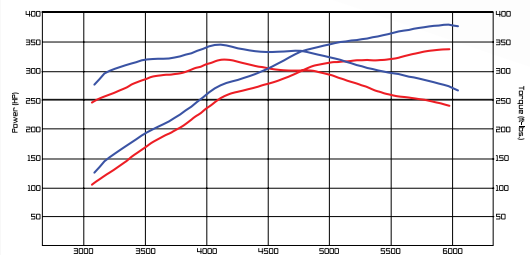

Dyno Chart ■ Stock ■ SuperMAXX®

| APPLICATION | HEADERS ONLY | + | INTERMEDIATE TUBES W/ CATS | OR | INTERMEDIATE TUBES W/O CATS | OR | SUPERCHARGED SUPERCATTED 3.000" |
|-----------------------------------|--------------|---|----------------------------|----|-----------------------------|----|---------------------------------|
| '15 - '17 MUSTANG 5.0/CONVERTIBLE | 722-74310 | | 722-75320 | | 722-75330 | | 722-75420 |
| '11 - '14 MUSTANG 5.0 | 722-74310 | | 722-74320 | | 722-74330 | | 722-74420 |



SUPERMAXX®

'07 - '14 MUSTANG SHELBY GT500

STAINLESS STEEL HEADERS

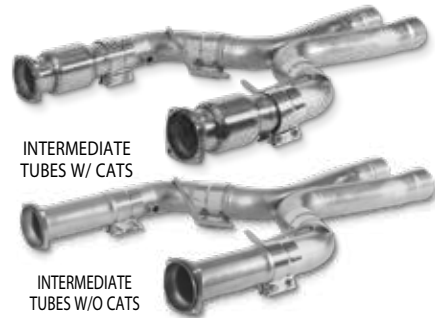

INTERMEDIATE TUBES W/ CATS

INTERMEDIATE TUBES W/O CATS

FEATURES

- PRIMARY TUBE SIZE:** 1.875"
- COLLECTOR SIZE:** 3.000"
- SYSTEM TUBE SIZE:** 2.500" or 3.000"
- MATERIAL:** T304 Stainless
- TRANS:** Manual & Automatic
- INCLUDED:** Detailed instructions and all needed hardware.
- FIT:** Direct Bolt-Up to any factory or O.E. size aftermarket cat back.
- INSTALL TIME:** 6-8 hours

LIMITED LIFETIME WARRANTY
MADE IN THE U.S.A.

Dyno Chart

■ Stock ■ SuperMAXX®

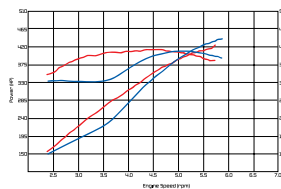

'07-'12
▶ **+15 HORSEPOWER**
▶ **+24 FT-LBS TORQUE**

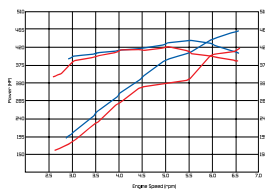

2013
▶ **+49 HORSEPOWER**
▶ **+32 FT-LBS TORQUE**

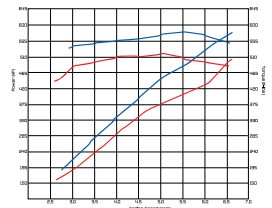

2014
▶ **+70 HORSEPOWER**
▶ **+59 FT-LBS TORQUE**

Ceramic Coating Services are Available.

Call Dynatech® for Details.

DESCRIPTION

HEADERS ONLY

**'07 - '10
SHELBY GT500**

**'11 - '14
SHELBY GT500**

722-64310

722-84310

+ 2.500" INTERMEDIATE TUBES W/ CATS

722-54320

-

2.500" INTERMEDIATE TUBES W/O CATS

722-54330

-

3.000" INTERMEDIATE TUBES W/ CATS (SUPER CATTED)

-

722-74420

3.000" INTERMEDIATE TUBES W/O CATS

-

722-74330



SUPERMAXX®
'05 - '10 MUSTANG GT
STAINLESS STEEL HEADERS

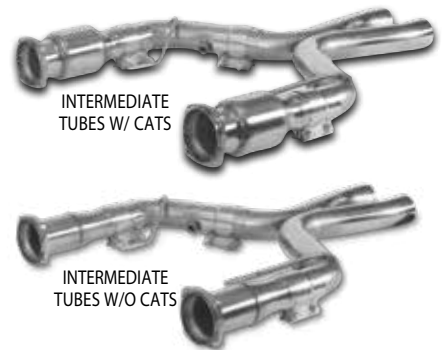

INTERMEDIATE
TUBES W/ CATS

INTERMEDIATE
TUBES W/O CATS

FEATURES

PRIMARY TUBE SIZE: 1.750"
COLLECTOR SIZE: 3.000"
SYSTEM TUBE SIZE: 2.500"
MATERIAL: T304 Stainless
TRANS: Manual & Automatic
INCLUDED: Detailed instructions and all needed hardware.
FIT: Direct Bolt-Up to any factory or O.E. size aftermarket cat back.
INSTALL TIME: 5-7 hours

+30 HORSEPOWER
+30 FT-LBS TORQUE

*Ceramic Coating Services
 are Available.
 Call Dynatech® for Details.*

LIMITED LIFETIME WARRANTY
MADE IN THE U.S.A.

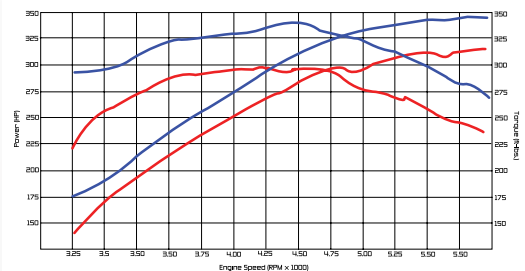

Dyno Chart ■ Stock ■ SuperMAXX®

APPLICATION
 '05 - '10 MUSTANG GT

**HEADERS
 ONLY**
 722-54310



**INTERMEDIATE
 TUBES W/ CATS**
 722-54320



**INTERMEDIATE
 TUBES W/O CATS**
 722-54330



SUPERMAXX®
'05 - '17 CHALLENGER / LIMITED LIFETIME WARRANTY
CHARGER / 300C / MAGNUM **MADE IN THE U.S.A.**

STAINLESS STEEL HEADERS

MATERIAL: T304 Stainless
TRANS: Manual & Automatic
INCLUDED: Detailed instructions and all needed hardware.
FIT: Direct Bolt-Up to any factory or O.E. size aftermarket cat back.
INSTALL TIME: 5-7 hours

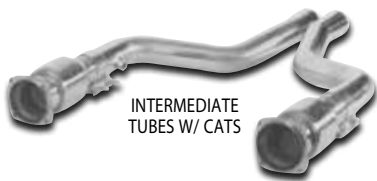

INTERMEDIATE TUBES W/ CATS

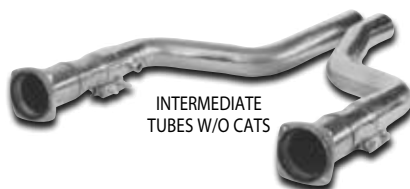

INTERMEDIATE TUBES W/O CATS

5.7 Hemi

PRIMARY TUBE SIZE: 1.750"
COLLECTOR SIZE: 3.000"
SYSTEM TUBE SIZE: 2.500"

+30 HORSEPOWER
+30 FT-LBS TORQUE

SRT-8 (6.1 & 6.4 Hemi)

PRIMARY TUBE SIZE: 1.875"
COLLECTOR SIZE: 3.000"
SYSTEM TUBE SIZE: 2.750" & 3.000"

+30 HORSEPOWER
+24 FT-LBS TORQUE

Ceramic Coating Services are Available.

Call Dynatech® for Details.



SRT-8
Port Matched Flange

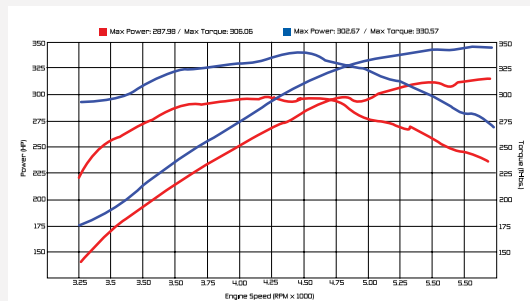

Dyno Chart ■ Stock ■ SuperMAXX®

| DESCRIPTION | 5.7 HEMI |
|-----------------------------|-----------|
| HEADERS ONLY | 724-73310 |
| INTERMEDIATE TUBES W/ CATS | 724-73320 |
| INTERMEDIATE TUBES W/O CATS | 724-73330 |

| DESCRIPTION | SRT-8 |
|------------------------------------|-----------|
| HEADERS ONLY | 728-73310 |
| INTERMEDIATE TUBES W/ CATS | 728-73320 |
| INTERMEDIATE TUBES W/O CATS | 728-73330 |
| 3.000" INTERMEDIATE TUBES W/ CATS | 728-73340 |
| 3.000" INTERMEDIATE TUBES W/O CATS | 728-73350 |



SUPERMAXX®

'14 - '18 CORVETTE C7/Z06

STAINLESS STEEL HEADERS

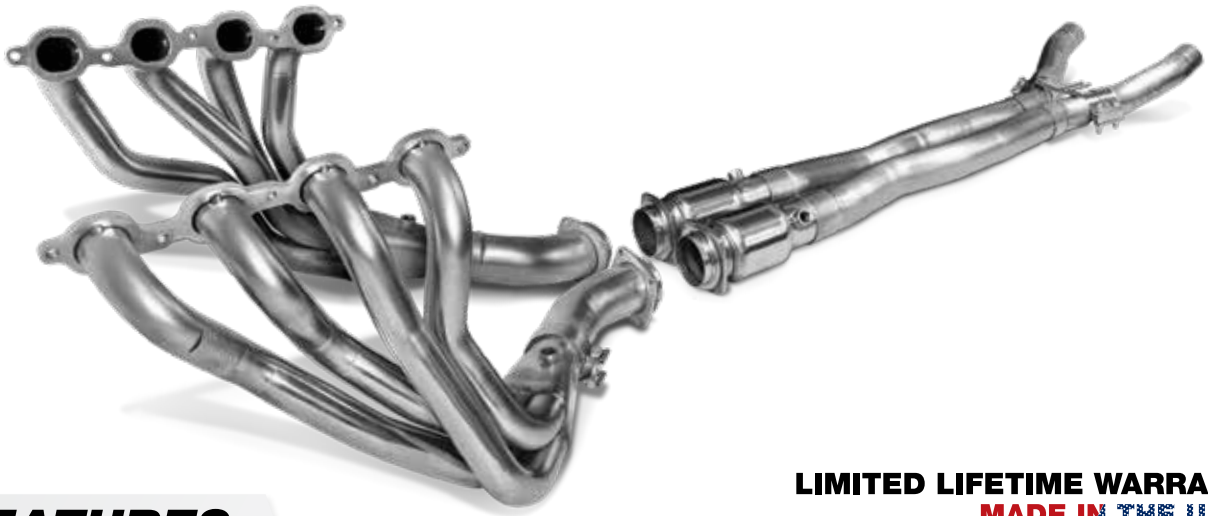

FEATURES

- PRIMARY TUBE SIZE:** 1.875"
- COLLECTOR SIZE:** 3.000"
- SYSTEM TUBE SIZE:** 3.000"
- MATERIAL:** T304 Stainless
- TRANS:** Manual & Automatic
- INCLUDED:** Detailed instructions, and all needed hardware.
- FIT:** Direct Bolt-Up to any factory or O.E. size aftermarket cat back.
- INSTALL TIME:** 6-8 hours

+25 HORSEPOWER
+25 FT-LBS TORQUE

*Ceramic Coating Services
are Available.
Call Dynatech for Details.*

LIMITED LIFETIME WARRANTY
MADE IN THE U.S.A.

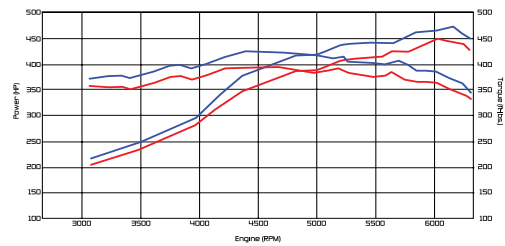

Dyno Chart

■ Stock ■ SuperMAXX®

APPLICATION

'14 - '18 CORVETTE C7
'14 - '18 CORVETTE Z06

HEADERS ONLY

715-63810
715-63810



INTERMEDIATE TUBES W/ CATS

715-63820
715-63920



INTERMEDIATE TUBES W/O CATS

715-63830
715-63830

SUPERMAXX

'05 - '13 CORVETTE C6/Z06

STAINLESS STEEL HEADERS

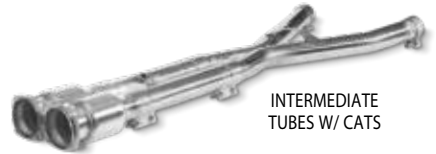

INTERMEDIATE TUBES W/ CATS



INTERMEDIATE TUBES W/O CATS



LIMITED LIFETIME WARRANTY
MADE IN THE U.S.A.

FEATURES

- PRIMARY TUBE SIZE:** 1.875"
- COLLECTOR SIZE:** 3.000"
- SYSTEM TUBE SIZE:** 2.500" or 3.000"
- MATERIAL:** T304 Stainless
- TRANS:** Manual & Automatic
- INCLUDED:** Detailed instructions and all needed hardware.
- FIT:** Direct Bolt-Up to any factory or O.E. size aftermarket cat back.
- INSTALL TIME:** 4-6 hours

+25 HORSEPOWER
+25 FT-LBS TORQUE

Ceramic Coating Services are Available.
Call Dynatech® for Details.

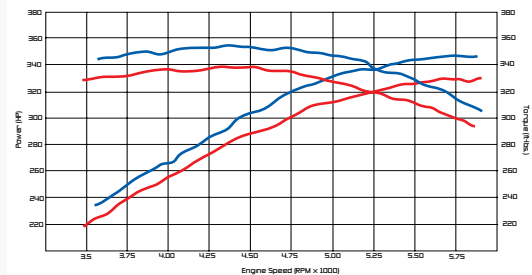

Dyno Chart

■ Stock ■ SuperMAXX®

| APPLICATION | HEADERS ONLY | + | INTERMEDIATE TUBES W/ CATS | OR | INTERMEDIATE TUBES W/O CATS |
|------------------------|--------------|---|----------------------------|----|-----------------------------|
| '05 - '08 CORVETTE C6 | 715-63510 | | 715-63520 | | 715-63530 |
| '09 - '13 CORVETTE C6 | 715-63510 | | 715-63540 | | 715-63550 |
| '05 - '13 CORVETTE Z06 | 715-63510 | | 715-63620 | | 715-63630 |

SUPERMAXX®

'97-'04 CORVETTE C5

STAINLESS STEEL HEADERS



INTERMEDIATE TUBES W/ CATS



INTERMEDIATE TUBES W/O CATS



FEATURES

PRIMARY TUBE SIZE: 1.750"

COLLECTOR SIZE: 3.000"

SYSTEM TUBE SIZE: 2.500"

MATERIAL: T304 Stainless

TRANS: Manual & Automatic

INCLUDED: Detailed instructions and all needed hardware.

FIT: Direct Bolt-Up to any factory or O.E. size aftermarket cat back.

Works with convertible models.

INSTALL TIME: 4-6 hours

**▶ +30 HORSEPOWER
+30 FT-LBS TORQUE**

*Ceramic Coating Services
are Available.*

Call Dynatech® for Details.

LIMITED LIFETIME WARRANTY
MADE IN THE U.S.A.

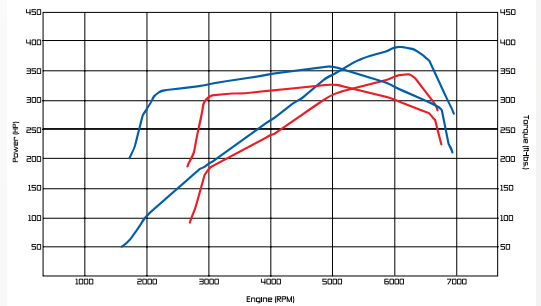

Dyno Chart

■ Stock ■ SuperMAXX®

| APPLICATION | HEADERS ONLY | + | INTERMEDIATE TUBES W/ CATS | OR | INTERMEDIATE TUBES W/O CATS |
|-----------------------|--------------|---|----------------------------|----|-----------------------------|
| '97 - '00 CORVETTE C5 | 715-73610 | | 715-73720 | | 715-73730 |
| '01 - '03 CORVETTE C5 | 715-73710 | | 715-73720 | | 715-73730 |
| '04 CORVETTE C5 | 715-74710 | | 715-74720 | | 715-74730 |

SUPERMAXX

'09 - '15 CADILLAC CTS-V

STAINLESS STEEL HEADERS



FEATURES

- ENGINE:** 6.2L
- PRIMARY TUBE SIZE:** 1.875 or 2.000"
- COLLECTOR SIZE:** 3.000"
- SYSTEM TUBE SIZE:** 2.500" or 3.000"
- MATERIAL:** T304 Stainless
- TRANS:** Manual & Automatic
- INCLUDED:** Detailed instructions and all needed hardware.
- FIT:** Some cutting required for any factory or O.E. size aftermarket cat back.
- INSTALL TIME:** 4-6 hours

+64 HORSEPOWER
+58 FT-LBS TORQUE

Ceramic Coating Services are Available.
Call Dynatech® for Details.

LIMITED LIFETIME WARRANTY
MADE IN THE U.S.A.

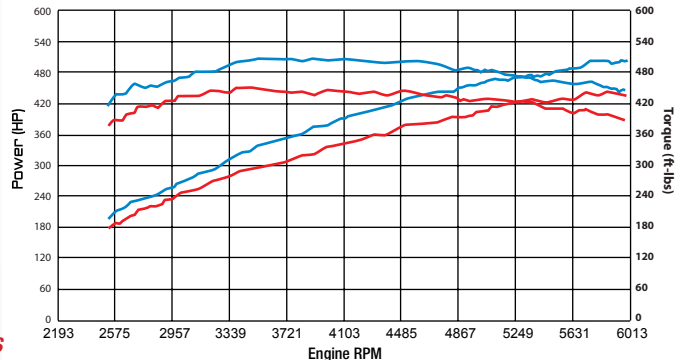

Dyno Chart

■ Stock ■ SuperMAXX®

DESCRIPTION

PART #

| | |
|--|-----------|
| HEADERS ONLY (1.875") | 715-75010 |
| HEADERS ONLY (2.000") | 715-75210 |
| + 2.500" INTERMEDIATE TUBES W/ CATS | 715-75020 |
| 2.500" INTERMEDIATE TUBES W/O CATS | 715-75030 |
| 3.000" INTERMEDIATE TUBES W/ CATS | 715-75040 |
| 3.000" INTERMEDIATE TUBES W/O CATS | 715-75050 |



SUPERMAXX®

'16 - '17 CAMARO SS/ZL1

STAINLESS STEEL HEADERS

INTERMEDIATE
TUBES KIT
(sold separately)



LIMITED LIFETIME WARRANTY
MADE IN THE U.S.A.

FEATURES

- ENGINE:** 6.2L
- PRIMARY TUBE SIZE:** 1.875" or 2.000"
- COLLECTOR SIZE:** 3.000"
- SYSTEM TUBE SIZE:** 2.750"
- MATERIAL:** T304 Stainless
- TRANS:** Manual & Automatic
- INCLUDED:** Detailed instructions and all needed hardware.
- FIT:** Some cutting required for any factory or O.E. size aftermarket cat back.
- INSTALL TIME:** 4-6 Hours

+28 HORSEPOWER
+10 FT-LBS TORQUE

*Ceramic Coating Services
are Available.*
Call Dynatech® for Details.

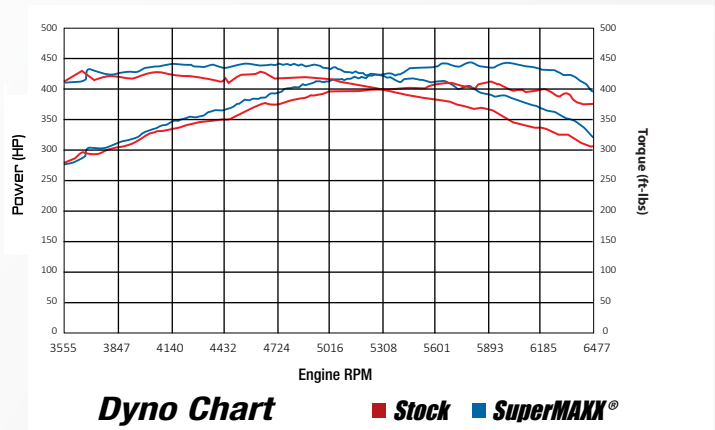

| DESCRIPTION | HEADERS ONLY | + | 2.750" INTERMEDIATE TUBES W/ CATS | OR | 2.750" INTERMEDIATE TUBES W/O CATS | OR | 2.750" INT. TUBES W/ POWERCAT PLUS |
|-------------|--------------|---|-----------------------------------|----|------------------------------------|----|------------------------------------|
| 1.875" | 715-75510 | | 715-75520 | | 715-75530 | | 715-76020 |
| 2.000" | 715-76010 | | 715-75520 | | 715-75530 | | 715-76020 |

'10 - '15 CAMARO (6.2L V8)

STAINLESS STEEL HEADERS

*Fits hard top and convertible models.

**NOW AVAILABLE
FOR Z28**

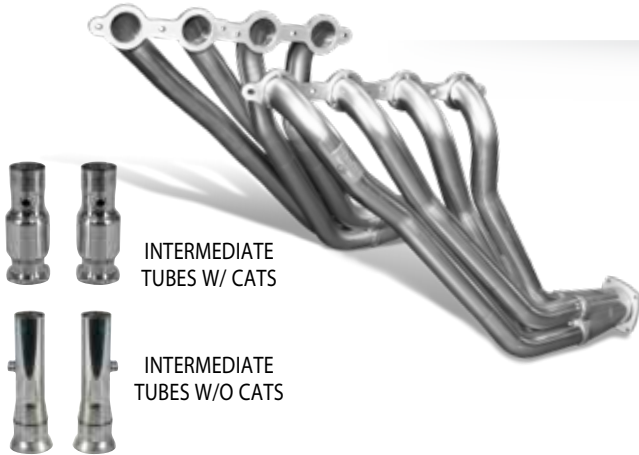

INTERMEDIATE
TUBES W/ CATS

INTERMEDIATE
TUBES W/O CATS



*2010-2015 Chevy Camaro SS
Coupe and Convertible
Stainless Steel Exhaust System (Part #793-73925)
Will not fit Z/28 or ZL1.
Not compatible with factory ground effects.
For models with factory round tail pipes.
May not fit with rectangle rear fascia.

FEATURES

- PRIMARY TUBE SIZE:** 1.875" or 2.000"
- COLLECTOR SIZE:** 3.000"
- SYSTEM TUBE SIZE:** 2.500", 2.750" or 3.000"
- MATERIAL:** T304 Stainless
- TRANS:** Manual & Automatic
- INCLUDED:** Detailed instructions and all needed hardware.
- FIT:** Direct Bolt-Up to any factory or O.E. size aftermarket cat back.
- INSTALL TIME:** 4-6 hours

**+36 HORSEPOWER
+25 FT-LBS TORQUE**

*Ceramic Coating Services
are Available.
Call Dynatech® for Details.*

LIMITED LIFETIME WARRANTY MADE IN THE U.S.A.

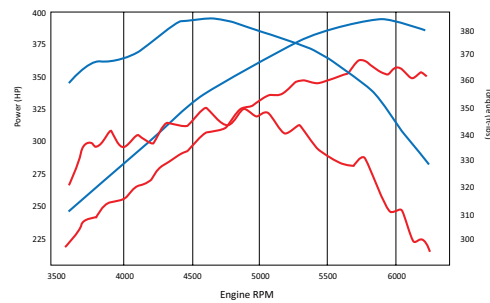

Dyno Chart ■ Stock ■ SuperMAXX®

| DESCRIPTION | Z28 CAMARO | '10 - '15 CAMARO | ZL1 + SUPERCHARGED |
|--|---------------|---------------------|-----------------------|
| HEADERS ONLY (1.875") | 715-74010 | 715-74010 | 715-74010 |
| HEADERS ONLY (2.000") | 715-74110 | 715-74110 | 715-74110 |
| + 2.500" INTERMEDIATE TUBES W/ CATS | . | 715-73920 | . |
| 2.500" INTERMEDIATE TUBES W/O CATS | . | 715-73930 | . |
| 2.750" INTERMEDIATE TUBES W/ CATS | 715-75120 | . | . |
| 2.750" INTERMEDIATE TUBES W/O CATS | 715-74230 | . | . |
| 3.000" INTERMEDIATE TUBES W/ CATS | . | 715-74020 | . |
| 3.000" INTERMEDIATE TUBES W/O CATS | 715-74330 | 715-74030 | . |
| CAT-BACK EXHAUST SYSTEM ('10-'15)* | . | 793-73925 | . |
| 2.500" SUPERCATTED INTER. SECTION | . | . | 715-74120 |
| 3.000" SUPERCATTED INTER. SECTION | . | . | 715-74220 |

SUPERMAXX®

'98 - '02 CAMARO / TRANS AM

STAINLESS STEEL HEADERS

* Will not fit convertible models.

LIMITED LIFETIME WARRANTY
MADE IN THE U.S.A.



FEATURES

- PRIMARY TUBE SIZE:** 1.750"
- COLLECTOR SIZE:** 3.000"
- SYSTEM TUBE SIZE:** 2.500"
- MATERIAL:** T304 Stainless
- TRANS:** Manual & Automatic
- INCLUDED:** Detailed instructions and all needed hardware.
- FIT:** Direct Bolt-Up to any factory or O.E. size aftermarket cat back.
- INSTALL TIME:** 4-6 hours

+19 HORSEPOWER
+15 FT-LBS TORQUE

Ceramic Coating Services are Available.
 Call Dynatech® for Details.

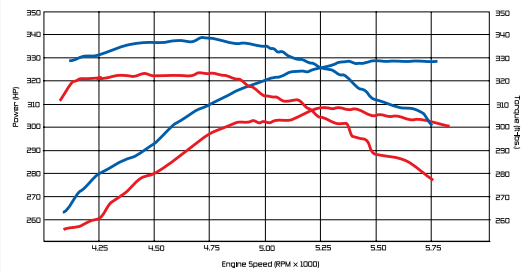

Dyno Chart

■ Stock ■ SuperMAXX®

| APPLICATION | HEADERS ONLY | + | INTERMEDIATE TUBES W/ CATS | OR | INTERMEDIATE TUBES W/O CATS |
|---------------------------------|--------------|---|----------------------------|----|-----------------------------|
| '98 - '99 4TH GENERATION F-BODY | 715-73210 | | 715-73220 | | 715-73230 |
| '00 - '02 4TH GENERATION F-BODY | 715-73310 | | 715-73220 | | 715-73230 |

ACCESSORIES

POWERCAT CATALYTIC CONVERTERS

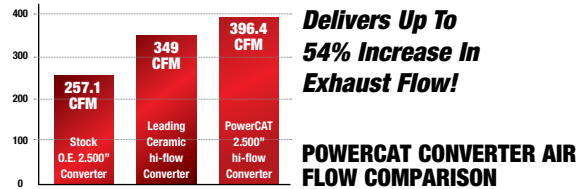

POWERCAT CATALYTIC CONVERTERS

- Premium metallic substrate.
- Superior strength and durability.
- Stainless steel housing.
- Quicker lightoff due to higher thermal conductivity.
- Low pressure drop.
- Higher flow rates compared to stock and most after-market converters.

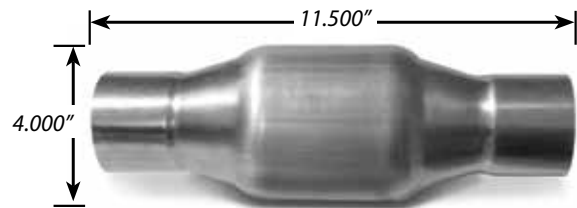

NOTE: These products are intended for racing and off-road applications. Not legal for sale or use in the state of California, nor in states which have adopted California emission standards.

| DESCRIPTION | PART# |
|----------------------------------|-----------|
| POWERCAT 2.250" INLET AND OUTLET | 779-40022 |
| POWERCAT 2.500" INLET AND OUTLET | 779-40025 |
| POWERCAT 3.000" INLET AND OUTLET | 779-40030 |

POWERCAT PLUS CATALYTIC CONVERTERS

- **Designed for supercharged & higher horsepower applications.**
- Premium metallic substrate.
- Superior strength and durability.
- Stainless steel housing.
- Quicker lightoff due to higher thermal conductivity.
- Low pressure drop.
- Higher flow rates compared to stock and most after-market converters.

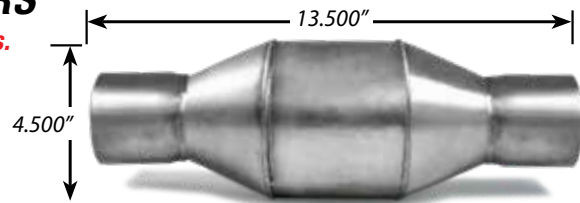

NOTE: These products are intended for racing and off-road applications. Not legal for sale or use in the state of California, nor in states which have adopted California emission standards.

| DESCRIPTION | PART# |
|---|-----------|
| UNIVERSAL POWERCAT PLUS 2.500" INLET / OUTLET | 779-50025 |
| UNIVERSAL POWERCAT PLUS 3.000" INLET / OUTLET | 779-50030 |

ACCESSORIES

BALL & SOCKET KIT



Unlike common metal to metal connections, Dynatech®'s unique "4-Bolt, Ball and Socket" connection uses a 0.500" thick, tapered donut gasket, which allows for expansion and contraction while maintaining a long lasting leak free seal. We also use four bolts instead of two or three for added durability. For use with any 3.000" O.D. collector and 100% stainless steel.

| DESCRIPTION | TUBE SIZE | PART# |
|-------------|-----------|-----------|
| STUB KIT | 2.500" | 791-09025 |
| STUB KIT | 3.000" | 791-09030 |

STEPPED BAND CLAMPS

Smooth transition taper allows proper fit to seal expanded slip-fit connections. Great for muffler, tail pipe, and merge pipe connections.



| DESCRIPTION | PART# |
|--------------------------------|-----------|
| BAND CLAMP FOR 2.500" JUNCTION | 789-70250 |
| BAND CLAMP FOR 2.750" JUNCTION | 789-70275 |
| BAND CLAMP FOR 3.000" JUNCTION | 789-70300 |
| BAND CLAMP FOR 3.500" JUNCTION | 789-70350 |

Models for 2.500", 2.750", 3.000", or 3.500" pipe sizes. 1 clamp/ pkg.

V-CLAMP KITS



Kit includes two weld-on v-clamp rings and stainless steel v-band clamp. Models for 2.500", 3.000", and 3.500" pipe sizes.

| DESCRIPTION | PART# |
|--------------------------------|-----------|
| V-CLAMP COLLAR ASSEMBLY 2.500" | 794-91225 |
| V-CLAMP COLLAR ASSEMBLY 3.000" | 794-91230 |
| V-CLAMP COLLAR ASSEMBLY 3.500" | 794-91235 |

MANDREL BENT J-BENDS

Dynatech® stocks a complete inventory of mandrel bent J-bends. These are made from premium grade mild steel tubing.

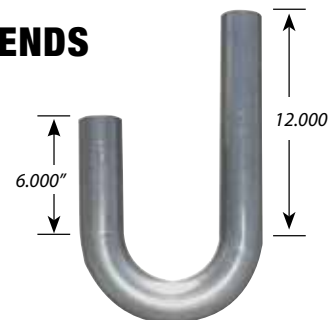

| SIZE | CLR | STAINLESS PART# |
|--------|--------|-----------------|
| 1.625" | 2.625" | 794-60302 |
| 1.875" | 2.813" | 794-60304 |
| 2.000" | 3.000" | 794-60305 |
| 2.500" | 3.750" | 794-60309 |

ACCESSORIES

FLANGES & GASKETS

HIGH PERFORMANCE APPLICATIONS

A great exhaust system starts at the beginning - the flange. One of Dynatech's biggest advantages is our wide selection of port matched flanges. All of our flanges are CNC laser cut for unparalleled quality and fit.













Stainless Steel Flanges



Stainless Steel Gasket



| | DESCRIPTION | FLANGE (single) | PORT | X | Y | THICKNESS | GASKET (pair) |
|---|--------------------------|--------------------|--------|--------|--------|-----------|------------------|
|  | LS1 | 796-13000 | 1.750" | 1.820" | 1.820" | .375" | 794-30001 |
| | LS1 | 796-16061 | 1.875" | 1.940" | 1.940" | .375" | 794-30001 |
| | LS1 | 796-16062 | 2.000" | 2.070" | 2.070" | .375" | 794-30006 |
|  | 4.6 FORD | 796-18061 | 1.750" | 1.824" | 1.824" | .375" | 794-70001 |
|  | 4 VALVE COBRA 4.6L | 796-16071 | 1.875" | 2.243" | 1.465" | .375" | 794-70004 |
|  | 6.1L HEMI | 796-10661 | 1.875" | 2.082" | 1.508" | .375" | 794-20002 |
|  | 5.7L HEMI DRIVERS SIDE | 796-10761 | 1.750" | 1.820" | 1.820" | .375" | 794-10001 |
|  | 5.7L HEMI PASS. SIDE | 796-10762 | 1.750" | 1.820" | 1.820" | .375" | 794-10001 |
|  | 5.4L TRITON FORD 3 VALVE | 796-18062 | 1.625" | 1.696" | 1.696" | .375" | 794-70001 |
|  | 5.4L FORD (PRE 2004) | 796-19061 | 1.625" | 1.696" | 1.696" | .375" | 794-90001 |
|  | 5.0L FORD | 796-17070 | 1.750" | 1.815" | 1.815" | .375" | 794-70005 |
| | 5.0L FORD | 796-17071 | 1.875" | 1.940" | 1.940" | .375" | 794-70005 |
|  | 5.3/6.2L CHEVY LT | 796-13010 | 1.750" | 1.980" | 1.560" | .375" | 794-30007 |
| | 5.3/6.2L CHEVY LT | 796-13011 | 1.875" | 2.100" | 1.680" | .375" | 794-30007 |
| | 5.3/6.2L CHEVY LT | 796-13012 | 2.000" | 2.216" | 1.796" | .375" | 794-30007 |

These products are intended for racing and off-road applications. Not legal for sale or use in the state of California, nor in states which have adopted California emission standards.



TRUCK / SUV

- Perfect, direct bolt-on fit.
- 0.375" Thick CNC laser-cut flanges.
- 3-Bolt ball-&-socket collector flanges.
- All flanges machine surfaced after welding.
- 3.000" Wide, 2-bolt band clamps.

- Optimized tube length for Hp and torque.
- 100% jig assembled and checked for an excellent fit.
- Triple layer stainless steel gaskets.
- T304 stainless steel construction.
- Detailed instructions & all hardware included.

HOW TO PURCHASE YOUR DYNATECH® EXHAUST SYSTEM

1 HEADERS

The headers consist of a long tube set of headers with all of the required hardware included for the installation. The headers alone cannot be installed as a "Bolt In" to your factory catalytic converters and system.



2 INTERMEDIATE SECTION

The intermediate section consists of the required components to connect the headers to your factory or aftermarket "Cat-Back" exhaust system. In most cases, you have two choices when it comes to selecting your intermediate section. You can choose either the "Catted" or "Non Catted" version.

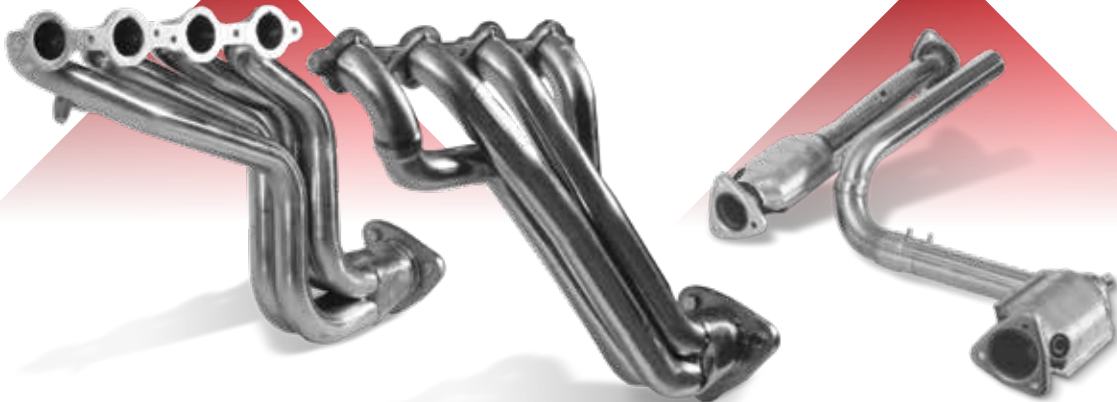

TRUCK / SUV

FORD



| APPLICATION | YEAR | ENGINE | HEADERS | CATTED | NON-CATTED | HP GAIN | INST. TIME | PAGE |
|----------------------------------|-----------|--------|-----------|-----------|------------|---------|------------|------|
| F-150 | '15-'17 | 5.0L | 722-55210 | 722-54220 | 722-54230 | 30 | 5-7 hrs | 52 |
| F-150 | '11-'14 | 5.0L | 722-52210 | 722-52220 | 722-52230 | 31 | 5-7 hrs | 53 |
| F-150 2WD | '04 - '08 | 5.4L | 722-62210 | 722-62320 | - | 14 | 4-6 hrs | 54 |
| F-150 4WD | '04 - '08 | 5.4L | 722-62210 | 722-62220 | 722-62230 | 14 | 4-6 hrs | 54 |
| F-150 LIGHTNING / HARLEY EDITION | '99 - '04 | 5.4L | 722-84210 | 722-84320 | 722-84330 | 20 | 4-6 hrs | 55 |
| F-150 2WD & 4WD | '99 - '03 | 5.4L | 722-84210 | 722-84220 | - | 15 | 4-6 hrs | 55 |

GM



| APPLICATION | YEAR | ENGINE | HEADERS | CATTED | NON-CATTED | HP GAIN | INST. TIME | PAGE |
|--|-----------|-----------------|-----------|-----------|------------|---------|------------|------|
| SILVERADO, AVALANCHE, TAHOE, YUKON, DENALI, ESCALADE | '14 - '18 | 5.3L & 6.2L | 715-34110 | 715-34120 | 715-44120 | 32 | 4-6 hrs | 56 |
| | '07 - '13 | 6.2L | 715-14110 | 715-14620 | - | 15 | 4-6 hrs | 57 |
| | '07 - '13 | 4.8, 5.3 & 6.0L | 715-14110 | 715-14420 | 715-14430 | 15 | 4-6 hrs | 57 |
| | '99 - '06 | 6.0L | 715-84110 | 715-84220 | 715-84230 | 15 | 4-6 hrs | 58 |
| | '99 - '06 | 4.8 - 5.3L | 715-84110 | 715-84120 | 715-84130 | 25 | 4-6 hrs | 58 |
| H2 HUMMER | '07 - '09 | 6.0L | 715-14110 | 715-14320 | 715-14330 | 25 | 4-6 hrs | 59 |
| H2 HUMMER | '00 - '06 | 6.0L | 715-84110 | 715-84220 | 715-84230 | 25 | 4-6 hrs | 59 |

DODGE



| APPLICATION | YEAR | ENGINE | HEADERS | CATTED | NON-CATTED | HP GAIN | INST. TIME | PAGE |
|--------------------|-----------|-----------|-----------|-----------|------------|---------|------------|------|
| DODGE RAM HEMI 2WD | '04 - '05 | 5.7L HEMI | 724-84310 | 724-84520 | - | 17 | 4-6 hrs | 60 |
| DODGE RAM HEMI 4WD | '04 - '05 | 5.7L HEMI | 724-84410 | 724-84620 | - | 17 | 4-6 hrs | 60 |

IT'S ALL IN THE DETAILS



0.375" THICK
CNC LASER-CUT
FLANGES



3 & 4-BOLT BALL &
SOCKET COLLECTOR
FLANGES



TRIPLE LAYER
STAINLESS
STEEL GASKETS



3.000" WIDE / 2-BOLT
BAND CLAMPS

PERFECT, DIRECT BOLT-ON FIT

100% JIG ASSEMBLED AND CHECKED
FOR AN EXCELLENT FIT

OPTIMIZED TUBE LENGTH
FOR INCREASED H.P. AND TORQUE

100% T304 STAINLESS STEEL
CONSTRUCTION

ALL FLANGES



MACHINE SURFACED
AFTER WELDING

MADE IN THE U.S.A.



DETAILED
INSTRUCTIONS
& HARDWARE
INCLUDED



SUPERMAXX®

'15 - '17 FORD F-150

STAINLESS STEEL HEADERS



FEATURES

- PRIMARY TUBE SIZE:** 1.875"
- COLLECTOR SIZE:** 2.500"
- SYSTEM TUBE SIZE:** 2.500"
- MATERIAL:** T304 Stainless Steel
- TRANS:** Manual & Automatic
- INCLUDED:** Detailed instructions and all needed hardware.
- FIT:** Some cutting required for any factory or O.E. size aftermarket cat back.
- INSTALL TIME:** 5-7 hours

+30 HORSEPOWER
+47 FT-LBS TORQUE

Ceramic Coating Services are Available.
Call Dynatech® for Details.

LIMITED LIFETIME WARRANTY
MADE IN THE U.S.A.

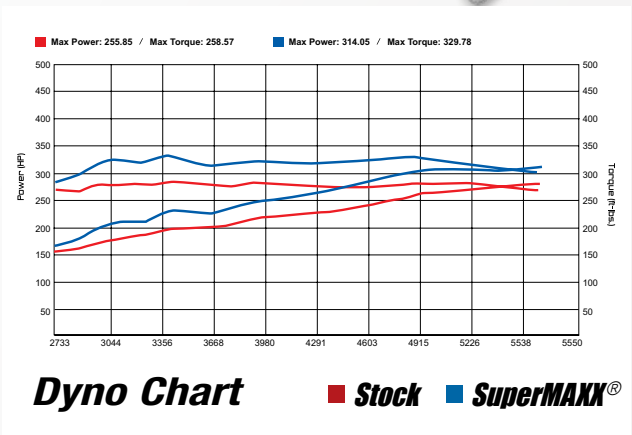

DESCRIPTION

1.875" HEADERS

INTERMEDIATE SECTION W/CATS

INTERMEDIATE SECTION W/O CATS

PART

722-55210

722-54220

722-54230



SUPERMAXX

'11 - '14 FORD F-150

STAINLESS STEEL HEADERS



INTERMEDIATE
TUBES W/ CATS



INTERMEDIATE
TUBES W/O CATS

FEATURES

PRIMARY TUBE SIZE: 1.750" & 1.875"

COLLECTOR SIZE: 2.500"

SYSTEM TUBE SIZE: 2.500"

MATERIAL: T304 Stainless

TRANS: Manual & Automatic

INCLUDED: Detailed instructions and all needed hardware.

FIT: Some cutting required for any factory or O.E. size aftermarket cat back.

INSTALL TIME: 5-7 hours

+31 HORSEPOWER
+27 FT-LBS TORQUE

LIMITED LIFETIME WARRANTY
MADE IN THE U.S.A.

Ceramic Coating Services are Available.

Call Dynatech® for Details.

DESCRIPTION

1.750" HEADER SET

1.875" HEADER SET

CATTED SECTION

NON-CATTED SECTION

PART

722-52210

722-53210

722-52220

722-52230



SUPERMAXX

'04 - '08 FORD F-150

STAINLESS STEEL HEADERS



INTERMEDIATE
TUBES W/ CATS



INTERMEDIATE
TUBES W/O CATS



FEATURES

PRIMARY TUBE SIZE: 1.625"

COLLECTOR SIZE: 2.500"

SYSTEM TUBE SIZE: 2.500"

MATERIAL: T304 Stainless

TRANS: Manual & Automatic

INCLUDED: Detailed instructions and all needed hardware.

FIT: Direct Bolt-Up to any factory or O.E. size aftermarket cat back.

INSTALL TIME: 4-6 hours

+14 HORSEPOWER
+9 FT-LBS TORQUE

LIMITED LIFETIME WARRANTY
MADE IN THE U.S.A.

Ceramic Coating Services are Available.
Call Dynatech® for Details.

| DESCRIPTION | '04 - '08 2WD (5.4L) | '04 - '08 4WD (5.4L) |
|-----------------------------|-------------------------|-------------------------|
| HEADERS ONLY | 722-62210 | 722-62210 |
| INTERMEDIATE TUBES W/ CATS | 722-62320 | 722-62220 |
| INTERMEDIATE TUBES W/O CATS | . | 722-62230 |

SUPERMAXX[®]

'99 - '03 FORD F-150

'99 - '04 FORD LIGHTNING/HARLEY

STAINLESS STEEL HEADERS



CAT BACK EXHAUST SYSTEM FOR LIGHTNING ONLY



FEATURES

PRIMARY TUBE SIZE: 1.625"

COLLECTOR SIZE: 2.500"

SYSTEM TUBE SIZE: 2.500"

MATERIAL: T304 Stainless

TRANS: Manual & Automatic

INCLUDED: Detailed instructions and all needed hardware.

FIT: Direct Bolt-Up to any factory or O.E. size aftermarket cat back.

INSTALL TIME: 4-6 hours

+20 HORSEPOWER
+14 FT-LBS TORQUE

LIMITED LIFETIME WARRANTY
MADE IN THE U.S.A.

Ceramic Coating Services are Available.
Call Dynatech[®] for Details.



INTERMEDIATE TUBES W/ CATS FOR F-150



INTERMEDIATE TUBES W/ CATS FOR LIGHTNING



INTERMEDIATE TUBES W/O CATS FOR LIGHTNING

| DESCRIPTION | '99 - '03 F-150 2WD/4WD (5.4L) | '99 - '04 LIGHTNING '02 - '03 HARLEY |
|---|--------------------------------|--------------------------------------|
| HEADERS ONLY | 722-84210 | 722-84210 |
| INTERMEDIATE TUBES W/ CATS | 722-84220 | 722-84320 |
| INTERMEDIATE TUBES W/O CATS | . | 722-84330 |
| CAT BACK SYSTEM: X-PIPE W/ DUAL 4.000" MUFFLERS | . | 722-84231 |

SUPERMAXX®

'14 - '18 CHEVY/GMC 1500 TRUCK & SUV STAINLESS STEEL HEADERS

NEW!

LIMITED LIFETIME WARRANTY
MADE IN THE U.S.A.



+32 HORSEPOWER
+43 FT-LBS TORQUE

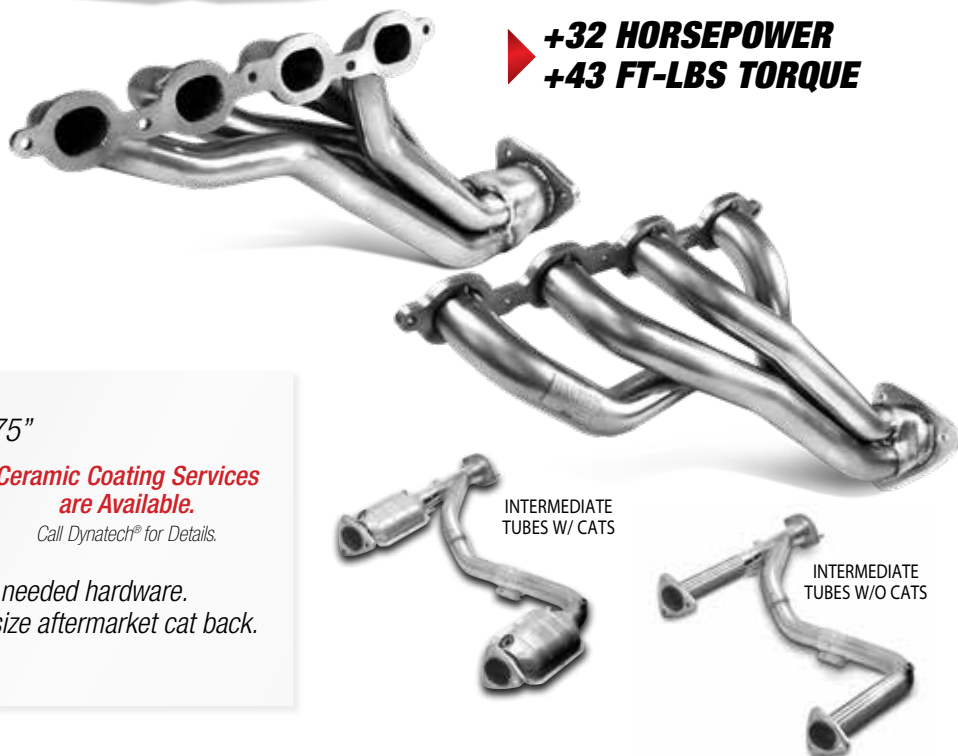

FEATURES

PRIMARY TUBE SIZE: 1.750" or 1.875"

COLLECTOR SIZE: 2.500"

SYSTEM TUBE SIZE: 2.500"

MATERIAL: T304 Stainless

TRANS: Manual or Automatic

INCLUDED: Detailed instructions and all needed hardware.

FIT: Direct Bolt-up to any factory or O.E. size aftermarket cat back.

INSTALL TIME: 4-6 hours

*Ceramic Coating Services
are Available.*

Call Dynatech® for Details.

| HEADER PRIMARY TUBE SIZE | PART # | ENGINE |
|--------------------------|-----------|-------------|
| 1.750" | 715-34110 | 5.3L & 6.2L |
| 1.875" | 715-44110 | 5.3L & 6.2L |

| DESCRIPTION | PART # | ENGINE | CATS |
|---------------------------|-----------|--------|----------|
| INTERMEDIATE TUBE SECTION | 715-34120 | 5.3L | W/CATS |
| INTERMEDIATE TUBE SECTION | 715-34130 | 5.3L | W/O CATS |
| INTERMEDIATE TUBE SECTION | 715-44120 | 6.2L | W/ CATS |
| INTERMEDIATE TUBE SECTION | 715-44130 | 6.2L | W/O CATS |



SUPERMAXX[®]

'07 - '13 CHEVY 1500 TRUCK / SUV

STAINLESS STEEL HEADERS



INTERMEDIATE
TUBES W/ CATS



INTERMEDIATE
TUBES W/O CATS

FEATURES

PRIMARY TUBE SIZE: 1.750"

COLLECTOR SIZE: 2.500"

SYSTEM TUBE SIZE: 2.500"

MATERIAL: T304 Stainless

TRANS: Manual & Automatic

INCLUDED: Detailed instructions and all needed hardware.

FIT: Direct Bolt-Up to any factory or O.E. size aftermarket cat back.

INSTALL TIME: 4-6 hours

*Ceramic Coating
Services are
Available.*

Call Dynatech[®] for Details.

**▶ +15 HORSEPOWER
+38.5 FT-LBS TORQUE**

| '07 - '13 (4.8L, 5.3L, & 6.0L) / DESCRIPTION | PART# |
|--|-----------|
| HEADERS ONLY | 715-14110 |
| INTERMEDIATE TUBES W/ CATS ('07-'08) | 715-14120 |
| INTERMEDIATE TUBES W/O CATS ('07-'08) | 715-14130 |
| INTERMEDIATE TUBES W/ CATS ('09-'13) | 715-14420 |
| INTERMEDIATE TUBES W/O CATS ('09-'13) | 715-14430 |

| '07 - '13 (6.2L) / DESCRIPTION | PART# |
|---------------------------------------|-----------|
| HEADERS ONLY | 715-14110 |
| INTERMEDIATE TUBES W/ CATS ('07-'10) | 715-14220 |
| INTERMEDIATE TUBES W/O CATS ('07-'10) | 715-14230 |
| INTERMEDIATE TUBES W/ CATS ('11-'13) | 715-14620 |

LIMITED LIFETIME WARRANTY
MADE IN THE U.S.A.



SUPERMAXX

'99-'06 CHEVY 1500 TRUCK / SUV

STAINLESS STEEL HEADERS



FEATURES

PRIMARY TUBE SIZE: 1.750"
COLLECTOR SIZE: 2.500"
SYSTEM TUBE SIZE: 2.500"
MATERIAL: T304 Stainless
TRANS: Manual & Automatic
INCLUDED: Detailed instructions and all needed hardware.
FIT: Direct Bolt-Up to any factory or O.E. size aftermarket cat back.
INSTALL TIME: 4-6 hours

+25 HORSEPOWER
+15 FT-LBS TORQUE

Ceramic Coating Services are Available.

Call Dynatech® for Details.

LIMITED LIFETIME WARRANTY
MADE IN THE U.S.A.



| DESCRIPTION | '99 - '06 CHEVY TRUCK (4.8L & 5.3L) | '99 - '06 CHEVY TRUCK (6.0L) |
|-----------------------------|-------------------------------------|------------------------------|
| HEADERS ONLY | 715-84110 | 715-84110 |
| INTERMEDIATE TUBES W/ CATS | 715-84120 | 715-84220 |
| INTERMEDIATE TUBES W/O CATS | 715-84130 | 715-84230 |



SUPERMAXX

'00 - '09 HUMMER H2

STAINLESS STEEL HEADERS

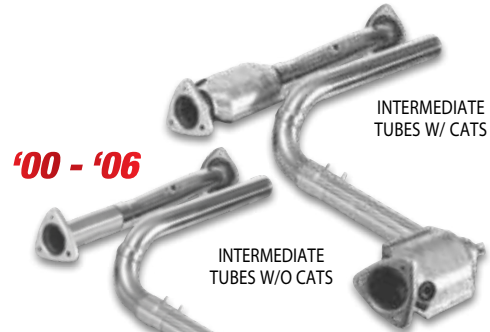

FEATURES

PRIMARY TUBE SIZE: 1.750"
COLLECTOR SIZE: 2.500"
SYSTEM TUBE SIZE: 2.500"
MATERIAL: T304 Stainless
TRANS: Manual & Automatic
INCLUDED: Detailed instructions and all needed hardware.
FIT: Direct Bolt-Up to any factory or O.E. size aftermarket cat back.
INSTALL TIME: 4-6 hours

▶ **+25 HORSEPOWER**
+15 FT-LBS TORQUE

Ceramic Coating Services are Available.
 Call Dynatech® for Details.

LIMITED LIFETIME WARRANTY
MADE IN THE U.S.A.

| DESCRIPTION | '00 - '06 HUMMER H2 | '07 - '09 HUMMER H2 |
|-----------------------------|---------------------|---------------------|
| HEADERS ONLY | 715-84110 | - |
| HEADERS ONLY | - | 715-14110 |
| INTERMEDIATE TUBES W/ CATS | 715-84220 | 715-14320 |
| INTERMEDIATE TUBES W/O CATS | 715-84230 | 715-14330 |



SUPERMAXX

'04 - '05 DODGE 1500 2WD/4WD

STAINLESS STEEL HEADERS

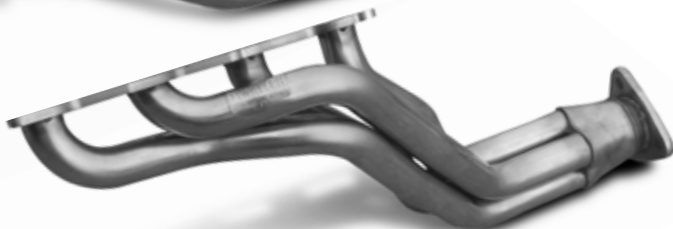

FIT 5.7L HEMI
ENGINE ONLY

FEATURES

PRIMARY TUBE SIZE: 1.750"

COLLECTOR SIZE: 2.500"

SYSTEM TUBE SIZE: 2.500"

MATERIAL: T304 Stainless

TRANS: Manual & Automatic

INCLUDED: Detailed instructions and all needed hardware.

FIT: Direct Bolt-Up to any factory or O.E. size aftermarket cat back.

INSTALL TIME: 4-6 hours

+17 HORSEPOWER
+15 FT-LBS TORQUE

LIMITED LIFETIME WARRANTY
MADE IN THE U.S.A.

Ceramic Coating Services are Available.

Call Dynatech® for Details.

| DESCRIPTION | HEADERS (5.7L HEMI) |
|--------------------------------|------------------------|
| 2WD HEADERS ONLY | 724-84310 |
| 4WD HEADERS ONLY | 724-84410 |
| 2WD INTERMEDIATE TUBES W/ CATS | 724-84520 |
| 4WD INTERMEDIATE TUBES W/ CATS | 724-84620 |

POWERCAT CATALYTIC CONVERTERS

- Premium metallic substrate.
- Superior strength and durability.
- Stainless steel housing.
- Quicker lightoff due to higher thermal conductivity.
- Low pressure drop.
- Higher flow rates compared to stock and most after-market converters.

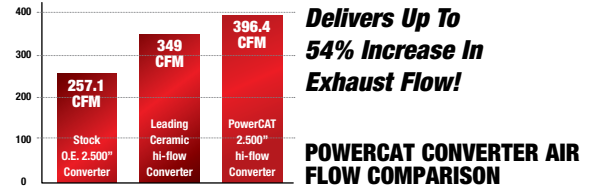

POWERCAT CATALYTIC CONVERTERS



| TUBE SIZE | PART# |
|----------------------------------|-----------|
| POWERCAT 2.250" INLET AND OUTLET | 779-40022 |
| POWERCAT 2.500" INLET AND OUTLET | 779-40025 |
| POWERCAT 3.000" INLET AND OUTLET | 779-40030 |

NOTE: These products are intended for racing and off-road applications. Not legal for sale or use in the state of California, nor in states which have adopted California emission standards.

POWERCAT PLUS CATALYTIC CONVERTERS

Designed for supercharged & higher horsepower applications.

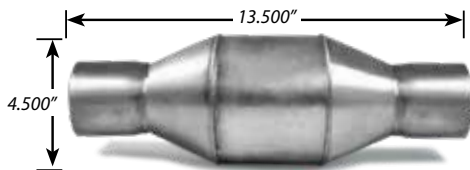

| TUBE SIZE | PART# |
|-------------------------------------|-----------|
| POWERCAT PLUS 2.500" INLET / OUTLET | 779-50025 |
| POWERCAT PLUS 3.000" INLET / OUTLET | 779-50030 |

NOTE: These products are intended for racing and off-road applications. Not legal for sale or use in the state of California, nor in states which have adopted California emission standards.

STEPPED BAND CLAMPS

Smooth transition taper allows proper fit to seal expanded slip-fit connections. Great for muffler, tail pipe and merge pipe connections.



| DESCRIPTION | PART# |
|--------------------------------|-----------|
| BAND CLAMP FOR 2.500" JUNCTION | 789-70250 |
| BAND CLAMP FOR 2.750" JUNCTION | 789-70275 |
| BAND CLAMP FOR 3.000" JUNCTION | 789-70300 |
| BAND CLAMP FOR 3.500" JUNCTION | 789-70350 |

Models for 2.500", 2.750", 3.000" or 3.500" pipe sizes. 1 clamp/ pkg.

STAINLESS STEEL MANDREL BENT J-BENDS

Dynatech® stocks a complete inventory of mandrel bent J-bends. These are made from premium grade mild steel tubing.

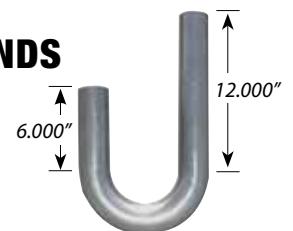

| SIZE | CLR | STAINLESS PART# |
|--------|--------|-----------------|
| 1.625" | 2.625" | 794-60302 |
| 1.875" | 2.813" | 794-60304 |
| 2.000" | 3.000" | 794-60305 |
| 2.500" | 3.750" | 794-60309 |

ACCESSORIES

FLANGES & GASKETS

HIGH PERFORMANCE APPLICATIONS

A great exhaust system starts at the beginning - the flange. One of Dynatech®'s biggest advantages is our wide selection of port matched flanges. All of our flanges are CNC laser cut for unparalleled quality and fit.













Stainless Steel Flanges



Stainless Steel Gasket



| | DESCRIPTION | FLANGE (single) | PORT | X | Y | THICKNESS | GASKET (pair) |
|---|--------------------------|--------------------|--------|--------|--------|-----------|------------------|
|  | LS1 | 796-13000 | 1.750" | 1.820" | 1.820" | .375" | 794-30001 |
| | LS1 | 796-16061 | 1.875" | 1.940" | 1.940" | .375" | 794-30001 |
| | LS1 | 796-16062 | 2.000" | 2.070" | 2.070" | .375" | 794-30006 |
|  | 4.6 FORD | 796-18061 | 1.750" | 1.824" | 1.824" | .375" | 794-70001 |
|  | 4 VALVE COBRA 4.6L | 796-16071 | 1.875" | 2.243" | 1.465" | .375" | 794-70004 |
|  | 6.1L HEMI | 796-10661 | 1.875" | 2.082" | 1.508" | .375" | 794-20002 |
|  | 5.7L HEMI DRIVERS SIDE | 796-10761 | 1.750" | 1.820" | 1.820" | .375" | 794-10001 |
|  | 5.7L HEMI PASS. SIDE | 796-10762 | 1.750" | 1.820" | 1.820" | .375" | 794-10001 |
|  | 5.4L TRITON FORD 3 VALVE | 796-18062 | 1.625" | 1.696" | 1.696" | .375" | 794-70001 |
|  | 5.4L FORD (PRE 2004) | 796-19061 | 1.625" | 1.696" | 1.696" | .375" | 794-90001 |
|  | 5.0L FORD | 796-17070 | 1.750" | 1.815" | 1.815" | .375" | 794-70005 |
| | 5.0L FORD | 796-17071 | 1.875" | 1.940" | 1.940" | .375" | 794-70005 |
|  | 5.3/6.2L CHEVY LT | 796-13010 | 1.750" | 1.980" | 1.560" | .375" | 794-30007 |
| | 5.3/6.2L CHEVY LT | 796-13011 | 1.875" | 2.100" | 1.680" | .375" | 794-30007 |
| | 5.3/6.2L CHEVY LT | 796-13012 | 2.000" | 2.216" | 1.796" | .375" | 794-30007 |



OVAL TRACK



602 CRATE ENGINES:

602 Crate Engines have a unique cylinder head port design. A common misconception is that a special flange is required on the header in order for the header to work. With some brands of headers, this is a true statement. However with Dynatech® headers, a special flange is not required because with our unique design, the flange works with both standard Chevy and 602 Crate Engine heads. As a result, our customers will see added savings by not having to buy another set of headers when switching to or from a 602 Crate Engine. Be sure to look for the 602 Crate logo beside our header listings.



604 CRATE ENGINES:

604 Crate Engines have a unique cylinder head port design that, unlike the 602 Crate engines, has a much higher port ceiling. This requires a special flange to obtain maximum exhaust flow. Dynatech® has responded to these demands by offering a flange specifically designed for the 604 Crate Engines. This flange is currently offered on a number of our headers. If you find an application in our catalog that does not offer this unique flange on the header, please contact us and request it. We are always looking for more ways to satisfy our customers.



FEATURES & BENEFITS

OVAL TRACK EXHAUST



1/2 SET CRASH REPLACEMENTS AVAILABLE

100% JIG ASSEMBLED AND CHECKED FOR AN EXCELLENT FIT

OPTIMIZED TUBE LENGTH FOR MAXIMUM H.P. AND TORQUE

17 GAUGE STAINLESS & MILD STEEL CONSTRUCTION

ALWAYS CHECK YOUR SANCTIONING BODY'S RULE BOOK FOR COMPLIANCE BEFORE MAKING A PURCHASE.

CNC LASER CUT FLANGES



ALL FLANGES MACHINE SURFACED AFTER WELDING

MADE IN THE U.S.A.

High Temperature Ceramic Coating

Inside & Outside • Available Upon Request

WHY SETTLE FOR LESS?

All Dynatech® header flanges are machine surfaced after final welding to prevent leakage.



Dynatech



OTHERS



ALIEN • HARRIS • TAYLOR • BMS • SKYROCKET • GRT • DIRT BOSS

MADE IN THE U.S.A.

- Accommodates raising the engine 1.500".
- High quality stainless steel for increased header life and exhaust velocity vs. mild steel.
- Fully TIG-welded construction improves weld quality.
- 9.000" long collector for IMCA rules.
- Laser cut flanges w/ 604 crate port design.
- 3.000" inch collector outlet diameter.
- Triple-step long tube design optimized on "in-house" engine dyno.
- Gaskets and bolts included.
- Accommodates raised & offset engine positions.
- 1/2 sets are available for crash replacement.
- Ceramic coating services are available.
Call Dynatech® for details.
- 1 Year Limited Warranty.



| DESCRIPTION | TUBE SIZE | COLL. | H.P. | PART # |
|------------------------------------|----------------------|--------|-----------|------------------|
| 604 CRATE - STAINLESS STEEL | 1.625"-1.750"-1.875" | 3.000" | 604 CRATE | 701-17210 |



2010-2014 SHAW CHASSIS

MADE IN THE U.S.A.

- Accommodates raising the engine 1.000".
- High quality stainless steel for increased header life and exhaust velocity vs. mild steel.
- Fully TIG-welded construction improves weld quality.
- 9.000" long collector for IMCA rules.
- Laser cut flanges w/ 604 crate port design.
- Three inch collector outlet diameter.
- Triple-step long tube design optimized on "in-house" engine dyno.
- Gaskets and bolts included.
- Accommodates raised & offset engine positions.
- 1/2 sets are available for crash replacement.
- Ceramic coating services are available.
Call Dynatech® for details.
- 1 Year Limited Warranty.



| DESCRIPTION | TUBE SIZE | COLL. | H.P. | PART # |
|------------------------------------|----------------------|--------|-----------|------------------|
| 604 CRATE - STAINLESS STEEL | 1.625"-1.750"-1.875" | 3.000" | 604 CRATE | 701-17310 |

CRATE MODIFIED



2010-2015 JET CHASSIS
2015 KAZZBUILT CHASSIS

MADE IN THE U.S.A.

- Accommodates raising the engine 1.250".
- High quality stainless steel for increased header life and exhaust velocity vs. mild steel.
- Fully TIG-welded construction improves weld quality.
- 9.000" long collector for IMCA rules.
- Laser cut flanges w/ 604 crate port design.
- Three inch collector outlet diameter.
- Triple-step long tube design optimized on "in-house" engine dyno.
- Gaskets and bolts included.
- Accommodates raised & offset engine positions.
- 1/2 sets are available for crash replacement.
- Ceramic coating services are available.
Call Dynatech® for details.
- 1 Year Limited Warranty.



| DESCRIPTION | TUBE SIZE | COLL. | H.P. | PART # |
|-----------------------------|----------------------|--------|-----------|-----------|
| 604 CRATE - STAINLESS STEEL | 1.625"-1.750"-1.875" | 3.000" | 604 CRATE | 701-17410 |



**HARRIS • SKYROCKET • HUGHES
• VICTORY • BMS • JET**

- Fits standard Chevy engines with angle or straight plug heads.
- Gaskets and bolts included.
- 1/2 sets available.
- Ceramic coating services are available. Call Dynatech® for details.
- 1 Year Limited Warranty.



MADE IN THE U.S.A.

| DESCRIPTION | TUBE SIZE | COLL. | H.P. | INTERCHANGE # | PART # |
|----------------|-----------|--------|---------|---------------|-----------|
| STANDARD CHEVY | 1.750" | 3.500" | 350-450 | 11629H | 701-16510 |

**DIRT WORKS • IMPRESSIVE • LIGHTNING
• HOFFMAN • SHAW**

- Fits standard Chevy engines with angle or straight plug heads.
- Gaskets and bolts included.
- 1/2 sets available.
- Slip on collectors.
- Ceramic coating services are available. Call Dynatech® for details.
- 1 Year Limited Warranty.



MADE IN THE U.S.A.

| DESCRIPTION | TUBE SIZE | COLL. | H.P. | INTERCHANGE # | PART # |
|----------------|-----------|--------|---------|---------------|-----------|
| STANDARD CHEVY | 1.750" | 3.500" | 300-450 | 172 & 172CM | 701-19810 |

**DIRT WORKS • BMS • JET • SMILEY'S
• PIERCE • HOFFMAN • VICTORY • LAZER**

- Fits angle or straight plug heads.
- Gaskets and bolts included.
- Longer primaries for maximum torque and horsepower.
- 1/2 sets available.
- Ceramic coating services are available. Call Dynatech® for details.
- 1 Year Limited Warranty.



MADE IN THE U.S.A.

| DESCRIPTION | TUBE SIZE | COLL. | H.P. | INTERCHANGE # | PART # |
|----------------|-----------------|--------|------|---------------|-----------|
| STANDARD CHEVY | 1.750" - 1.875" | 3.500" | 450+ | 1186V | 701-10610 |

MODIFIED

2010-2014 SHAW CHASSIS

MADE IN THE U.S.A.

- Accommodates raising the engine 1.000".
- 9.000" long collector for IMCA rules.
- 3.000" inch collector outlet diameter.
- 1-5/8" Straight through design for crate motors and classes that require 1-5/8" tubes.
- Gaskets and bolts included.
- Accommodates raised & offset engine positions.
- 1/2 sets are available for crash replacement.
- Ceramic coating services are available. Call Dynatech® for details.
- 1 Year Limited Warranty.



| DESCRIPTION | TUBE SIZE | COLL. | H.P. | INTERCHANGE # | PART # |
|--------------|-----------|--------|---------|---------------|-----------|
| SPORT/ B MOD | 1.625" | 3.000" | 300-400 | 1185V | 701-17610 |

TORQUE BOOSTERS

The Dynatech® Torque Booster is a great way to pick up some low end torque on many engines. The gains are usually between 2500 and 4200 rpm, which is an excellent benefit for restarts. This device is a simple way to quickly add that well needed torque on the low end without sacrificing any power on the top end.

- Easy install.
- Excellent add-on for crate engines.
- Increased torque on restarts.
- Promotes torque gains of 10% or more.



| APPLICATION | MATERIAL | INLET SIZE | OUTLET SIZE | PART # |
|-------------------------------------|-----------------|------------|-------------|-----------|
| TORQUE BOOSTER (602 & 604 Engines) | MILD STEEL | 3.000" | 3.000" | 772-06312 |
| TORQUE BOOSTER (500-600 HP Engines) | MILD STEEL | 3.000" | 3.500" | 772-06302 |
| TORQUE BOOSTER (600+ HP Engines) | MILD STEEL | 3.500" | 3.500" | 772-06352 |
| TORQUE BOOSTER (602 & 604 Engines) | STAINLESS STEEL | 3.000" | 3.000" | 772-06322 |

CRATE CHEVY STREET STOCK

CHEVY CHASSIS HEADERS

MADE IN THE U.S.A.

- Special Flange fits Standard Chevy and 602 Crate.
- Engineered for **602 Crate** engines.
- Gaskets and bolts included.
- Fits GRT, NASCAR LMS, Shaw, Sport Mods IMCA Sport Mods and most IMCA Modifides.
- Number 1 spark plug should be at least 1.000" behind ball joint.
- 1/2 sets available.
- Ceramic coating services are available. Call Dynatech® for details.
- 1 Year Limited Warranty.



IMCA Southern Sportmod Legal

| DESCRIPTION | TUBE SIZE | COLL. | INTERCHANGE # | PART # |
|-----------------------------------|-----------|--------|---------------|------------------|
| STANDARD CHEVY & 602 CRATE | 1.625" | 3.000" | 151 & 151CM | 701-10010 |

CHEVY STOCK CLIP HEADERS

MADE IN THE U.S.A.

- Fits standard Chevy engines with angle or straight plug heads.
- Gaskets and bolts included.
- Collectors exit over rails on stock front clip cars.
- 1/2 sets available.
- Ceramic coating services are available. Call Dynatech® for details.
- 1 Year Limited Warranty.



| DESCRIPTION | TUBE SIZE | COLL. | H.P. | INTERCHANGE # | PART # |
|-----------------------------------|----------------|--------|---------|---------------|------------------|
| STANDARD CHEVY & 602 CRATE | 1.625" | 3.000" | 350-400 | 155 & 155CM | 701-19210 |
| STANDARD CHEVY | 1.625"- 1.750" | 3.000" | 400-450 | 155V & 155VCM | 701-29210 |

CHEVY STREET STOCK

**CAMARO ('70 -'81) • MALIBU, MONTE CARLO,
GRAND PRIX, CUTLASS, BUICK REGAL ('72 -'87)**

MADE IN THE U.S.A.

- Fits standard Chevy engines with angle or straight plug heads.
- Gaskets and bolts included.
- Engine must be in stock location.
- *Won't clear stock manual clutch linkage ball, factory air conditioner box, rear or side engine mounts.*
- Must use short oil filter.
- 1/2 sets available.
- Ceramic coating services are available. Call Dynatech® for details.
- 1 Year Limited Warranty.



| DESCRIPTION | TUBE SIZE | COLL. | H.P. | INTERCHANGE # | PART # |
|----------------|-----------------|--------|---------|---------------|-----------|
| STANDARD CHEVY | 1.625" - 1.750" | 3.000" | 400-450 | 185V & 185VCM | 701-31910 |
| STANDARD CHEVY | 1.750" | 3.500" | 450+ | 186 & 186CM | 701-22010 |

CRATE DIRT LATE MODEL

BARRY WRIGHT • MORRIS • ROCKET • SWARTZ
 • OTHERS W/ 2.625" OFFSET & 6.000" SETBACK



MADE IN THE U.S.A.

- Unique flange design fits standard Chevy and 602 Crate heads with a single part number.
- 604 Crate available in port matched mild steel or Stainless Steel.
- Increase Torque with Extension Kits and Torque Boosters sold in kits. (see p.72)
- Machine surfaced flanges – no leaks.
- 1/2 sets available.
- 1 year limited warranty.



| DESCRIPTION | TUBE SIZE | COLL. | PART # |
|--|---------------|--------|------------------|
| 604 CRATE - STAINLESS STEEL ULTIMATE TORQUE PACKAGE** | 1.625"-1.750" | 3.000" | 711-65810 |
| 604 CRATE - STAINLESS STEEL HEADERS / EXTENSION KIT* | 1.625"-1.750" | 3.000" | 711-55810 |
| 604 CRATE - STAINLESS STEEL HEADERS | 1.625"-1.750" | 3.000" | 711-45810 |

**Includes Headers, Extension Kit, and Torque Boosters
 *Includes Headers, 80° Elbow & 14.000" Extension Pipe.

FAST • GRT • SHAW • TRAKSTAR
 • OTHERS W/ 0.625" OFFSET & 6.000" SETBACK



MADE IN THE U.S.A.

- Unique flange design fits standard Chevy and 602 Crate heads with a single part number.
- 604 Crate available in port matched mild steel or Stainless Steel.
- Increase Torque with Extension Kits and Torque Boosters sold in kits. (see p.72)
- Machine surfaced flanges – no leaks.
- 1/2 sets available.
- 1 year limited warranty.



| DESCRIPTION | TUBE SIZE | COLL. | PART # |
|--|---------------|--------|------------------|
| 604 CRATE - STAINLESS STEEL ULTIMATE TORQUE PACKAGE** | 1.625"-1.750" | 3.000" | 711-66410 |
| 604 CRATE - STAINLESS HEADER / EXTENSION KIT* | 1.625"-1.750" | 3.000" | 711-56410 |
| 604 CRATE - STAINLESS HEADER | 1.625"-1.750" | 3.000" | 711-46410 |

**Includes Headers, Extension Kit, and Torque Boosters
 *Includes Headers, 80° Elbow & 14.000" Extension Pipe.

CRATE DIRT LATE MODEL

**BERNHEISEL • LAZER • MASTERSBILT
• RAYBURN • WARRIOR**

MADE IN THE U.S.A.

- Unique flange design fits standard Chevy and 602 Crate heads with a single part number.
- 604 Crate available in port matched mild steel or Stainless Steel.
- Increase Torque with Extension Kits and Torque Boosters sold in kits below.
- Machine surfaced flanges – no leaks.
- 1/2 sets available.
- 1 year limited warranty.



| DESCRIPTION | TUBE SIZE | COLL. | PART # |
|--|---------------|--------|------------------|
| 604 CRATE - STAINLESS STEEL ULTIMATE TORQUE PACKAGE** | 1.625"-1.750" | 3.000" | 711-65910 |
| 604 CRATE - STAINLESS STEEL HEADERS / EXTENSION KIT* | 1.625"-1.750" | 3.000" | 711-55910 |
| 604 CRATE - STAINLESS HEADER | 1.625"-1.750" | 3.000" | 711-45910 |

*Includes Headers, 80° Elbow & 14.000" Extension Pipe.
**Includes Headers, Extension Kit, and Torque Boosters.

COLLECTOR EXTENSIONS

14" EXTENSIONS



- Designed for use with crate engines.
- Equalizes crate engine exhaust system when used with 80° elbow.



80° ELBOW EXTENSION

- Designed for use on driver's side dirt late model headers.
- Used to route exhaust toward rear of car.

————— PURCHASE 604 CRATE ACCESSORIES INDIVIDUALLY —————

| APPLICATION | PART # | APPLICATION | PART # |
|-----------------------------|------------------|---------------------------|------------------|
| 14.000" EXTENSION | 780-00314 | 80° ELBOW | 780-80301 |
| 14.000" STAINLESS EXTENSION | 780-01314 | 80° ELBOW STAINLESS STEEL | 780-80311 |

TORQUE BOOSTERS

The Dynatech® Torque Booster is a great way to pick up some low end torque on many engines. The gains are usually between 2500 and 4200 rpm, which is an excellent benefit for restarts. This device is a simple way to quickly add that well needed torque on the low end without sacrificing any power on the top end.



- Easy install.
- Excellent add-on for crate engines.
- Increased torque on restarts.
- Promotes torque gains of 10% or more.

| APPLICATION | INLET SIZE | OUTLET SIZE | PART # |
|--------------------------------------|------------|-------------|------------------|
| TORQUE BOOSTER (602 & 604 CRATE) | 3.000" | 3.000" | 772-06312 |
| TORQUE BOOSTER (500-600 HP Engines) | 3.000" | 3.500" | 772-06302 |
| TORQUE BOOSTER (600+ HP Engines) | 3.500" | 3.500" | 772-06352 |
| TORQUE BOOSTER STAINLESS STEEL (604) | 3.000" | 3.000" | 772-06322 |

PAVEMENT LATE MODEL

ECONOMY CHEVY CROSSOVER HEADER

- Non-equal length design gives flat torque curve for slick tracks.
- Valve covers can be removed with header installed.
- 21.000"-28.000" primary length.
- Excellent economy header.
- Ceramic coating services are available.
Call Dynatech® for details.
- Gaskets & bolts included.



| TUBE SIZE | COLLECTOR | H.P | PART # |
|-----------------|-----------|---------|-----------|
| 1.625" - 1.750" | 3.000" | 400-550 | 701-24510 |

TORQUE BOOSTERS

The Dynatech® Torque Booster is a great way to pick up some low end torque on many engines. The gains are usually between 2500 and 4200 rpm, which is an excellent benefit for restarts. This device is a simple way to quickly add that well needed torque on the low end without sacrificing any power on the top end.



- Easy install.
- Excellent add-on for crate engines.
- Increased torque on restarts.
- Promotes torque gains of 10% or more.

| APPLICATION | INLET SIZE | OUTLET SIZE | PART # |
|-------------------------------------|------------|-------------|-----------|
| TORQUE BOOSTER (602 & 604 CRATE) | 3.000" | 3.000" | 772-06312 |
| TORQUE BOOSTER (500-600 HP Engines) | 3.000" | 3.500" | 772-06302 |
| TORQUE BOOSTER (600+ HP Engines) | 3.500" | 3.500" | 772-06352 |

