

DPI Performance Racing Products

DPI

Volume: 8

PERFORMANCE RACING PRODUCTS

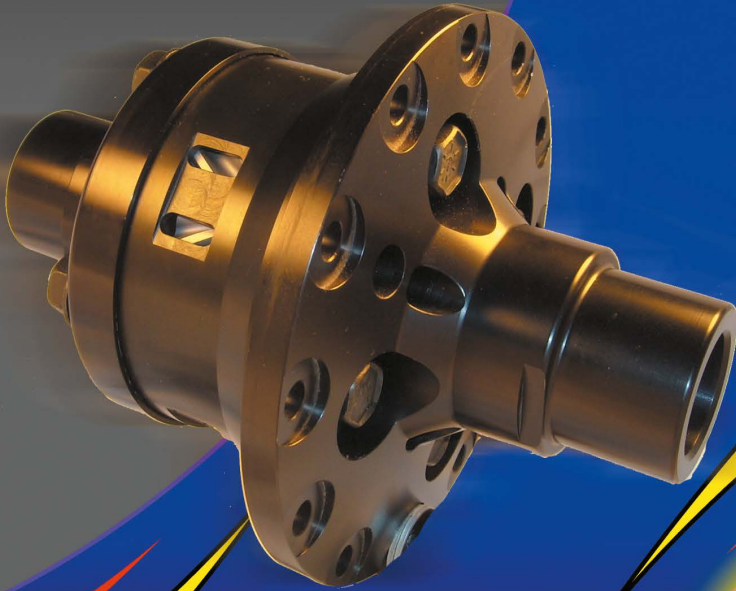

PLATINUM TRACK
DIFFERENTIAL

THE STORY BEHIND DPI PERFORMANCE RACING PRODUCTS



“The seed for my racing career was planted over 40 years ago by my father. He brought home a quarter midget and from that moment on I have been dedicated to the sport of auto racing. In the early seventies I was developing innovative products along with a racing career that includes 100’s of short track wins and several championships.”



“Developing products that really work has been the driving force behind the success of DPI. Every racer has bought parts that didn’t live up to their expectations or didn’t perform as promised. Personally, I feel racers design the best products; they know what works! I have taken the experiences from my racing career and created a company that puts the racer first.”

- DAN PRESS -

Randy Larsen began his driving career in 1985 at the wheel of a 1969 Chevelle Street Stock. After honing his driving skills in the car for two seasons at Petaluma Speedway, he moved up to the very popular new IMCA Modifieds. Randy achieved his goal of winning the IMCA Modified Championship in 1992. It was a hand fought victory; made especially sweet due to the close second place finishes in previous years for the Northern California driver.

In 1994 Larsen moved from the high banked clay oval at Petaluma, to the paved ovals where he competed against some of the best drivers in the Bay Area. Randy moved up to the ultra competitive late model stock cars in 1996, where he competed in the NOR-CAL “Best of the West” Series. Larsen had a very successful season, winning at All American Speedway in Roseville and finishing fourth in season points. He also won the prestigious “Rookie of the Year” title and competed in the NASCAR Featherlite Southwest Series in 1999.

Prior to starting Larsen Racing Products, Randy ran his own automotive shop, Automotive Specialties, for four years.

Seeing a need for quality performance racing products in the industry, Randy founded Larsen Racing Products. Starting from the ground up, Randy has successfully owned and operated LRP for over thirteen years. Randy Larsen caters to the top racing teams locally and nationwide and understands well the rigors of running at the top like the competitive NASCAR Featherlite Southwest Series.

In 2003, Randy once again had seen need for quality products and wanted to design the best for racing. In his search Randy purchased Dan Press Industries to begin manufacturing his own performance parts. Randy Larsen and Dan Press had a similar vision; they both wanted to develop products that really lived up to the racers expectations and Randy is accomplishing this vision everyday with the products he develops today.

A top performer on and off the track, Randy Larsen brings his business and racing expertise to assist you in fulfilling all of your performance racing product needs.



- RANDY R. LARSEN -



A BIG THANK YOU TO MY FRIENDS
FOR ALL OF YOUR HARD WORK
THROUGHOUT THE YEARS!
(NOT PICTURED, KEN JOHNSON)



PRODUCT INDEX & WARRANTY

Page 4.....	New Products
Page 8.....	The New Platinum Track Differential & Service Parts
Page 9.....	The Black Gold Differentials & Service Parts
Page 10.....	Liquid Cooled/Self Bleeding Brake Fluid Recirculator
Page 11.....	Sure Stop I
Page 12.....	Sure Stop II
Page 13.....	Lock Resistant Brake System (LBS)
Page 14.....	Rear End Brackets
Page 15.....	Accessories
Page 18.....	Gauges
Page 19.....	Hub Assemblies
Page 20.....	The New Series 71 Caliper
Page 21.....	Rotors & Gears
Page 22.....	Brake Pads & Brake Accessories
Page 25.....	Quarter Midget & Aluminum Tanks
Page 26.....	Sure Stop I Installation Instructions
Page 27.....	Sure Stop II Installation Instructions
Page 28.....	Platinum Track Differential Recommendations
Page 29.....	Platinum Track Installation Instructions
Page 30.....	Black Gold Installation Instructions
Page 31.....	Tools For Measuring Preload Diagram

Warranty/Returns: There is no warranty or guarantee of liability, either expressed or implied, written or oral, applicable to DPI Performance Racing Products. The user assumes all responsibility and liability arising from malfunction, damage, or misuse. Any product suspected of being defective must be returned freight prepaid for inspection.

All sales are considered final. Authorization must be obtained before returning any merchandise. A 20% restocking fee will be charged on all special orders and/or non-stocking orders. Authorization to return and acceptance of any and all returned items is at the sole discretion of DPI. A credit will be issued for the returned items only. No returns accepted after thirty days. All unauthorized returns, or those shipped freight collect, will be refused and returned to sender.

Prices are in U.S.A. dollars and are subject to change without notice. Prices are suggested prices only and possession of a price list does not guarantee the purchaser the prices therein.

Terms of Sale: All new accounts are on a C.O.D, Certified Check, or Money Order only basis until the proper credit information has been filled out and approved to accept checks. If at any time a check is returned "NSF" the account will be automatically placed on C.O.D, Certified Check, or Money Order only basis and will be turned over for collection if it is not returned to a "Paid in Full" status immediately. DPI accepts VISA, MasterCard, and Discover. Credit applications are available upon request. Any accounts past due are subject to a 1.5% finance charge which will be added to your monthly statement. There is a \$10.00 drop ship fee for orders not shipped directly to you.

Delivery/Freight: Orders received by 1:00 p.m. can usually be shipped the same day with the exception of custom orders and out of stock merchandise. Please specify UPS Next Day Air, Second Day Air, Three-day Select, or Ground when ordering. Larger orders can be palletized and shipped via specified common carrier. You will be notified of any delay or back order and informed of an expected delivery date. We try to avoid back orders; However, it occasionally does occur and your patience is greatly appreciated. All merchandise shipped by DPI is F.O.B., Petaluma, Ca.

Refused Shipments: Any shipment that is refused without authorization will be subject freight charge backs and handling fees. DPI Performance Racing Products, Inc. products are for racing purposes only, not for street or highway use.



The New Platinum Track Differential is a torque bias gear driven differential, developed specifically for racing.
See Page 8



The New Ultimate AN Wrench has a stainless steel insert for added strength. Features a compact, light-weight and thin design.
See Page 15

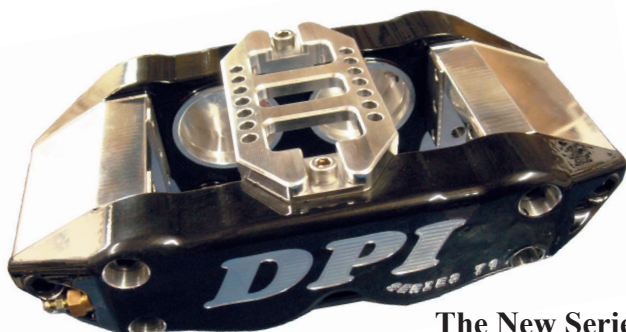

The New Series 71 Caliper Line Features an integral locking design to reduce caliper flex.
See Page 20

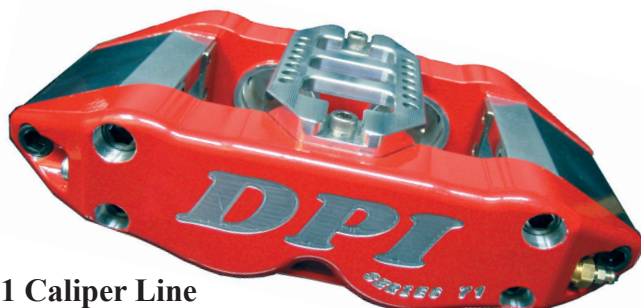

The New Spindle Adapter Here is a quick way to check your bump steer using this great tool!
See Page 17

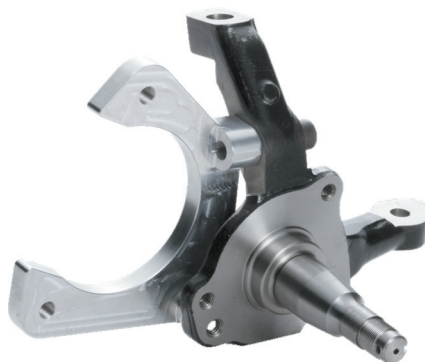

The Billet Aluminum Pinto GM Metric Caliper Bracket This bracket is strong and helps eliminate flex experience with steel brackets.
See Page 22

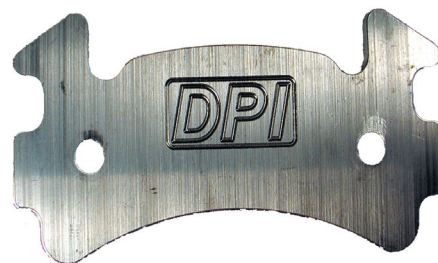

The Billet Aluminum Pinto GM Metric Brake Pad Spacer Especially useful with different sized pistons where puck style spacers will not work.
See Page 22

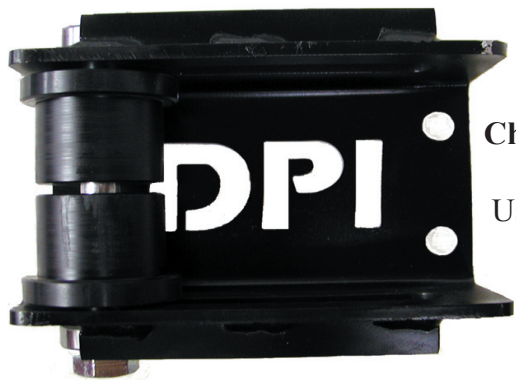

Chevrolet/Camaro Leaf Spring Slider Box
Use in place of shackles
See Page 17



Improved Auto Hub Steering Coupler
DPI's new lightweight auto hub is compact while retaining the same size fine spline as the larger version.
It's also less expensive!
See Page 15



1" Aluminum Water Neck Spacer
1" spacer for SBC has two 1/2NPT and two 3/8NPT threads for cooling lines and gauge fittings.
See Page 17



Metric Adapter
DPI now offers a metric adapter that allows you to check brake pressure on GM metric calipers.
See Page 18



3 Pump 32lb. DPI Warrior Jack
Superior race jack. Made in the U.S.A
See Page 16



360 Degree Gauge
The 360 degree rotation action lets you quickly view the gauge and check your brake pressure from any direction with its swift swivel motion.
See Page 18

8.8" STREET DIFFERENTIAL

DPI is proud to announce its new Ford 8.8 C-clip type differential! This will be a direct replacement to the standard Ford open differential.

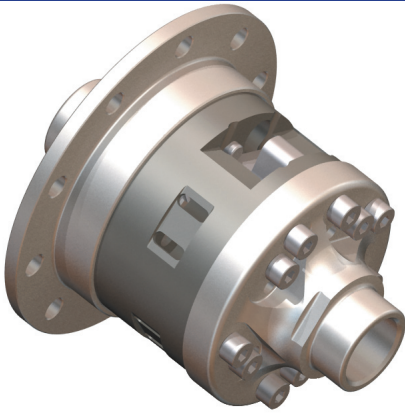

Our all new **USA made** billet differential uses all gears; no plates or clutches, which means no clutches to wear out. This unit has a very smooth operation.

Get the maximum traction with our torque sensing differential; It can sense tire spin and transfer power to the tire with the most grip.

8.8" Differential

With today's horsepower and torque, you need a differential with the DPI strength and dependability. We use only the best gear material made from aircraft grade 9310 steel then have it heat treated to our specifications. We use four pinions per side. This differential is capable of handling horsepower up to 750+.

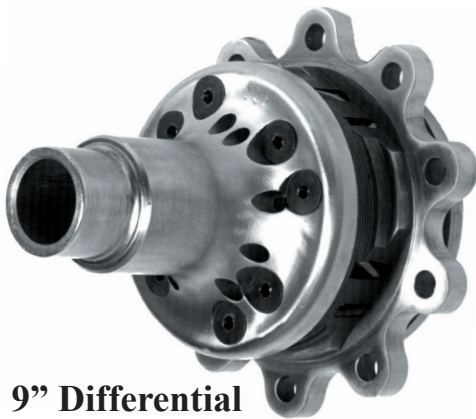

9" Differential



Great for drag racing!

Get the same high quality and performance as our race differentials with our new street differential. These non-preloaded differentials are essential for everyday driving and performance. These differentials have no drag and are all gear driven posi. They are available in 8", 9", Supermax, 8.8 IRS, and Quick Change.





THE NEW PLATINUM TRACK DIFFERENTIAL

The Black Gold has been redesigned and is now called the Platinum Track Differential. This all new pre-load design will withstand the punishments of today's horse power and technological advances.

Unsurpassed quality and performance will take you to the winner's circle. The newly designed Platinum Track will leave the competition in the dust. Developed by racers, for racers - it is specifically engineered to hold-up under the most extreme conditions.

WHAT IS THE PLATINUM TRACK AND WHAT DOES IT DO?

The Platinum Track is a torque bias gear driven differential, developed specifically for racing. It will allow you to go through the corners faster using less stagger.

WHAT IS WRONG WITH A SPOOL OR LOCKER?

In a turn, a spool drives the front of the car straight toward the wall (a push). A locker provides some differential action entering a turn, but as soon as power is applied, it locks up and is no better than a spool. With the rear wheels locked together, the only way to make the car turn is with stagger. Stagger is at best a compromise - just ask anyone who has lost a race when their stagger went away.

WHAT IS THE PLATINUM TRACK'S ADVANTAGE OVER A LOCKER?

The Platinum Track torque bias differential allows a car to turn easily into and roll freely through the turn - it never locks up when power is applied. This is due to the gears used (not springs or clutches) to direct the power to the wheel with the most traction.

HOW DOES THE PLATINUM TRACK WORK?

The axles are connected to the ring gear by special spiral gears that are made in such a way they sense which tire has the most resistance (traction) and smoothly delivers power to it. The gears operate on the same principle as a steering pinion: you can turn the steering shaft easily, but not the steering arm. The tire with traction instantaneously receives power in direct relation to the amount of traction. For instance, there is no notchiness or "hunting" when accelerating off a corner: the power goes down smoothly.

WHAT MAKES THE PLATINUM TRACK THE BEST HIDDEN SECRET IN THE MARKET?

The axle gears have a preload on them. What does this mean to the racer? You can drive in deep, and not have the loose entry feel of most open, or non-loaded differentials. The preload is factory set. The Platinum Track with the correct amount of preload will let you roll through the center of the corner with greater speed and your exit speed will also be faster. All of this is possible with less stagger, no more dragging excessive stagger down the straight away scrubbing off speed and tires.



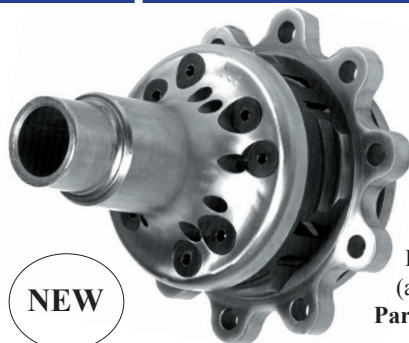

NEW

9" Ford
Platinum Track Differential
(available in 1/4 or 1/2 tight)
Part #s: DPI 1450P - 31" Spline
DPI 1400P - 28" Spline



NEW

8.8" Ford
Platinum Track Differential
(available in 1/4 or 1/2 tight)
Part #s: DPI 1090P-IRS
DPI 1090P - 31" Spline
DPI 1090P - 28" Spline

THE ALL NEW PRE-LOAD DESIGN WILL WITHSTAND THE PUNISHMENT OF TODAY'S HORSE POWER AND TECHNOLOGICAL ADVANCES. UNSURPASSED QUALITY AND PERFORMANCE WILL TAKE YOU TO THE WINNERS CIRCLE. AT DPI WE'RE COMMITTED TO BRINGING YOU NOTHING BUT THE BEST, AND IT SHOWS WITH OUR NEW PLATINUM TRACK.



NEW

Super Max Platinum
Differential
(available in 1/4 or 1/2 tight)
Part # DPI 1200P - 31"Spline



NEW

Quick Change
Platinum Track Differential
(available in 1/4 or 1/2 tight)
Part # DPI 1250P - 31" Spline

All of our differentials are proudly made in the USA

SERVICE PARTS

PLATINUM QUICK CHANGE		9" PLATINUM	
DPI 1251	Flange End Cap	DPI 1401	Long End Cap
DPI 1252	Short End Cap	DPI 1403	Short End Cap
DPI 1004	Drivers	DPI 1404	Wear Plate
DPI 1094	Wear Plate	DPI 1405	Bolts - One Set (16)
DPI 1061P	Right Gear	DPI 1060P	Left Gear
DPI 1062P	Left Gear	DPI 1061P	Right Gear
DPI 1056	Right Pinion	DPI 1056	Right Pinion
DPI 1057	Left Pinion	DPI 1057	Left Pinion

Note: Left side of differential is ring gear side.

DPI recommends in most racing applications the half tight Platinum Track Differential. These units are available in 1/4 tight and 1/2 tight only. Preset at the factory. Contact our technical staff to help determine the correct preload for your application.

LIQUID GOLD FORTIFIER

Liquid Gold Differential Fortifier is a special additive for torque bias differentials. It can reduce break-in and running temperatures by as much as 50 degrees. This fortifier will reduce noise and chatter, and helps increase the life of your differential.

6 oz. bottle
Part # DPI 1300



We Recommend
Joe Gibbs Gear Oil With
Our Platinum Differentials

1qt. bottle
Part # DPI 00630





Quick Change
Black Gold
Differential
Part # DPI 1250 - 31 Spline

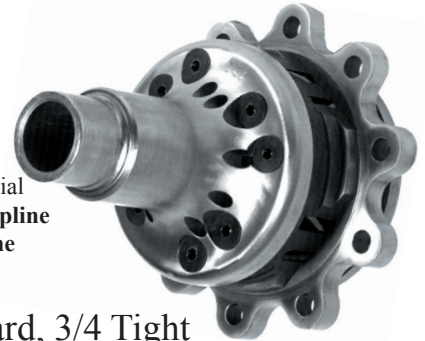

9" Ford
Black Gold Differential
Part # DPI 1450 - 31 Spline
DPI 1400 - 28 Spline

The Black Gold differentials are available in Standard, 3/4 Tight and Full Tight, preset at the factory.

Contact our technical staff to help determine the correct preload for your application.



Part # DPI 1200
Super Max Black Gold
Differential

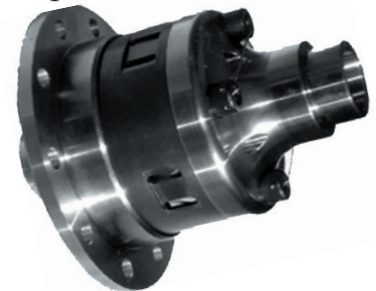

Part # DPI 1090 - 31" Spline
8.8" Ford Black Gold
Differential
(For IRS Part # 1090-IRS)

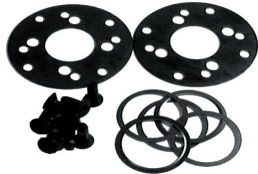

Part # DPI 1410
9" Preload Adjusting Kit
All items sold separately.
DPI 1405 for Bolts
DPI 1404 Wear Plate

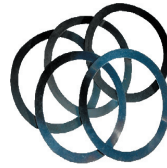

PART NO.	DESCRIPTION
DPI 1022	Quick Change Shim Pack. 5 per pack. For carrier bearing
DPI 1023	Adjusting Shim Pack 5 per pack. Works for all Black Golds: 8.8", 9" QC, Supermax



Part # DPI 1058SP
Axle Gear (Left)
Fits QC, 9", *.8" & Super Max
Note: Specify Side - Left or Right and type of differential



PART NO.	DESCRIPTION
DPI 1020	Carrier Bearings - 2 per pack
DPI 1021	QC Carrier Setup Bearings .005 oversize
DPI 2949	9" Carrier Bearings



Differential Cooler
Pump
Part #40-524



Part # DPI 1056SP
Pinion (right)

SERVICE PARTS			
QUICK CHANGE		9"	
DPI 1251	Flange End Cap	DPI 1401	Long End Cap
DPI 2152	Short End Cap	DPI 1403	Short End Cap
DPI 1004	Drivers	DPI 1404	Wear Plate
DPI 1094	Wear Plate	DPI 1405	Bolts (one Set)
DPI 1058SP	Right Gear	DPI 1058SP	Right Gear
DPI 1059SP	Left Gear	DPI 1059SP	Left Gear
DPI 1056	Right Pinion	DPI 1056	Right Pinion
DPI 1057	Left Pinion	DPI 1057	Left Pinion
DPI 1042	Harden Washer (8)		
DPI 1010	Short Bolts		
DPI 1011	Long Bolts		

Note: left side of Differential is ring gear.



Lock Up Plug
Fits 9" or Quick Change 31
Spline Only. Black Gold only.
Part # DPI 1025



Liquid Gold Fortifier
Part # DPI 1300
6 oz. bottle

Part # DPI 5820:
We Recommend
Red Line Heavy Shock
Proof Gear Oil with
Black Gold Differentials





Part # DPI LC-SB

FEATURES:

- Self Bleeding
- Reduces O-ring failure
- Dissipates caliper heat
- Purges air from the brake system
- Reduces brake rotor temperature
- Reduces brake pad wear
- Maintains a firm brake pedal
- Works with all existing calipers

The DPI Liquid Cooled/Self Bleeding Brake System cools the caliper by circulating a large volume of brake fluid through the calipers. Caliper heat is dissipated through cooling lines installed between the calipers and the master cylinder. Air is purged from the system as the fluid is circulated. The vehicle maintains a firm brake pedal and cool calipers. Brake rotor temperature and pad wear is further reduced because the driver no longer has to pump the brakes to compensate for a soft pedal caused by air in the system.

LC/SB PLUMBING

diagram 1

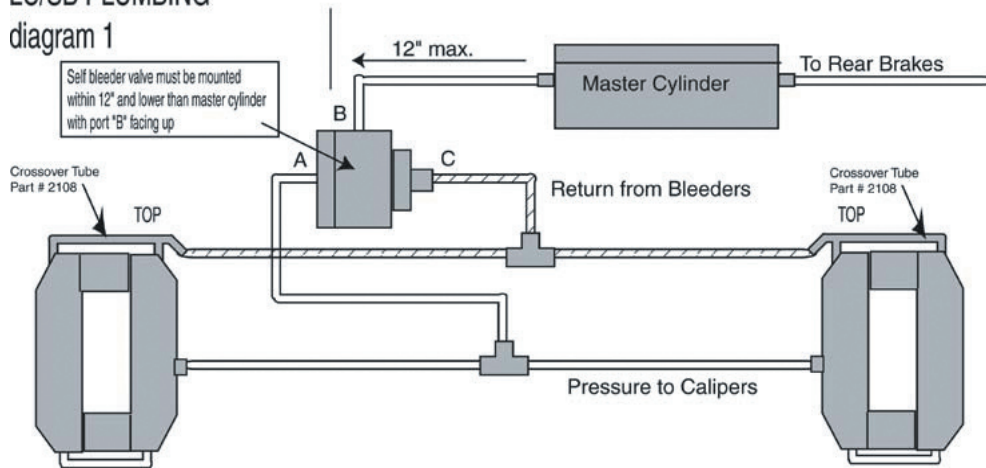

Tech Note: Inspect fluid in master cylinder reservoir. If discolored, drain fluid and re-fill.

LC/SB PLUMBING

(maximum cooling)

diagram 2

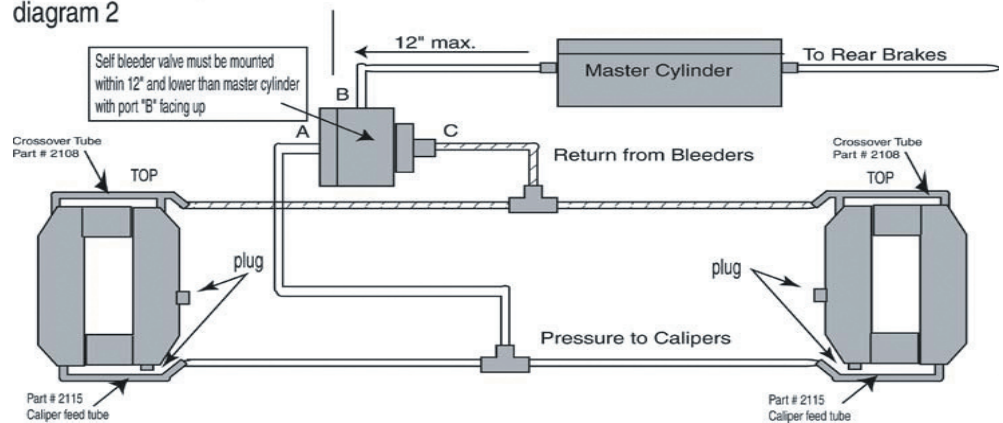

Tech Note: We can custom make cross over tubes for you. Just send us your brake caliper for proper fitting.

You can't go fast if you can't slow down!

The "Sure Stop" Self-Bleeding Recirculator is our easiest to install brake fluid recirculator. The "Sure Stop" continuously circulates the brake fluid through the caliper and back to the master cylinder to eliminate heat build-up in the rotors which causes brake fluid to boil in the calipers. It features a built in safety factor, a closed loop system which helps to prevent brake loss like an open line return system can cause. This is a must have for every race. It is also NASCAR approved.

**Do you tend to run out of brakes before the race is over?
Eliminate the problem with the "Sure Stop" Recirculator.**

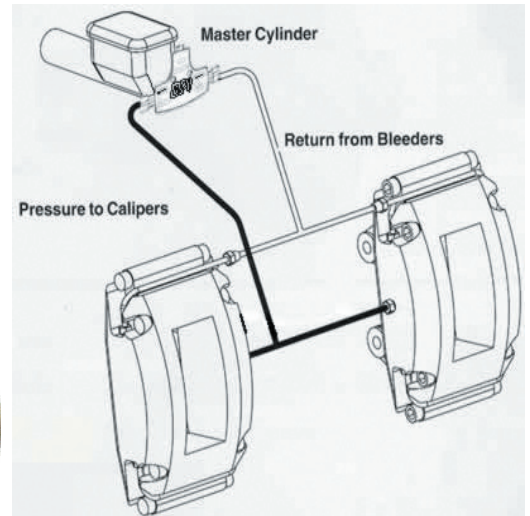
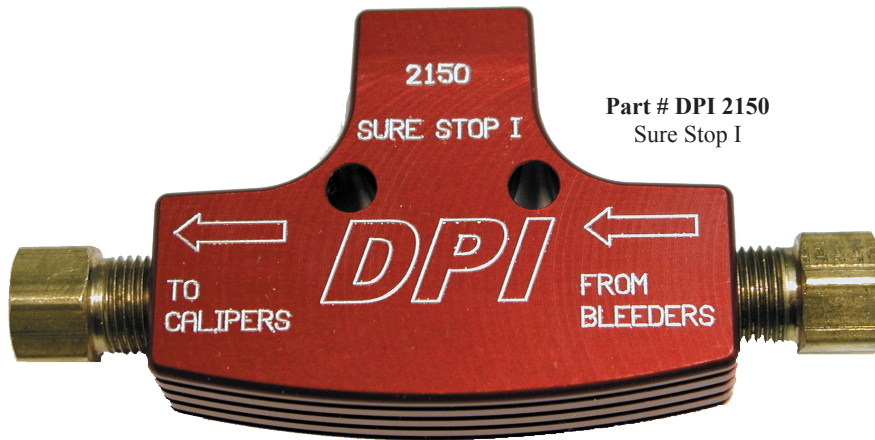

See page 25 for installation instructions

Tech Note: Mount on nose of master cylinder or max 12" from master cylinder.

CROSS OVER TUBES

Crossover tubes are available for most popular calipers. Custom tubes are available, built to your specifications.



NOTE: Comes standard in -3. When ordering special tubes specify rotor width and caliper type.

PART#	DESCRIPTION
DPI 2108	Cross Over Tubes
DPI 2108-4	Cross Over Tubes
DPI 2108-0450 GN	GN Cross Over Tubes
DPI 2108-0460 XL	XL Cross Over Tubes

BRAIDED FLEX HOSE

PART#	DESCRIPTION
DPI 630015	-3 Braided Flex Hose - 15"
DPI 630018	-3 Braided Flex Hose Straight Ends - 18"
DPI 639015	-3 Braided Flex Hose 90 Deg. On One End - 15"
DPI 639018	-3 Braided Flex Hose 90 Deg. On One End - 18"

We offer a large variety of brake lines



The Ultimate Road Course Re-Circulator

When the brake pedal is depressed with a dual master cylinder, the front rod has to travel much farther than the rear, due to the front calipers having much larger pistons, and most cars use a smaller master cylinder for more front brake pressure. This creates a few problems for your brake system.

Problem #1. The rear calipers achieve full pressure before the front calipers, which can cause rear wheel lockup.

Problem #2. The balance bar will try to bind because the front m/c rod is traveling farther. As the race continues the brake balance will change as the front brakes get hotter. The front m/c rod will continue to travel further.

With the development of the Sure Stop II self bleeding brake fluid recirculator and master cylinder equalizer the rear master cylinder feeds the front until the pressure rises, then allows the front and rear master cylinders to balance throughout the entire race, even as the front brakes begin to fade.

BRAKE ACTIVATED KILL SWITCH

With the interest in drivers safety, DPI is offering an optional momentary pressure switch that will disconnect the ignition when line pressure rises approximately 200 psi above normal. The switch will reconnect when the pressure is reduced. We know from our own experience, the only reaction the driver will have for sure is to press harder on the brake pedal. This item is sold separately and can be plumbed directly into the "Sure Stop II", or anywhere in your existing brake system.

NEW FEATURES:

- Balance the front and rear master cylinders.
- Prevents spiking rear calipers before front brake pressure is achieved.
- Reduces excessive pedal travel and prevents over centering of the balance bar.
- Maintains a firm brake pedal without having to adjust the bias during a race.
- Optional pressure switch to kill the engine in the event of a stuck throttle or carburetor, screws directly into the recirculator top port, wires into ignition switch with just two wires.

See Page 11 for
Crossover Tubes



See page 27 for
installation instructions

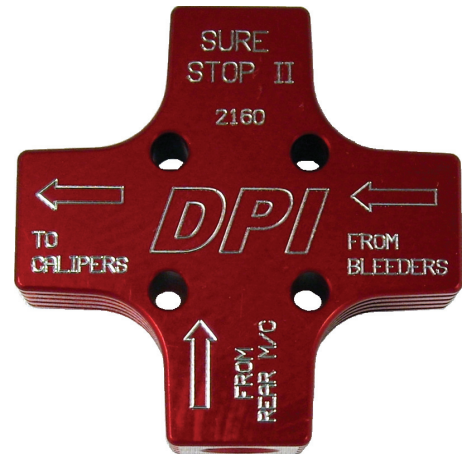

Part #DPI 2160

A MUST FOR YOUR BRAKE SYSTEM

Comes complete with fittings and hardware
(master cylinders are not included)

- Eliminate excessive pedal travel
- Eliminate brake fluid boiling
- Reduce pedal fade and brake loss
- Reduce rear wheel lock up
- Increase caliper O-ring life

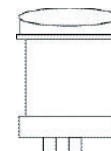

* NOTE: Optional dual
feed reservoir for use in
place of reservoir
balance tube.
Part #DPI 2185

RESERVOIR BALANCE
TUBE
* SEE NOTE

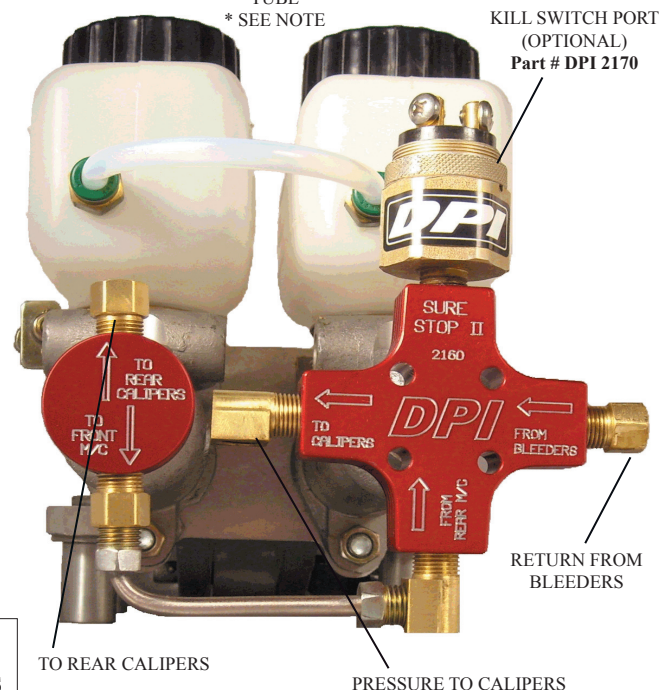

LBS was originally developed for the professional race teams in Nascar to prevent a loose or over steer condition under heavy loads. It assures the front tires slip first by dampening the pressure to the rear brakes. With LBS the rear tires will accept nearly twice as much braking force without locking up.

The LBS installs easily in the rear brake line and utilizes a unique dampening valve that acts as a shock absorber to sense and dampen the sharp spike in-line pressure when the brakes are applied suddenly.

The LBS improves the brake performance on any race car or truck. The DPI LBS doesn't reduce rear brake pressure, it dampens and delays it. It prevents rear brake lock-up without degrading rear brake performance and overloading the front brakes.



Part#: DPI LBS-1

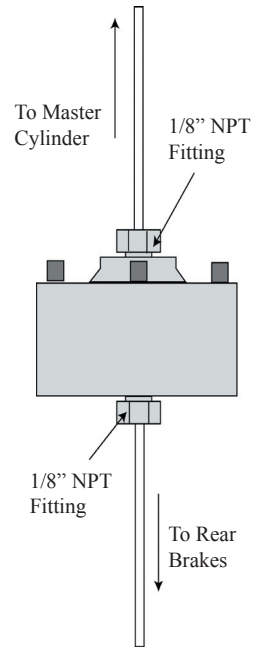

**Now you can use the same
Lock Resistant Brake System
the professional race teams use!**

Tech Note: Install in-line to rear brakes approximately 1" to 12" before it Y's to each rear wheel. Head of the bolts should be facing the ground and that is your inlet side. Use one valve per vehicle. If you use the same piston caliper size for front and rear you will need two LBS's; one in each rear line to caliper.

If system is dry bleed first then install LBS then re-bleed again.

Great for Hot Rods!

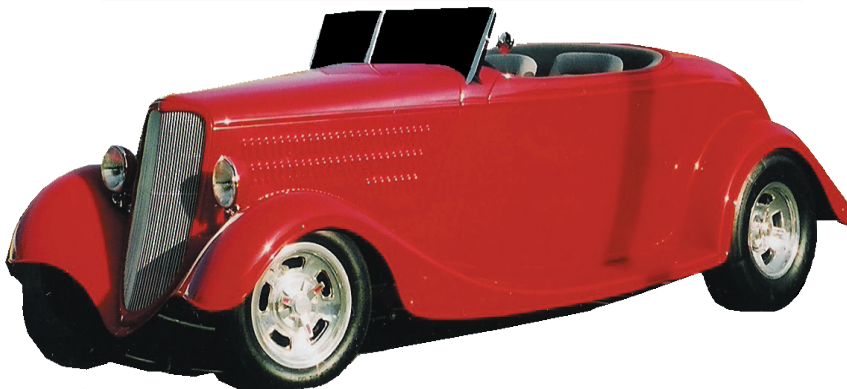

**Why reduce rear brake pressure in your Hot Rod by using a proportioning valve?
Get The Best Brakes With DPI's LBS.**



ALUMINUM TRAILING ARM BRACKET

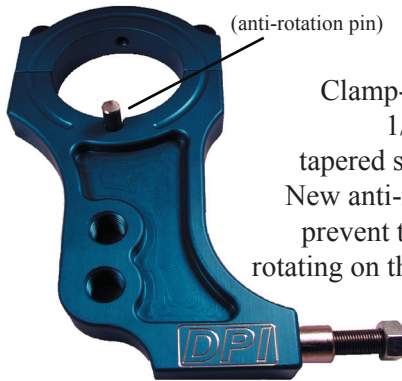

(anti-rotation pin)
Clamp-on bracket with 1/2" grade 8 bolt, tapered sleeve for shock. New anti-rotating pin will prevent the bracket from rotating on the rear end tube.

Part # DPI 2001

ADJUSTABLE PINION MOUNT FOR J BAR

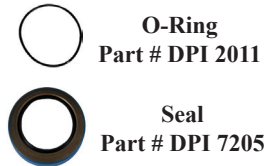

O-Ring
Part # DPI 2011
Seal
Part # DPI 7205

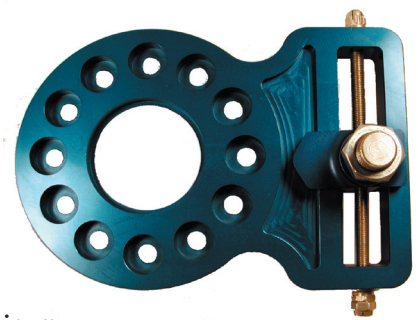

Part # DPI 7600

Made from Billet 6061-T6 aluminum.
Fits most standard quick changes.

LIGHTWEIGHT ADJUSTABLE BRAKE BRACKET

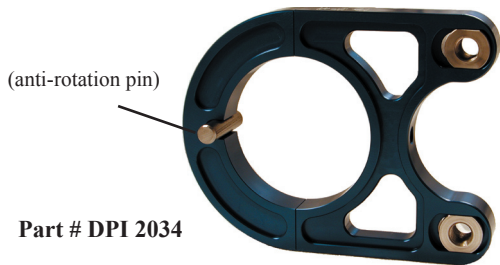

Part # DPI 2034

Part # DPI 2034-NUT
Rotation Pin
Part # DPI 2034-B

Many new features including anti-rotation pin, just tack weld in place. This clamp on bracket allows you to adjust the caliper in and out from 11 3/4 to 12 3/16 dia. rotors, to get the most brake pad contact.

TOP THREE LINK BRACKET



Part # DPI 2040

For standard quick change. Offset holes increase forward bite. (Set of 2)

SERRATED PINION MOUNT J BAR BRACKET



Part # DPI 2010SP

O-Ring
Part # DPI 2011



Serrated Spacer for J Bar
Part # DPI 2013

Seal
Part # DPI 7204



COMBINATION WATTS LINK-PANHARD BAR

Watts linkage can make the car more free through the corner by reducing side load on the rear end, and prevents the rear end from steering the car. Features six holes for changing roll center height easily. Mounts to rear cover of most standard quick changes.

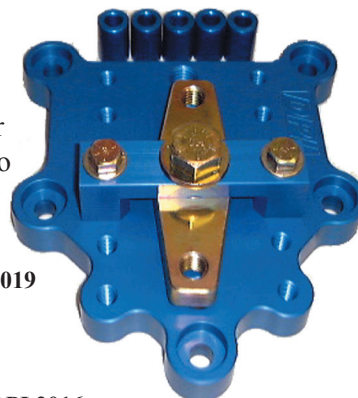

Part # DPI 2019



Part # DPI 2016



Part # DPI 2018



Part # DPI 2017



Part # DPI 2014



REPLACEMENT PARTS

PART#	DESCRIPTION
DPI 2014	STUD
DPI 2016	SWIVEL BAR
DPI 2017	BRONZE BUSHING
DPI 2018	SUPPORT BAR
DPI 2019	SPACER BUSHING

PANHARD BAR SLIDERS

Part # DPI2025 1 3/4" Round

Part # DPI 2030
1" X 2" Rectangular



Multiple use slides are great for bars you don't want to rotate. Both the round and rectangular sliders can be used for panhard bars, trailing arms, and top 3rd link.



AUTO HUB STEERING COUPLERS

With bodies and sliders made of aircraft-quality, 6061 aluminum or steel, the **DPI Auto Hubs** are pin less, and spring-loaded for quick disconnects. The spline steel shaft welds to your steering column.



Part # DPI 2225 Aluminum
Part # DPI 2225S Steel



Part # DPI 2125 Aluminum

DPI's new lightweight auto hub is compact while retaining the same size fine spline as the larger version. It's also less expensive!

COMING SOON!

Steering couplers for collapsible columns.

CAUTION! SPLINES ARE NOT INTERCHANGEABLE!



Part # DPI 2225-Spline 3/4"
Part # DPI 2225-Spline 5/8"



Part # DPI 2225-Spline 3/4"
Part # DPI 2225-Spline 5/8"

ALUMINUM MSD CLAMP

Part # DPI 7000

This one piece clamp allows you to remove and replace the MSD without changing the timing.



ALUMINUM MAGNETO & HEI CLAMP

Part # DPI 2501

This one piece clamp allows you to remove and replace the magneto without changing the timing.

THE NEW ULTIMATE AN WRENCH SET



Try the New DPI Ultimate AN Wrench with a steel insert. Features a compact, light-weight, thin design. Multi-colored, individually marked for easy visual distinction.



PART #	DESCRIPTION
DPI 7503	-3 AN Wrench
DPI 7504	-4 AN Wrench
DPI 7505	AN Wrench Set -6 thru -16)
DPI 7506	-6 AN Wrench
DPI 7508	-8 AN Wrench
DPI 7510	-10 AN Wrench
DPI 7512	-12 AN Wrench
DPI 7516	-16 AN Wrench
DPI 7520	-20 AN Wrench

NEW LIGHTWEIGHT STEERING WHEEL SPACERS



PART #	DESCRIPTION
DPI 7009	1/4" Spacer
DPI 7010	1/2" Spacer
DPI 7011	3/4" Spacer
DPI 7012	1" Spacer
DPI 7013	2" Spacer



3 PUMP 32 LB. DPI WARRIOR JACK

Are you tired of your import junk breaking down?
Go back to using quality products that are American made.
Our 3 pump 32 lb. Warrior Jack is made in the U.S.A.

NEW



Part # DPI 7135

QUICK LIFT JACK OIL

For faster lifting action without foaming. Specially formulated for aluminum jacks. Helps prevent corrosion.

*NOTE: Change jack oil every three months for optimum performance.



Part# DPI 2000

TAPER SPACER FOR ROD ENDS



PART #	DESCRIPTION
DPI 7142	1/2 Taper Spacer
DPI 7143	5/8 Taper Spacer
DPI 7144	3/4 Taper Spacer
DPI 7145	3/4 to 5/8 Taper Spacer Reducer
DPI 7146	5/8 to 1/2 Taper Spacer Reducer



HIGH SPEED PIT SOCKET
Designed for quick pit stops. Heat treated for long wear.
Part# DPI 2504

STABILIZER TIRE VALVE

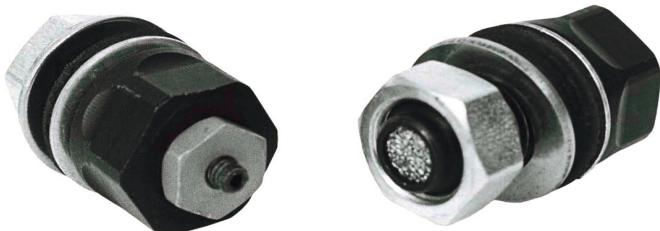

The DPI Stabilizer is the original. The entire top of the valve releases air, so it will blow off faster and shoots down quicker. Can be adjusted from 5 to 50 psi.

Part # DPI 2525

ALUMINUM SKID PLATE

Available for all Magnum Jacks. Great for dirt application. Still allows the front roller to operate.

Part# DPI 1109



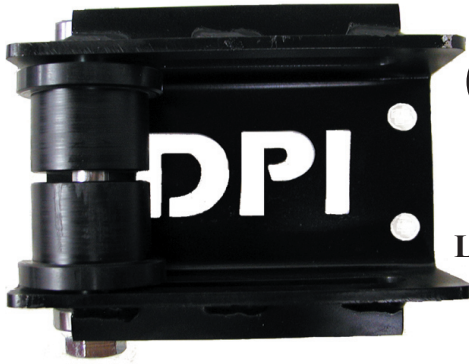

NEW

Chevrolet/Camaro Leaf Spring Slider Box

Use in place of shackles
Sealed roller bearings to prevent binding Delron bushing for long life

Part#: DPI 7120

REPLACEMENT PARTS

PART #	DESCRIPTION
DPI 7121	Bearings for Slider
DPI 7124	Delron Bushing
DPI 7125	Bolt and Nut



Part # DPI 7126

Weld on plate for leaf spring box

NEW



Part#: DPI 7130

DPI SPINDLE ADAPTER

Here is a quick way to check your bump steer using our new DPI Spindle Adapter. Remove spindle nut and screw spindle adapter directly onto the spindle. Now your bump steer plate will bolt directly onto the spindle adapter. Also, the spindle adapter works great for checking rear-end alignment. Simply put a straight edge on the face of the spindle adapter on both sides, and measure.

1" Aluminum Water Neck Spacer

1" spacer for SBC has two 1/2NPT and two 3/8NPT threads for cooling lines and gauge fittings. Recessed slot for water restricter. Includes two O-rings.

NEW



Part # DPI 7460

Utility Jug Filler

Unique new design is capable of emptying 5 gallons in about 20 seconds. Quick seal shuts off flow to prevent leaks. Internal vent means no opening of alternative vents. Requires cap to be threaded to 1"NPT. Flow is slowed when tank reaches capacity to prevent over filling. Available in two sizes. The small neck fits up to a 2.4" opening for most small diameter fuel necks including most quads, dirt bikes, and lawn mowers. Large diameter neck fills up to a 4" opening for late model side fillers and fuel cell openings with the "D" style bail handle caps.

NEW



PART #	DESCRIPTION
DPI 7850S	Small Filler
DPI 7850L	Large Filler
DPI 7855	Filler Jug Cap



NEW

360° ROTATING FLUID FILLED BRAKE PRESSURE GAUGE

We have incorporated a bleeder to give a more accurate reading. You get precise readings every time!

Easy to install because it screws directly into the brake caliper bleeder. The **360° Rotation Action** lets you quickly view the gauge and check your brake pressure from any direction with its swift swivel motion. This great new tool makes checking brake pressure easier with the No-hassle brake pressure adapter.

Options: for AP Calipers and Alcon use adapter DPI 7113



Part# DPI 7110



Fits Wilwood, JFS, Outlaw and Sierra

Part# DPI 7111

NEW



METRIC ADAPTER

DPI now offers a metric adapter that allows you to check brake pressure on GM metric calipers. Just remove the bleeder screw and install the adapter. Now your pressure gauge will screw directly into the adapter. This adapter will swivel to make the installation a breeze.

Part# DPI 7115

All DPI fluid-filled pressure gauges contain silicone, rather than glycerol, which eliminates yellowing and algae growth. Both gauges rate from 0-1500 psi and the dual gauge assembly for in-dash mounting monitors your brakes and front rear.

Part # 012-0617
DUAL GAUGE,
in dash mount



WIDE FIVE HUBS

- High density, high-strength castings with five internal strengthening ribs withstand far greater impacts.
- State of the art stress analysis puts all the weight in just the right places to maintain ultra-lightweight performance.
- Precision machined to tolerances less than 0.0005” ensures consistent fit-up from one part to the next.
- Internal grease retainers keep grease from flowing and collecting in the center of the hub.



Part # 015-0655
ALUMINUM WIDE FIVE HUB
 Aluminum Hub weighs 7.6 lbs.

PART #	DESCRIPTION
015-0600	BEARING KIT
012-0683	INNER BEARING RACE
012-0685	OUTER BEARING RACE
011-0724	WHEEL STUD KIT COARSE (5)
011-1286	DRIVE FLANGE BOLT KIT
SCREWS	DUST CAP SCREW “PLASTIC”

<p>Part # 015-0657A ALUMINUM DUST CAP</p>	<p>Part # 012-0682 INNER WHEEL BEARING</p>
<p>Part # 015-0660 SCALLOPED DRIVE FLANGE (ALUMINUM)</p>	<p>Part # 012-0684 OUTER WHEEL BEARING</p>
<p>Part # 012-0668 GREASE SEAL W-5</p>	<p>Part # 2810 W-5 LOW DRAG SEAL</p> <p>Part # 2205 HUB NUT KIT</p>

FIVE ON FIVE HUB

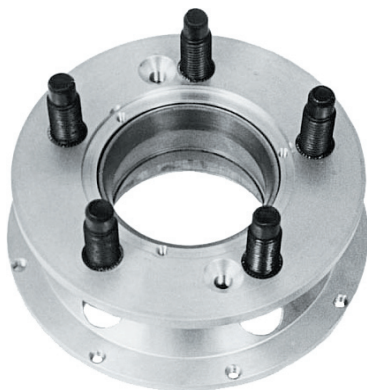

Part # 015-0800

PART #	DESCRIPTION
015-0850	5 ON 5 BEARING KIT
012-0362A	INNER/OUTER BEARING RACE
011-0802	DRIVE FLANGE BOLT KIT
011-0801	DUST CAP BOLT KIT
011-0724	WHEEL STUD KIT COARSE (5)

<p>Part # 012-0800 5X5 GREASE SEAL</p>	<p>Part # 2811 LOW DRAG SEAL</p>	<p>NEW Part # DPI 7450</p> <p>Hollow Aluminum Wide 5 Dust Cap Bolts 7/16” - 14 Thread Removes unneeded weight and attaches with standard wrench.</p>
<p>Part # 015-0801 FIVE ON FIVE DUST CAP</p>	<p>Part # 012-0368A INNER & OUTER WHEEL BEARING</p>	<p>Part # 2205 HUB NUT KIT</p>
<p>Part # 015-0802 ALUMINUM FIVE ON FIVE DRIVE FLANGE Fits all five on five (Howe, Vogel, Port City) type hubs.</p>	<p>Part # 015-8100 RETAINING RING</p>	<p>Part # 910-03914 COARSE LUG NUT</p>
<p>Part # 910-03913 FINE LUG NUT</p>	<p>DPI PERFORMANCE RACING PRODUCTS</p>	

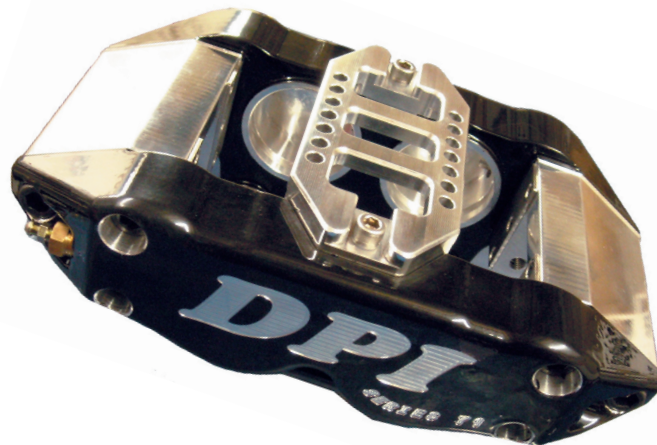
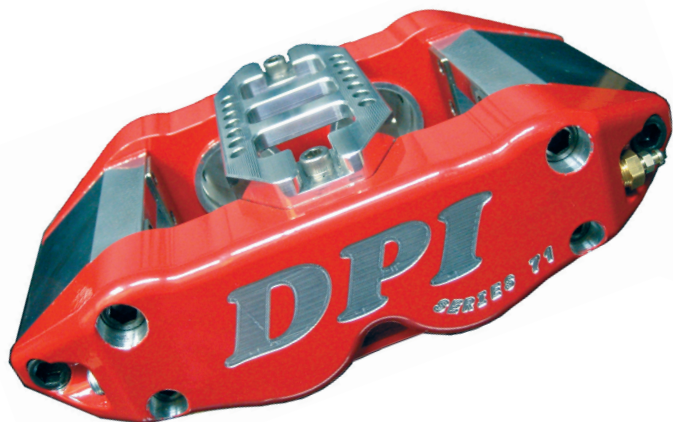

Our calipers are billet for maximum strength

- 3-Bolt design
- 3.5" Mount
- Integral locking design to reduce caliper flex
- Stager piston to reduce brake pad taper
- Stainless steel pistons with high temp sealing O-rings
- Internal crossover fluid passages top and bottom
- Locking bridge support - one of the strongest in the market
- All components are made in the U.S.A.

These calipers are designed by people that know racing.

PART #	PISTON SIZE	ROTOR THICKNESS	REPLACEMENT PISTON	REPLACEMENT SEALS
DPI 71001	1 7/8" - 1 3/4" Stagger	1 1/4"	1 7/8" - 006-0178 1 3/4" - 006-0163	1 7/8" - 007-0178 1 3/4" - 007-0126
DPI 71003	1 3/4"	1 1/4"	006-0163	007-0126
DPI 71005	1 3/4"	.810	006-0163	007-0126
DPI 71007	1 3/8"	1 1/4"	006-0446	007-0981
DPI 71009	1 3/8"	.810	006-0446	007-0981
DPI 71011	1 1/4"	1 1/4"	006-0250	007-0472
DPI 71013	1 1/4"	.810	006-0250	007-0472

When ordering, please specify caliper color.



Part # 7102 Inside Scalloped Only Cast Steel 25 Vane Rotor



Part # 7100 Inside/Outside Cast Steel 25 Vane Scalloped Rotor

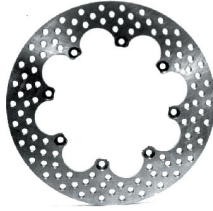

Solid and Drilled Rotors Available



Straight and Directional Vanes Available



SOLID/DRILLED ROTORS

PART #	DESCRIPTION	O.D. (IN.)	THICKNESS (IN.)	I.D. (IN.)	BOLT PATTERN
003-0051-11	25 Vane Vented (Wide 5)	11.750	.810	8.500	8 ON 7.00
003-0053	Cast Steel 25 Vane Scalloped	12.187	.810	8.000	8 ON 7.00
003-0053-11	Cast Steel 25 Vane Scalloped	11.750	.810	8.000	8 ON 7.00
003-1162	Curved Vane (Wide 5)	12.180	1.250	8.440	8 ON 7.00
003-1162-11	Curved Vane (Wide 5)	11.750	1.250	8.440	8 ON 7.00
003-1165	Curved Vane (Hat)	12.180	1.250	9.060	8 ON 7.625
003-0084 D	8 Bolt (Midget)	10.25	.310	6.400	8 ON 6.210
003-0091 D	Solid Wide 5	12.00	.310	8.380	8 ON 7.000
003-0092 D	Solid Wide 5	12.00	.380	8.380	8 ON 7.000
089-2993200401	Left Directional Slotted	11.75	1.25		8 ON 7.000
089-2993200402	Right Directional Slotted	11.75	1.25		8 ON 7.000
229-20-0045-02	Right Directional Vented Slotted	11.75	.810		
299-20-0045-01	Left Directional Vented Slotted	11.75	.810		

Drilled rotors save weight and improve brake response with little or no increase in lining wear. The 10.25" diameter rotors have 120 precision-drilled holes: 5/16" thick rotors are one pound lighter while 3/8" rotors save a full 1 1/4 lb. Drilling is not available on vented rotors. For drilled rotors, add the suffix "D" to the part number.



PART #	STK. HOUSING KITS
R9RMKT	STK. HOUSING BIG BRG. KIT
R9R28MKT	STK. HOUSING SMALL BRG.
R9RSMKT	BIG BRG. BIG HOUSING KIT



Part # 4105 Solid Spacer & Shim Kit (8.8 & 9")

Part # WAA4663 9" Shim Kits



PART #	DESCRIPTION
700-010-01	FORD 9" STORAGE CASE VERTICAL
700-009-01	FORD 9" STORAGE CASE HORIZONTAL

DPI GEARS	
PART #	DESCRIPTION
DPI F890430	9" 430 GEAR SET
DPI F890537AX	9" 537 LW GEAR SET
DPI F890529	9" 529 GEAR SET
DPI F890543	9" 543 GEAR SET
DPI F890567	9" 567 GEAR SET
DPI F890543AX	9" 543 LW GEAR SET
DPI F890350	9" 350 GEAR SET
DPI F890370	9" 370 GEAR SET
DPI F890529AX	9" 529 LW GEAR SET
DPI F890486	9" 486 GEAR SET
DPI F890300	9" 300 GEAR SET
DPI F890683AX	9" 683 LW GEAR SET
DPI F890700AX	9" 700 LW GEAR SET
DPI F890733AX	9" 733 LW GEAR SET
DPI F890500	9" 500 GEAR SET
DPI F890389	9" 389 GEAR SET
DPI F890457	9" 456 GEAR SET
DPI F890411	9" 411 GEAR SET
DPI F890471	9" 471 GEAR SET
DPI F890514	9" 514 GEAR SET
DPI F890583	9" 583 GEAR SET
DPI F890600	9" 600 GEAR SET
DPI F890650	9" 650 GEAR SET
DPI F890620	9" 620 GEAR SET
DPI F890633	9" 633 GEAR SET
DPI FS9-28LW	9" 28 SPLINE LW GEAR SET
DPI FS9-31LW	FULL SPOOL 9" 31 SP LW GEAR SET
DPI MS9-28	MINI SPOOL 9" 28 SP GEAR SET
DPI MS9-31	MINI SPOOL 9" 31 SP GEAR SET



Part # 60314 Crush Collar



Part # DPI7044NA 9" Pinion Seal



Part # 60316 9" Gasket



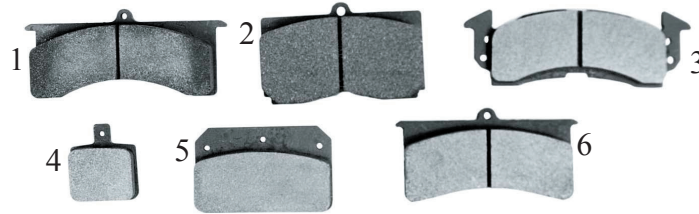

High friction pads typically fade at lower temperatures and are fast wearing. DPI's brake pads have been designed to violate those rules! Extremely high friction, they tolerate low to moderately high temperatures without glazing or fading. In addition, they'll wear substantially longer than hard pads.

REF#	CALIPER	SOFT	HARD	EXTRA HARD	HIGH TORQUE	SUPER TORQUE	EXTREME TORQUE
1	GN Series	005-0974	005-0994	005-0485	005-0495	GN-005-0496	GN-005-0497
3	GM Series (D52)	005-0863	05-1138	005-0681			
4	MGN Single	005-0306		005-0200			
5	MG Dual	005-0300	005-1064	005-0088			
6	71 & XL Series	005-0455	005-0993	005-0118	005-0128	XL 005-0129	XL 005-0139
7	XL Lite	005-5455	005-0993	005-5118			

HARDNESS DESIGNATION	FRICITION CHARACTERISTICS	TEMPERATURE USE
Soft	Very High (Long Wearing)	Low to High
Hard	Medium	Moderate to High
Extra Hard	High	High
Alum. Rotor	Medium (Long Wearing Rotor Friendly)	Moderate to High
High Torque		Moderate to Extreme



Part# DPI 7430

Billet Aluminum Pinto to GM Metric Caliper Bracket

This bracket is stronger and helps eliminate flex experienced with steel brackets. Direct replacement for steel brackets, rolled threads for strength.



PART #	DESCRIPTION
DPI 1740R	Right Hand Bracket
DPI 1740L	Left Hand Bracket

Billet Aluminum to GM Metric Brake Pad Spacer

Use with .810 rotors with GM Metric Calipers. Especially useful with different sized pistons where puck style spacer will not work. 0.250" thick.



Part # DPI 71Insulator

Caliper Piston Heat Insulators

Help reduces brake fluid temperature prolonging piston O-ring life. Available for the new 71 Series caliper and XL & GN calipers.



HARD BRAKE LINE



Coil, 19'8" (-3)
Part # 010-0677

BRAKE DUCT HOSE



3 in. X 10'
Part # 70885

PROPORTIONING VALVES



Part # 012-1729



Part # 012-1730

The "Half Pint" proportioning valve is the smallest, most compact valve available to date, but gives a big 60% pressure reduction over a full pressure range.

- Compact design
- Beautiful red anodized finish
- Universal mounting

ALUMINUM SPINDLE HOSE DUCTS



Part #06001
3" Single Duct Set

Part # 06003
3" Dual Duct Set

Mounts easily on spindle to direct air to center of rotor. A must to reduce brake fading.

RESIDUAL PRESSURE VALVE



PART #	DESCRIPTION
012-1092	Residual Pressure Valve 2 PSI Male/Female 1/8" NPT
012-1093	Residual Pressure Valve 12 PSI Male/Female 1/8" NPT
012-1636	Residual Pressure Valve 2 PSI Female/Female 1/8" NPT
012-1637	Residual Pressure Valve 12 PSI Female/Female 1/8" NPT

PLUMBING ACCESSORIES



Part # 010-0402



TEE -3 INV FLARE FEMALE
Part # 010-1599



STRAIGHT CALIPER STEEL FITTING
1/8" NPT TO -4 MALE
Part # 010-0403



Part # 010-1598

-3 MALE TO 1/8" NPT FEMALE



TEE 1/8" NPT TO -4 INV FLARE FEMALE

In Line Shut Off Valve

Part # 010-0673

The in-line shut-off valve is a must for your system when using an in-dash pressure gauge. It features female 1/8"NPT threads and is rated at 2000 psi.





Part # 290-0633

**WILWOOD Hi-Temp
570 RACING BRAKE FLUID:**

Wilwood's specially formulated Hi-Temp^o 570 Racing Brake Fluid has a minimum 570^o F dry boiling point to withstand the severe heat requirements of automotive racing. Hi-Temp^o 570's low viscosity allows easy bleeding of your brake system, eliminating aeration of the brake fluid caused by foaming due to excessive pumping of the pedal.

BRAIDED FLEX HOSE



PART #	DESCRIPTION
40262-12	12" w/ Straight Ends -4
40262-15	15" w/ Straight Ends -4
40262-18	18" w/ Straight Ends -4
40262-21	21" w/ Straight Ends -4
40262-24	24" w/ Straight Ends -4
40262-30	30" w/ Straight Ends -4
40262-36	36" w/ Straight Ends -4
40262-42	42" w/ Straight Ends -4
40262-48	48" w/ Straight Ends -4
40262-60	60" w/ Straight Ends -4
40263-18	18" w/one 90 -4
40263-24	24" w/one 90 -4
40264-18	18" w/ one 90 -3
40265-18	18" w/ Straight Ends -3
40265-24	24" w/ Straight Ends -3
40265-18-90	18" Straight Ends to 90 -3
40265-24-90	24" Straight to 90 -3



Part # 290-8478

**EXP 600 PLUS SUPER HIGH-TEMP
RACING BRAKE FLUID:**

EXP 600 Plus is a highly refined blend developed for extreme performance under the high heat and extreme pressure of professional motorsports. What's in a number? EXP 600 Plus has tested to 626 degrees F with a wet boiling point of 417 F. These numbers far exceed any DOT or SAE specifications.

ROTOR BOLT & CALIPER SHIM KITS

PART #	DESCRIPTION
011-0399	1/4" - 20 Flat Socket Head Bolt (8)
01-0089	1/4" - 20 Socket Head Bolts Drilled (8)
011-0064	1/4" - 20 Socket Head Bolts Drilled w/ Washers
011-0063	5/16" - 18 Hex Head Bolts w/Washers For Wide Five (8)
011-0453	5/16" - 18 7/8" Drilled w/Washers (6)
011-0686	5/16" - 18 5/8" Button Head Bolts w/Washers (6)
011-0571	5/16" - 18 3/4" Button Head w/Washers (8)
011-0256	5/16" - 24 Flat Socket Head Bolts w/Nuts (8 Bolt In Board)
011-0338	5/16" - 24 Flat Socket Head Bolts w/Nuts (6 Bolt In Board)
011-0062	5/16" - 24 Socket Head Bolts Drilled w/Washers (6)
011-0575	Shim Kit - MGN (12)
011-0671	Shim Kit - XL/GN (12), Series 71
011-0769	Bolt Kit - Caliper Mount (Pinto MGN) (2 Calipers)
011-0614	Bolt Kit - Caliper Mount, MGN Series (2 Calipers)

Tech Note: Use shim kits to get a true alignment on your caliper



Part # 15-601600

AP 600 FLUID

has been developed for racing applications where higher than normal temperatures are being experienced, e.g. when using carbon/carbon discs and the ultimate in brake fluid performance is required.



STEEL ENGINE HUB



Part # DPI QM125

AIR CLEANER ADAPTER

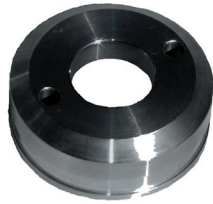

Newly designed air cleaner adapter.
Part # DPI QM200

ALUM. QUICK RELEASE STEERING HUB

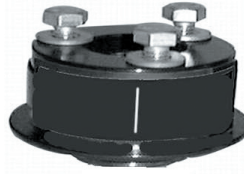

NASCAR Style Steering Wheel Hub
Part # DPI QM100

QUARTER MIDGET SPLINE



Part # DPI QM100-SPLINE

LAMINATED NUMBER SET



Laminated Number Set 3 of each number 0-9 includes the letter X.
Part # DPI QM150

ENGINE HUB GEAR PULLER



Engine hub gear puller for quarter midgets
Part # DPI QM140

LEXAN NUMBER HOLDER



Tired of the hassle of taping numbers on? Protect and display your laminated no. set, Includes Hardware.
Part # DPI QM175

FUEL CATCH CAN

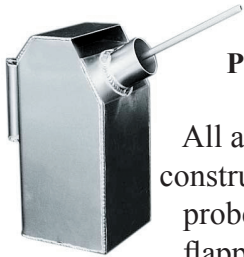

Part # 09002

All aluminum construction with probe to open flapper valve.

DS/DR BREATHER TANK



Part # 02001

Breather tank combo, includes baffle and roll bar mount. Complete with petcock and element.

QUICK CHANGE DRAIN PAN

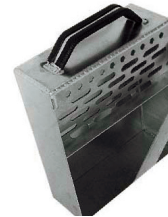

Part # 09300

All aluminum drain pan with drip tray. Vinyl trim on handle.

EXPANSION TANK



Part # 03001

Roll Bar type mount included.

POWER STEERING RESERVOIR TANK



Part # 01501

Includes non-vented cap and economy mount that fits any diameter bar.

FUEL CELL VENT TUBE W/FLAPPER VALVE



Part # 05001
1" Valve

Part # 05003 1 1/4" Valve
(Spring Loaded)



1. Remove the existing brake line from the master cylinder. Determine if your master cylinder has 1/8" pipe thread or -3 AN threads. NOTE: The DPI Sure Stop is designed to use with 1/8" pipe thread on all four ports. The -3 AN fitting that is supplied with the kit is for use with Tilton type master cylinders. Using one of the fittings supplied, install your DPI Sure Stop recirculator directly onto the master cylinder. If clearance is a problem for mounting, you can remote mount your recirculator. Keep within 12 inches of master cylinder. Top plugged hole can be used to hook up brake gauges.
2. Connect the existing brake line from the calipers to the outlet side (to calipers) of the recirculator.
3. Remove the existing bleeder assembly for the calipers and install the new cross over tubes. You will need to install a new set of hard brake lines to the calipers. These will serve as the return lines for the brake fluid (see illustration) install a new flex line from the crossover tube to the hard line returning to the recirculator (return from bleeder).
4. NOTE: DPI has cross-over tubes available for most calipers or we can custom make them to your specifications; See page 11.
5. Now you are ready to go! Just pump the brake pedal up and down several times. Your system should self-bleed. If the pedal is not firm, repeat until all the air is out of the system. See note below.
6. The bleed screw on the recirculator can be used to bleed the system, but the main purpose is for the use of a brake bias gauge for setup.

Thank you for purchasing our products and good luck racing! We hope the DPI Sure Stop along with all of our competition proven products will help you get to the winner's circle.

Tech Note: If the system is dry, you may have to open the return line at the caliper crossover tube to help get the air out of the system. Do the same thing at the return port on the recirculator. In a hard to bleed system it may be necessary to pressure bleed. Always start from the farthest point first.

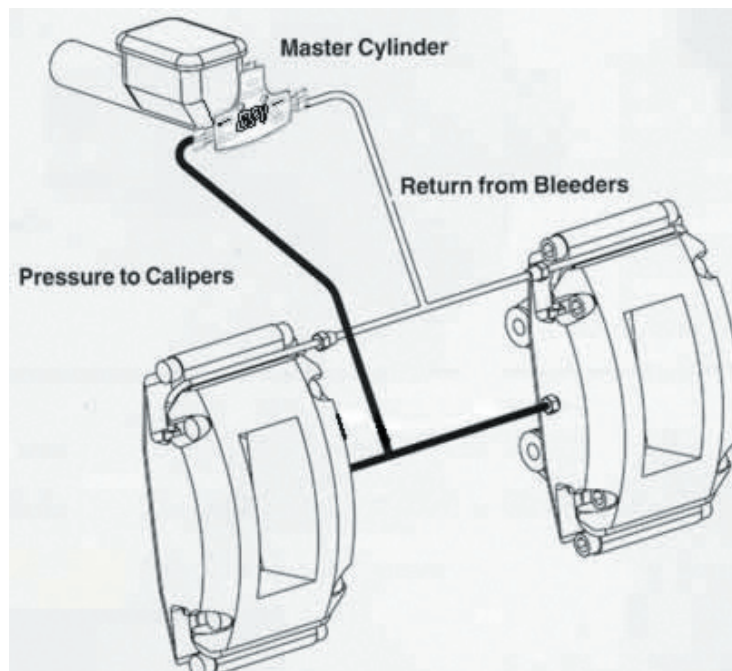

1. Remove the existing brake line from the master cylinder. Determine if your master cylinder has 1/8" pipe thread or -3 AN threads. NOTE: The DPI Sure Stop II, Part A and Part B, are designed to use 1/8" pipe thread on all ports. The -3 AN fitting that is supplied with the kit is for use with Tilton type master cylinders. Using one of the fittings supplied, Install Part B on the rear master cylinder, then install Part A onto the front master cylinder. If clearance is a problem for mounting, you can remote mount your recirculator, however it has to be installed within 12" of the master cylinder and at the same height or lower.
2. Bridge the front and rear master cylinder reservoirs together using the plastic tube and fitting furnished, or use part# 2185 (recommended dual reservoir). This allows the fluid to be transferred back to the rear master cylinder after it is returned through the system. Caution: if you are using plastic reservoirs, drill holes 11/32" diameter. DO NOT run the 1/8" pipe tap too deep. If the master cylinders are mounted close together it will be easier to loop the tube in front of the reservoir.
3. Connect Part B to the port marked (from rear master cylinder) onto Part A with the short steel tube provided. Connect Part B port marked (to rear calipers) to the rear calipers.
4. From Part A connect one line from the port marked (to caliper) to each front caliper, this is the pressure side (diagram 1). Optional installation for maximum cooling and recirculating benefits use part #2115, (diagram 2) to pressure feed the outer caliper halves. This is where the most heat is generated.
5. Connect one line from each caliper bleeder (recommended use part #2108 cross over tube) back to Part A port marked (from bleeders). This is the return side.
6. Fill the system with brake fluid. Pump the brake pedal. When the fluid begins to move, the system will start to bleed itself.
7. If you purchased the optional kill switch with your Sure Stop II Brake Recirculator, screw the switch into the top port on Part A. Wire from the ignition switch to the positive side of coil. DO NOT run other accessories or alternator on this switch. When the brake pressure rises approximately 200 psi above normal operating pressure, the ignition will shut off, when the pressure is reduced, the ignition will be reconnected. If it becomes necessary to change the switch setting, loosen the nut and rotate the top (out for higher, in for lower). Move in small increments of 1/8" at a time.

Part #: DPI 2160

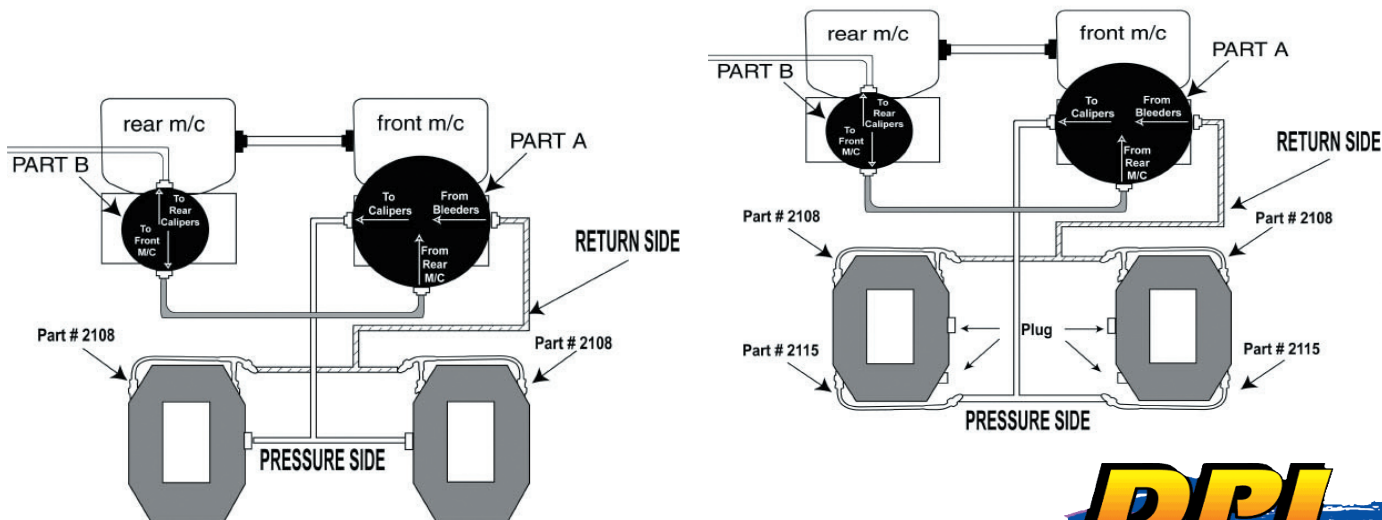

Recommended Use Of Gear Oil For The Platinum Track Differential (ONLY):

- Joe Gibbs Performance Gear Oil - 75/110
- Redline Gear Oil - 75/90
- Redline Gear Oil – 75/140
- Royal Purple Gear Oil – 75/140
- Kendall Gear Oil

Note: We do not recommend using Redline Shock Proof Oil or Mobil Gear Oil for the Platinum Track

- Please change oil after 250 laps
- Use DPI 1300 Fortifier: 1 bottle per 4 quarts of oil
- Use 4 quarts of oil for 9” and Q/C with a ½ in. vent
- This unit is not serviceable by the end user. DPI will service all units. Most of the time DPI has a 24 to 48 hour turn around.
- Recommended use of oil cooler with all differentials.

Items to check:

- **Axle engagement - axles need to be engaged a minimum of one inch. If run with less than one inch you could damage the unit.** The easiest way to check is to put white grease on the end of the axle spline. Put axle in housing and push in until flush with the drive plate. Then push in an additional 3/16”. Now pull axle out. Measure the amount of spline engagement into the differential by how far the grease has moved up the spline. Minimum 1”.
- With the platinum track you cannot use a lockup plug.
- 8.8 platinum must use c-clip eliminators.

All service is done through DPI only. Any questions, call our service department at 707.283.4374



**INSTALLATION INSTRUCTIONS
FOR THE BLACK GOLD OR PLATINUM TRACK DIFFERENTIALS**

- STEP 1. Stand rear-end vertical on right wheel. Remove rear cover, remove quick change gears, using end of pinion, check and record lash.
- STEP 2. Remove left bell, remove ring gear rubbing block and back adjusting stud out at least 2 turns. Remove spool and ring gear assembly and center section from right bell.
- STEP 3. Remove “O” rings from both bells. Clean both bell flanges and each side of center section. Install complete shim package under right set up bearing. With the Platinum Track differential sitting in the right bell, tap with a dead blow or rubber hammer until the shim package is formed to the radius of the bearing inner shoulder, without the ring gear.
- STEP 4. Install the center section. Install the unit with shims and right set up bearing. Install the left bell with no bolts.
- STEP 5. Using three .007 feeler gauges in a triangular pattern between left bell flange and center section, remove shims from right set up bearing until you have .007 clearance. Set aside the shims you have removed, they will not be used. Install ring gear to unit. Remove a .010 shim from under the right setup bearing.
- STEP 6. Install unit back into the right bell with shims. Install the .010 shim that you removed from the right setup bearing, under the left setup bearing. Install the left bell, remember only the shim that gave the .007 clearance. Install all through bolts and torque to 35 ft lbs. Check the lash, if it is not correct, move the suitable shim from under right set up bearing and install under the left setup bearing. Re-torque after each shim change until you get the recorded lash.
- STEP 7. Turn the ring gear 360 deg. To check for run out. When you have the proper lash and the bolts torqued you should have .007 preload on the bells.
- STEP 8. Remove the Platinum Track Differential, keeping the shims in the proper side; install the carrier bearings in place of the setup bearings. Install the “O” rings in the bells with a slight amount of silicone.
- STEP 9. Reassemble – don’t forget the ring gear rubbing block, lube with grease on rubbing surface and stud to hold in place. All torqued, retighten rubbing block and stud until rubbing block contacts ring gear. Back off 90 deg. and tighten the jam nut.

Platinum Track Settings		Black Gold Settings	
1/4 Tight Unit	40-60 FT LBS	1/2 Tight Unit	90-110 FT LBS
1/2 Tight Unit (Standard)	80-100 FT LBS	3/4 Tight Unit	110-120 FT LBS
N/A	N/A	Full Tight	120-135 FT LBS



How does it work? Simple, if either tire starts to slip the unit's automatic traction management system transfers torque to the tire with the traction until the tire slippage stops, making the car corner faster and smoother and requiring less stagger than a spool or locker, reducing drag while eliminating the loose side effects of open style differentials.

Before running the Platinum Track or Black Gold Differential, please read the following information:

1. This unit is like any other high performance component. Use a good quality synthetic oil and always use a minimum of 4 quarts; this will extend the life and performance of these units. we recommend adding a 6 oz. bottle of DPI Liquid Gold Fortifie: Part# DPI 1300.
2. When installing the unit it is important to check for proper axle engagement. Take white grease and apply it at the end of your axle. Push the axle into the rear-end housing until it is flush with the end of the drive plate. Remove the axle and measure the amount of grease removed by the splines in the gear; it should measure a minimum of one inch of axle engagement.
3. On all Black Gold Differentials (Gold Tracks Differentials), if you are using floater axles, you must use a bolt to keep the axles from moving side to side. Make sure that the bolt and lock nut are clean and be sure to use loctite I.D. mark. On bolt head must be ground off and domed slightly. On the Platinum Track Differential there is a divider plate in the center; no bolts required.
4. Do not use any type of additives, such as slick 50, or any with Teflon or Molly's. This will damage the unit.
5. We suggest you build a set of checker tools to periodically verify the preload of your unit see Fig. 1 & 2, on the following page you can make these from a set of old axles. Use a standard type clicker torque wrench at the end of Tool #2. The range of brake away torque should be as follows:

Platinum Track Settings		Black Gold Settings	
1/4 Tight Unit	40-60 FT LBS	1/2 Tight Unit	90-110 FT LBS
1/2 Tight Unit (Standard)	80-100 FT LBS	3/4 Tight Unit	110-120 FT LBS
N/A	N/A	Full Tight	120-135 FT LBS

6. To extend the life of your unit, you should change the oil approximately every 250 laps.
7. If you are running a preloaded unit and begin to experience a loose condition under entry, make sure to check the breakaway torque, this is an indication that the differential might be in need of service.
8. If you make tool #2 long enough you can check your unit in the car with one tire on the ground and out of gear.
9. This tool can also be made from an old wheel. Measure 18" from the center, weld 1/2" drive socket.
10. Have your differential serviced at least once a year; it will save you money and time in the long run.



CHECKING TOOLS FOR MEASURING PRELOAD

TOOL #1 (CLAMP TOOL TO BENCH)

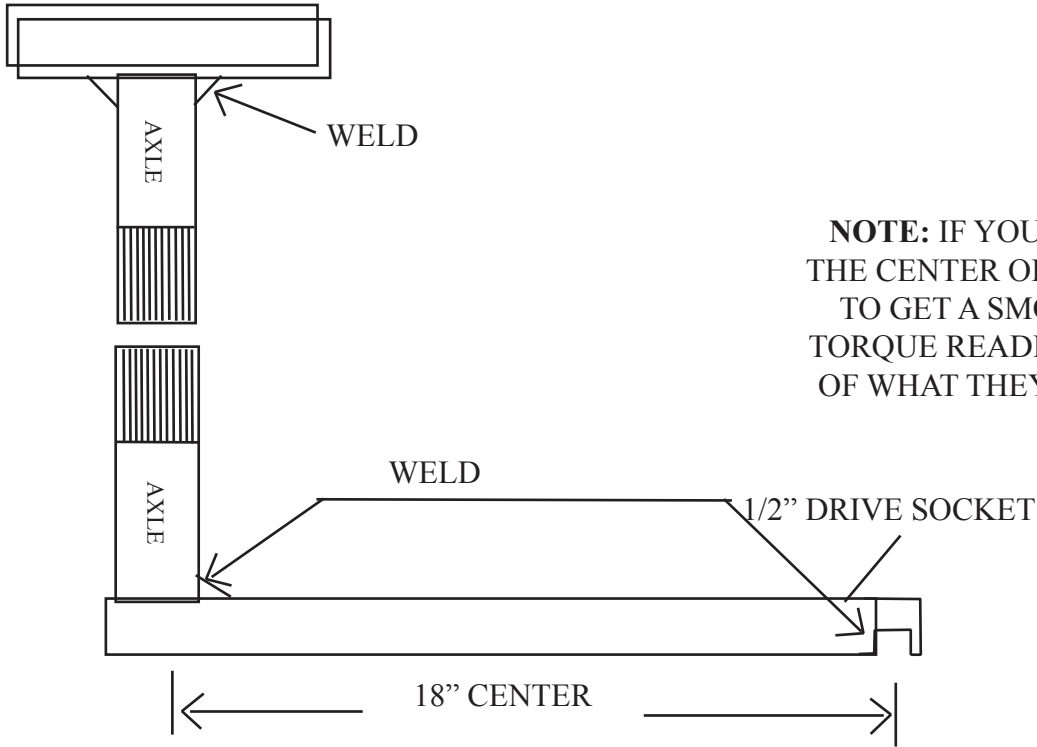

NOTE: IF YOU CHECK PRELOAD AT THE CENTER OF THE AXLE IT IS HARD TO GET A SMOOTH READING AND TORQUE READINGS WILL BE DOUBLE OF WHAT THEY ARE AT THE 18" END.

TOOL #2 (CHECKING PRELOAD WITH UNIT INSIDE CAR)

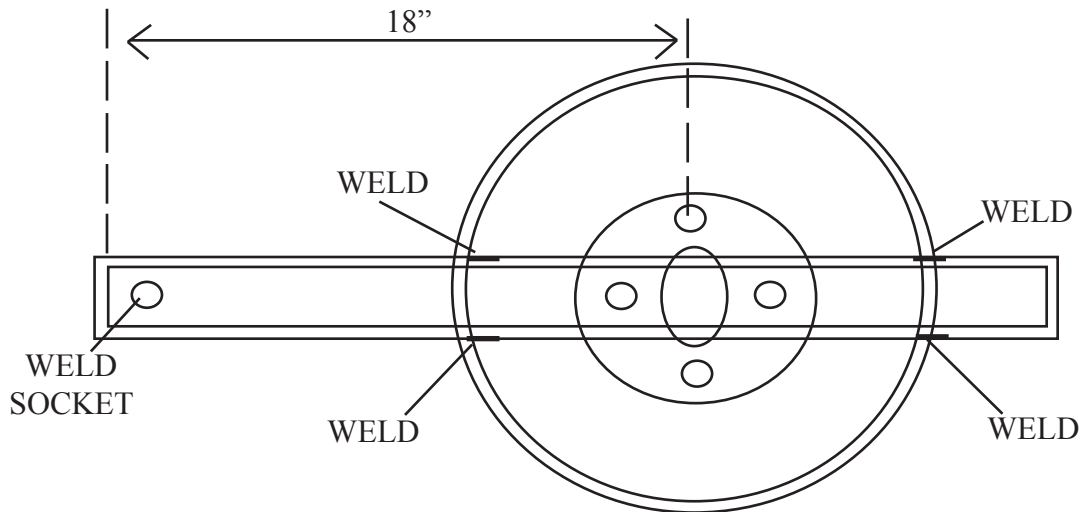

*USE OLD WHEEL