



Free Flow Exhaust Installation Instructions

PART NUMBER D660-0002

APPLICATION: 2004 - 05 645ci

Thank you for purchasing a Dinan High Performance Muffler! Some mechanical skill is required to install this muffler. If you are not familiar with this procedure, we strongly recommend that you arrange for a qualified BMW repair facility to perform this installation.

INSTALLATION:

- I. Hold the new Dinan muffler up under the stock muffler. Line up the exhaust tip on the new muffler with the exhaust tip on the stock muffler. The new Dinan Muffler Pipes are a slip fit over the stock pipes. You will need to have enough overlap to seal well (2.0" – 2.5"). The stock pipes will need to be cut at a point 2.0" to 2.5" longer than where the new Dinan muffler pipes end. Mark the Pipes at this point and check the mark position with the measurements in the next step.

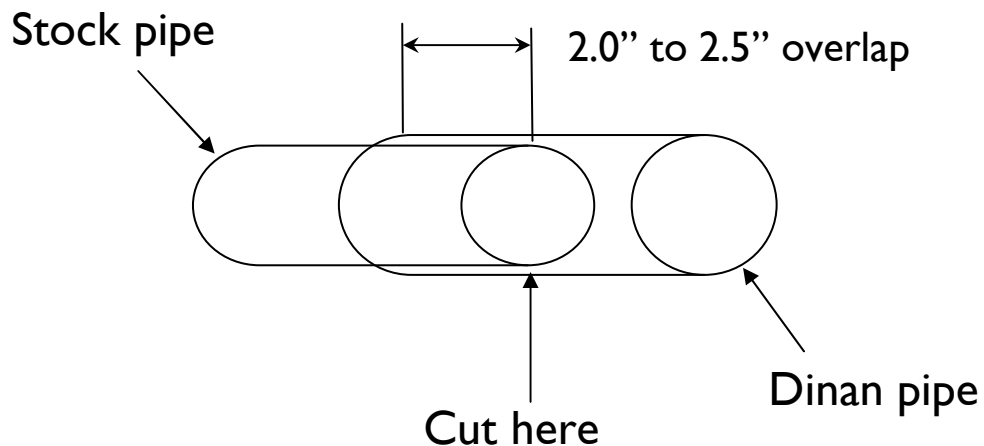

2. Check to see if your marks are about 4.5" from the cross support on the pipe bracket closest to the differential. See figures 2 & 3.

The cut mark should be close to the start of the radius of the bend in the pipe going into the muffler. See figures 4 & 5.

When you are confident you will have enough overlap, cut the pipes. (Be careful not to cut into any surrounding parts.)

3. Deburr the inside of the stock exhaust on the car and clean the outside surface to ensure a good seal.

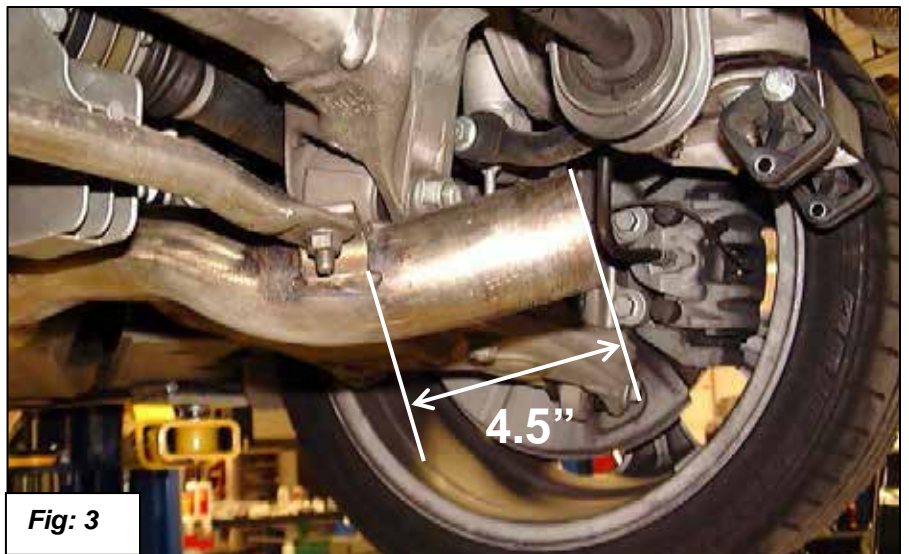
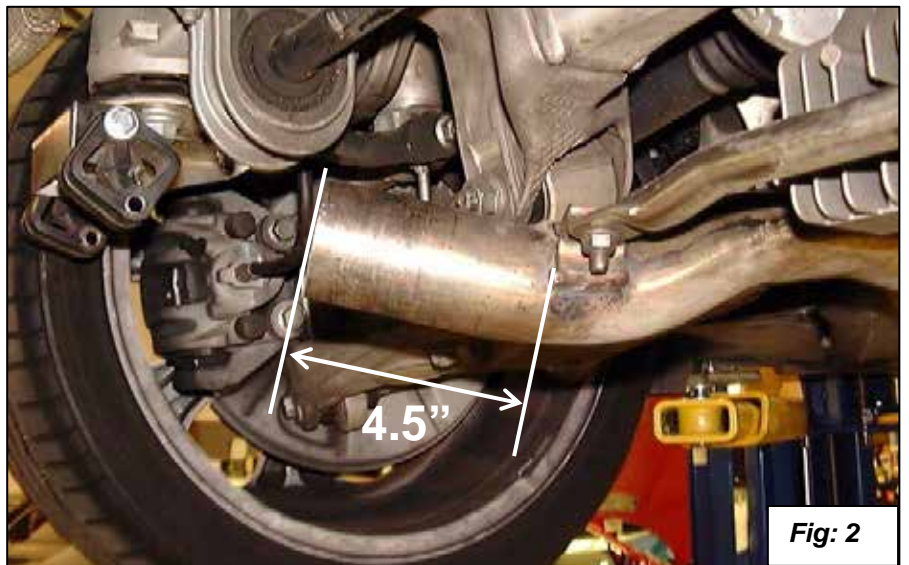

- Remove the stock mufflers by unbolting the rubber hangers from the car. Each of the two hangers is held in place with two 13mm nuts. See figures 5 and 6.

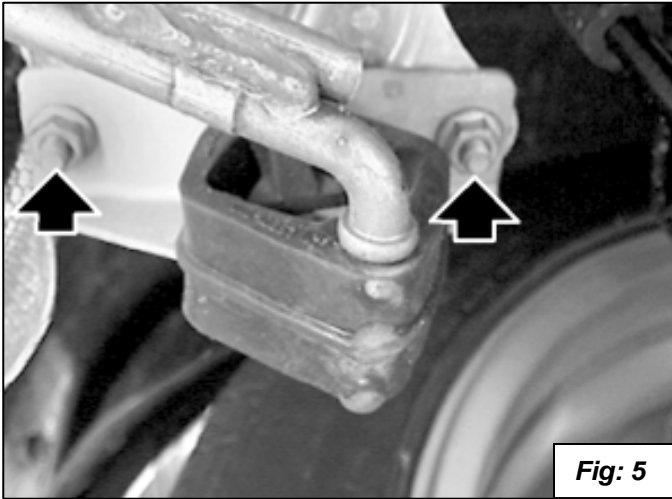

Fig: 5

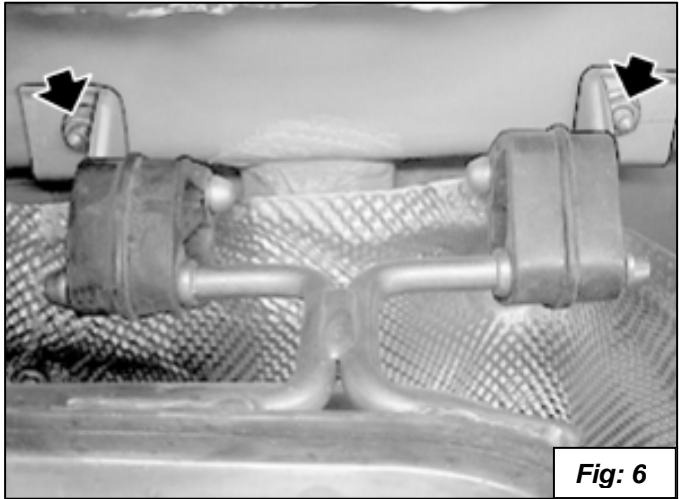

Fig: 6

- Remove the rubber hangers from the stock mufflers by pulling them off the wire hangers.
- Install the metal spacers into the rubber hangers as shown in figure 7.
- Install the rubber hangers with spacers onto the new hangers. The front hangers go on the outside of the new front mounts. See figures 8,10 and 11. The rear hangers go on the opposite side of the bolt flange as shown in figure 9. Make sure you put a washer on both sides of each rubber mount. Install the ground strap on the outer hanger on the front mount. See figures 10 and 11.

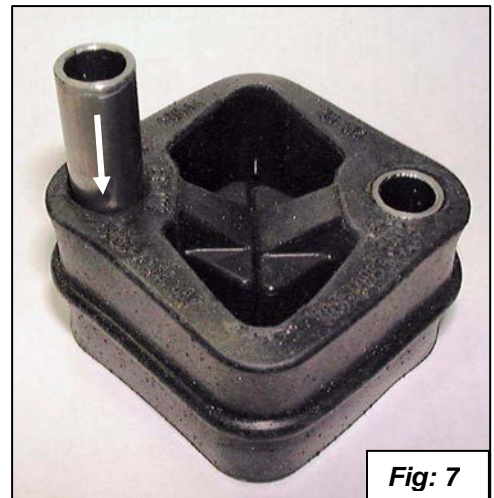

Fig: 7

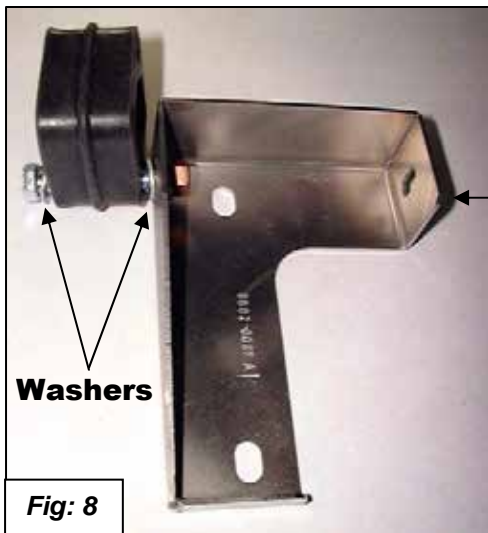

Fig: 8

Drivers side shown.
 Front Bracket with one hanger attached.
 Rear Bracket.

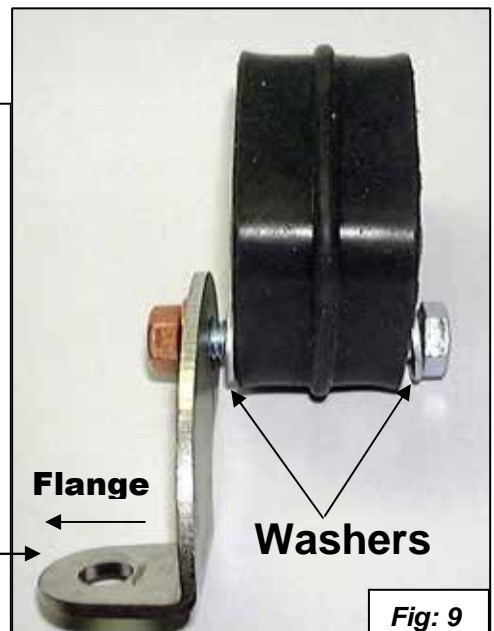
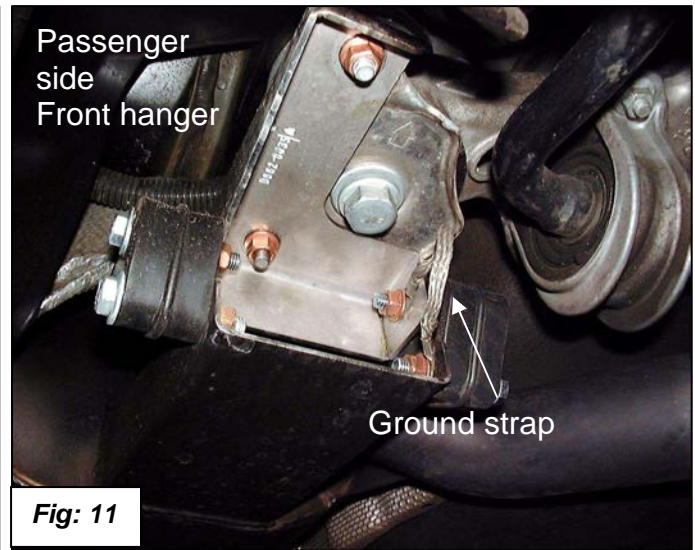
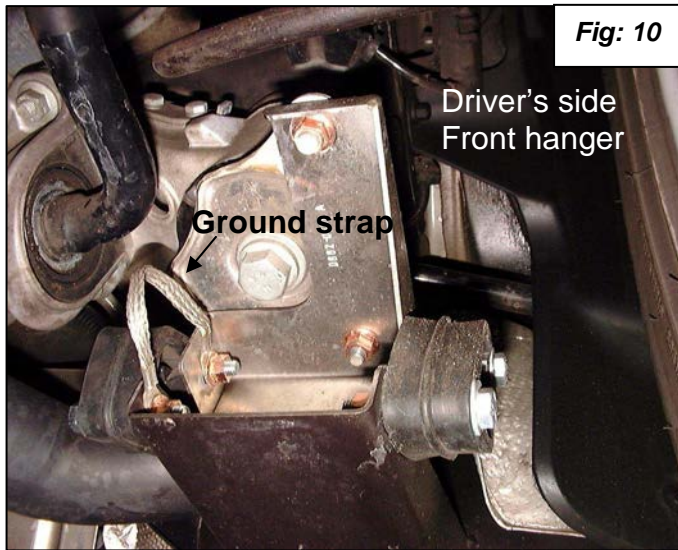

Fig: 9

8. Install the front hangers onto the car as shown in figures 10 and 11. Torque the nuts and bolts to 30nm or 22ft-lbs.



9. Install the rear hangers onto the car by removing the lower inner bumper bolt and placing the hanger between the bolt and car as shown in figures 12 and 13. Torque the bumper bolts to 36nm or 26.5ft-lbs and the mount nuts and bolts to 30nm or 22 ft-lbs.



10. Slide the Dinan muffler over the stock tubes as you place it in position. It may be necessary to rotate the muffler and unhook the exhaust mounts at the differential. (On a convertible you will need to loosen and drop down the support braces.). See figures 14 and 15.

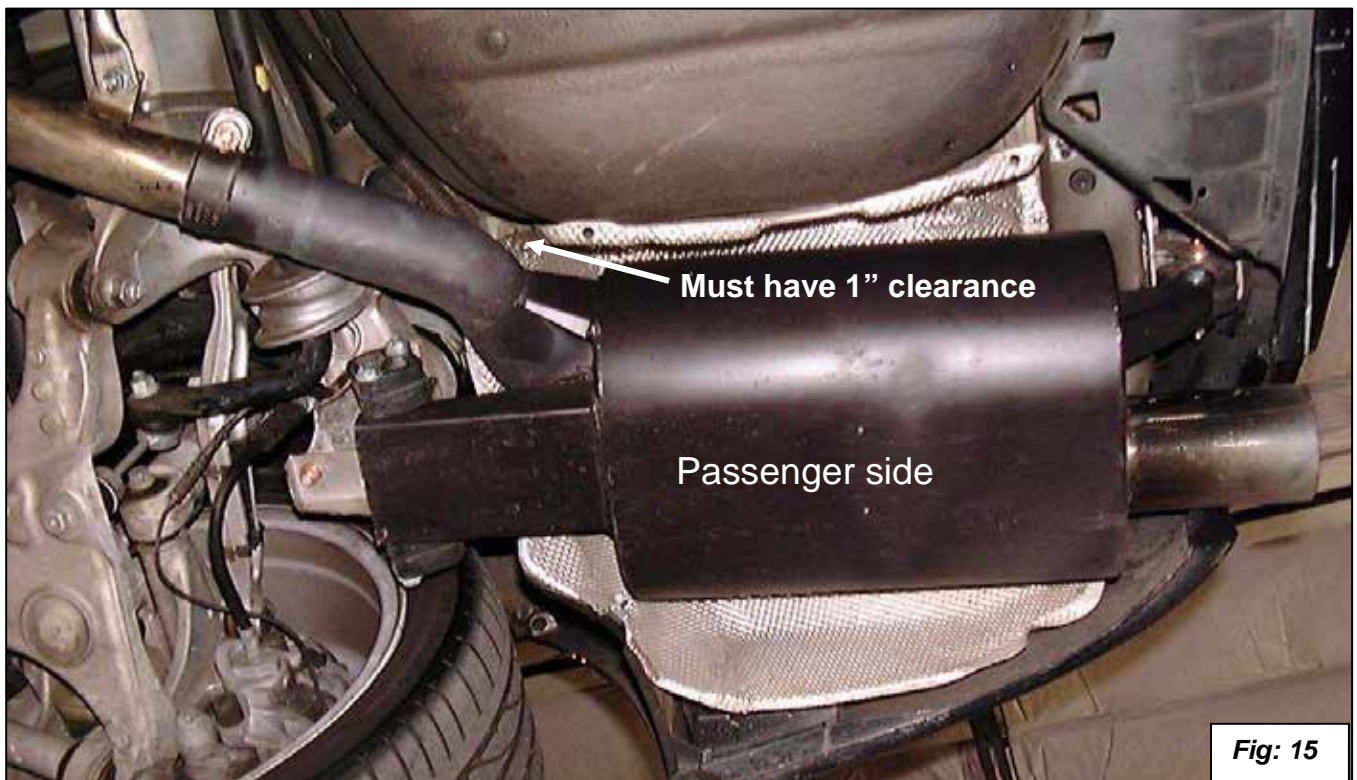
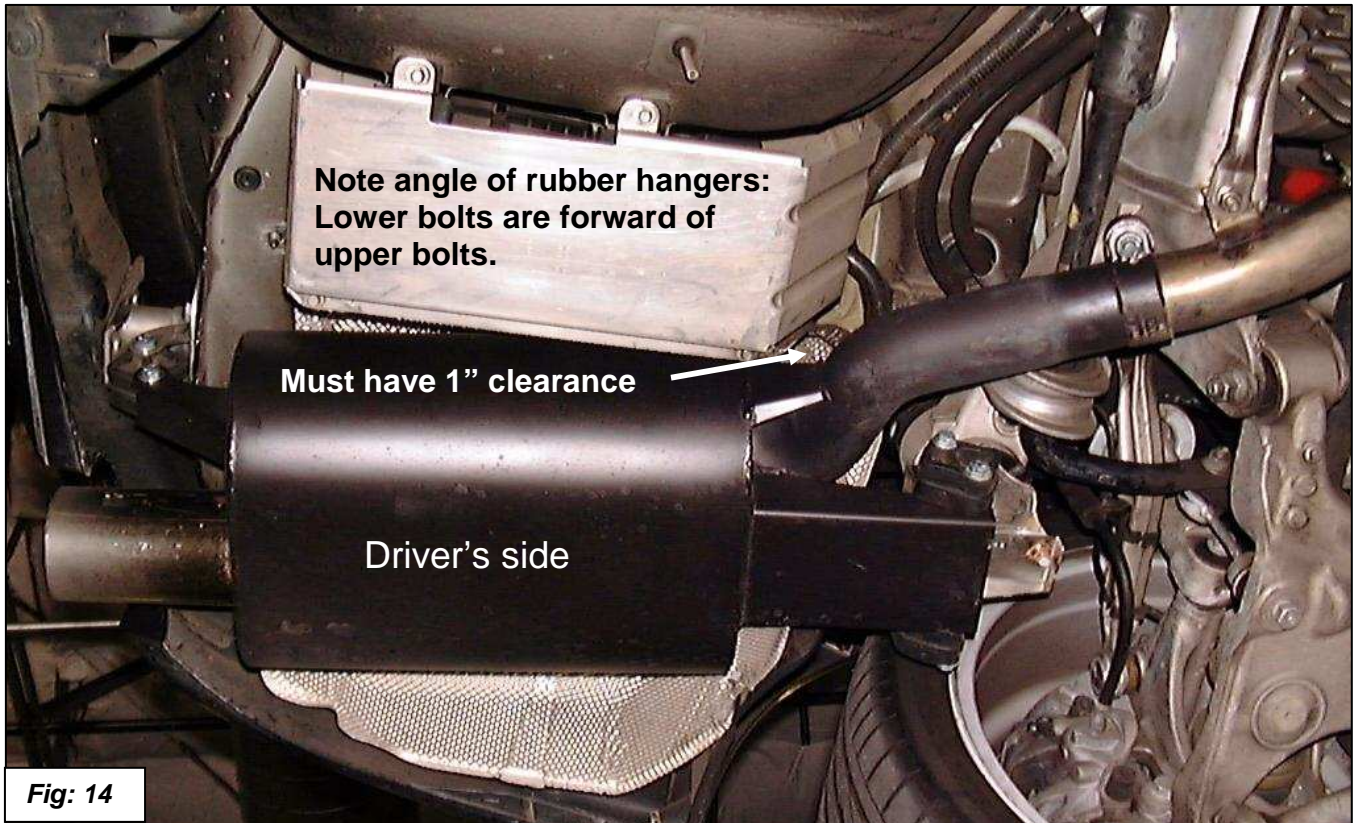

11. Install the muffler by attaching the muffler to the hangers. Adjust the muffler for best fit centering the exhaust tip in the bumper cut out. The hangers should be angled forward as shown in figures 14 and 15. When the exhaust gets hot it grows in length and the hangers will go straight. Don't forget to hook up the ground strap to the hanger bolt.



Fig: 16



Fig: 17

12. Visually inspect the muffler. Check for at least $\frac{1}{2}$ " clearance in all areas and 1" in the rearward direction to allow for the exhaust system to grow in length. See figures 14 and 15. You can bend the heat shields slightly to help you get this clearance. Make sure the polished tips are centered in the bumper cutouts. See figures 16 and 17. Tighten the clamps to 22 ft.-lbs, as you make sure the tips stay centered.

Some customers prefer the muffler to be black while most prefer the unpainted stainless look. If the customer would like there mufflers black, it is ok to paint them black with high heat muffler paint before installation. Tape off the polished tips and wash the mufflers with acetone, and follow the paint manufacturer's instructions.

Happy Motoring!