



DEMCO

2020 TRAILER COMPONENTS



Available Finishes.....	4
Actuator Configurations	5

ACTUATORS

DA66B 6000 lb. G.V.W.R.....	7
DA86 8600 lb. G.V.W.R	7
DA91 7000 lb. G.V.W.R. For Drum Brakes	8
DA75 7500 lb. G.V.W.R. For Drum Brakes	8
DA75 7500 lb. G.V.W.R. For Disc Brakes	8
DA91 8000 lb. G.V.W.R. For Disc Brakes	8
DA91 8000 lb. G.V.W.R. For Drum Brakes	9
DA91 8000 lb. G.V.W.R For Drum Brakes	10
DA10 12,500 lb. G.V.W.R. For Disc Brakes	11
DA10 12,500 lb. G.V.W.R. For Drum Brakes	11
DA10 12,500 lb. G.V.W.R. For Drum Brakes	12
DA16 16,000 lb. G.V.W.R. For Disc Brakes	13
DA20 20,000 lb. G.V.W.R. For Disc Brakes	13
DA20 20,000 lb. G.V.W.R. For Drum Brakes	14
Actuator Kits DA91 • DA10 • DA20.....	15
Actuator Replacement Components.....	15

COUPLERS

2" Ball Coupler 6000/7000/10,000 lb. G.V.W.R.....	20
2" Ball Coupler 10,000 lb. G.V.W.R.....	20
2 5/16" Ball Coupler 21,000 lb. G.V.W.R	22
2 5/16" Ball Coupler 12,500/18,000/20,000 lb. G.V.W.R	23
Combos, Couplers and Channels	24
Pintle Ring 25,000 lb. G.V.W.R.....	24
Channels 7,500-21,000 lb. G.V.W.R.	24
Clevis Coupler 10,000-20,000 lb. G.V.W.R.....	25

TONGUES

Tongues	25
---------------	----

HYDRAULIC BRAKE ASSEMBLIES

10" Hydraulic Brake Assemblies	26
12" Hydraulic Brake Assemblies	27
13" Hydraulic Brake Assemblies	28

BRAKE LINES

Brake Line Kits.....	29
Brake Line Components.....	30
Spare Tire Mounts	31
Parts Explosions.....	32-37

Over the years we've been printing catalogs to help customers like you purchase quality products. Every item in this catalog reflects our commitment to quality, durability, efficiency and value.

Our new Trailer Components Catalog is specifically designed to help you configure items and to avoid much of the confusion related to choosing features available on specific products. If you have any questions on availability or compatibility to your application, call us at

"Doing our best to provide you the best".

DEMCO



THE BOYDEN FACILITY IS
CERTIFIED TO ISO 9001:2015

DEMCO

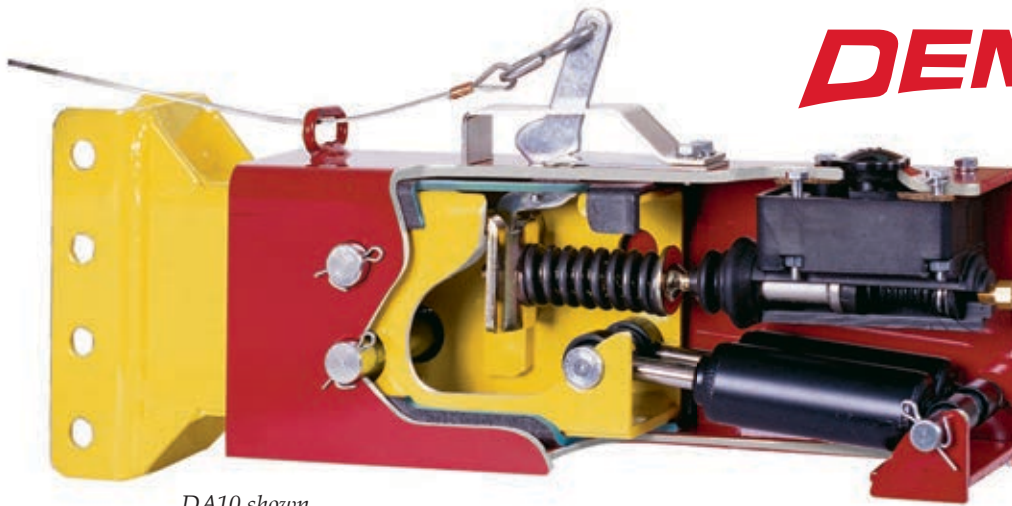

DA10 shown

With industry leading features, Demco Actuators are built heavy duty in the USA for the safest braking and extended trouble-free life.

Available in 6000 lb. to 20,000 lb. G.V.W.R. models.

FEATURES

- Diaphragm in master cylinder cap provides completely enclosed system
- Raised fill plate prevents intrusion of contaminants when removing cap
- Tie loops on cap allow for tethering, creating a tamper-proof seal
- Bellow boot on push rod for more resistance to moisture and contaminants
- Color-coded decal on emergency lever allows quick glance if brakes are on or off
- Actuators fit standard 3" tongues - 4" is available as an option
- 50° A-frame mounts available
- Acetyl Copolymer liners eliminate reliability issues with rollers
- Line pressure controlled by spring loaded push rod
- Integrated shock dampening design
- Emergency cable is attached with a new clevis for easy replacement in the field
- Finishes include Silver Metallic, Black, Zinc and Primed for corrosion-free operation
- Standard master cylinder (U.S. Patent #6,658,844) on all actuator models are made of long glass reinforced nylon. Rust and corrosion are eliminated.
Anti-splash baffle deflects the brake fluid "geyser effect" when bleeding system
New composite master cylinder retrofits previous models without modification
- DA20 disc brake actuators have an optional 1-1/4" bore aluminum master cylinder and heavy-duty push rod assembly for higher line pressures required for 3 or more axles



Slide Kit



U.S. Patent No. 6,658,844

Composite Master Cylinder



U.S. Patent No. 6,658,844

Aluminum Master Cylinder

DEMCO AVAILABLE FINISHES

Demco Actuators and Couplers are available in 4 durable finishes

Silver: -52

Powder coated silver metallic finish



Black: -81

Powder coated black finish

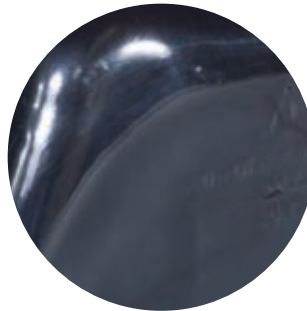

Zinc: -95

Plated zinc finish



Primed: -97

Powder coated primed paint finish



DEMCO ACTUATOR CONFIGURATIONS

COUPLER CHANNEL AND COUPLER POSITIONS

Channel Down



Channel Center



Channel Up



OUTER CASE CONFIGURATIONS

3 Hole Straight



3 Hole Standard



3 Hole



2 Hole



Weld On with Tube Mounts



50° Mount



5 Hole



Weld On - No Mount



With Angle Mounts



DEMCO ACTUATOR MOUNTING PATTERNS

DA66B Mount

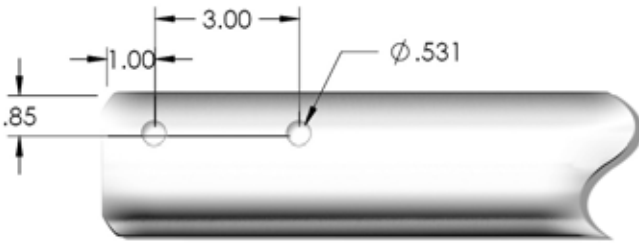

DA86B Mount

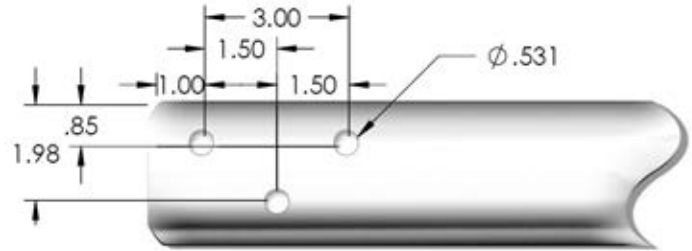

2 Hole Standard

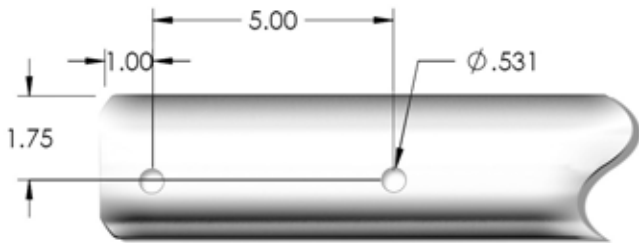

5 Hole Standard

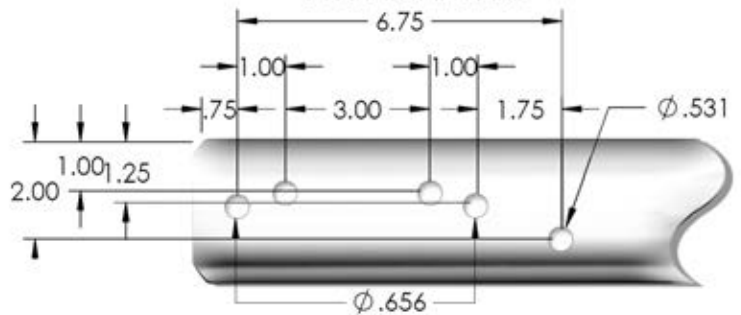

3 Hole

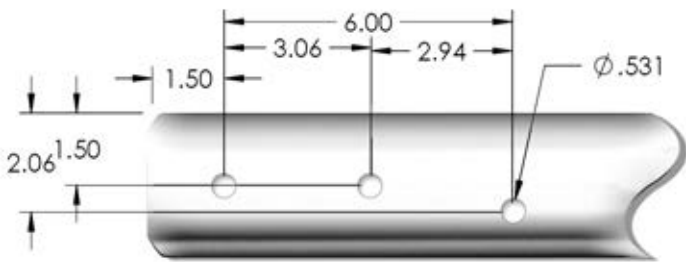

3 Hole Straight

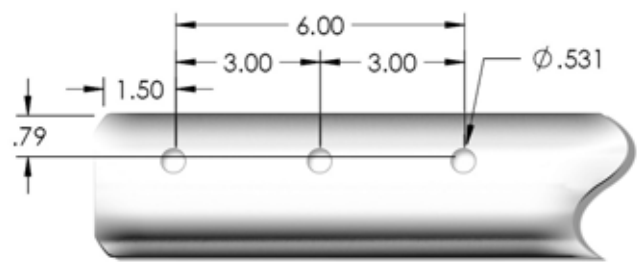

3 Hole Standard

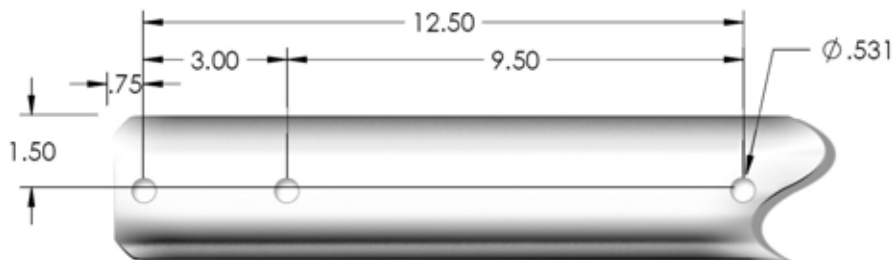

DA66 6000 LB. G.V.W.R.

DRUM BRAKE ACTUATOR for use in marine applications. Zinc plated. 6000 lb. G.V.W.R. maximum rating. 600 lb. tongue load, limited to coupler rating. Mounts on 3" tongue with 2 - 1/2" x 4-1/2" grade 5 bolts. Lever-lock coupler design.

ITEM #	TYPE	DESCRIPTION	WT (LBS.)
8605001	DA66B	Plated, top mount, lever lock coupler	21



8605001

DISC BRAKE ACTUATOR for use in marine applications. Zinc plated. 6000 lb. G.V.W.R. maximum rating. 600 lb. tongue load, limited to coupler rating. Mounts on 3" tongue with 2 - 1/2" x 4-1/2" grade 5 bolts. Lever-lock coupler design. Reverse solenoid and cover included. **Solenoid requires power from back-up lights on tow vehicle**

ITEM #	TYPE	DESCRIPTION	WT (LBS.)
8605101	DA66B	Plated, lever lock coupler <i>Includes factory installed blocking solenoid kit</i>	22



8605101

DA86 8600 LB. G.V.W.R.

DRUM BRAKE ACTUATOR for marine and light utility applications. Zinc plated and black powder coated finishes available. 8600 lb. G.V.W.R. maximum rating. 800 lb. tongue load, limited to the coupler rating. 2" EZ Latch coupler is the safest in the industry for easy hook up and safe operation. Large rollers in rear provide easier and smoother operation of the actuator. Reinforced outer case to prevent over tightening of the 3 - 1/2" x 4" grade 5 bolts. Mounts on 3" tongue.

ITEM #	TYPE	DESCRIPTION	WT (LBS.)
8608601	DA86	Plated, 2" EZ Latch, bolt on case	25



8608601

DISC BRAKE ACTUATOR for marine and light utility applications. Zinc plated and black powder coated finishes available. 8600 lb. G.V.W.R. maximum rating. 800 lb. tongue load, limited to the coupler rating. 2" EZ Latch coupler is the safest in the industry for easy hook up and safe operation. Large rollers in rear provide easier and smoother operation of the actuator. Reinforced outer case to prevent over tightening of the 3 - 1/2" x 4" grade 5 bolts. Mounts on 3" tongue. Reverse solenoid and cover included. ** Solenoid requires power from back-up lights on tow vehicle**

ITEM #	TYPE	DESCRIPTION	WT (LBS.)
8608611	DA86	Plated, 2" EZ Latch, bolt on case, includes blocking solenoid	22



8608611

ACTUATORS

DA91 7000 LB. G.V.W.R. FOR DRUM BRAKES

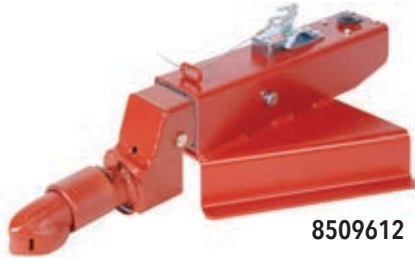

8509612

2" SLIDE-LOK

ITEM #	POSITION	OUTER CASE	COATING	NOTES	WT (LBS.)
8509202	Center	3 Hole Standard	Primed		43
8509602	Center	50° Mount	Primed		62
8509612	Down	50° Mount	Primed		64

DA75 7500 LB. G.V.W.R. FOR DRUM BRAKES



8778002

2" EZ LATCH

ITEM #	POSITION	OUTER CASE	COATING	NOTES	WT (LBS.)
8778001	Center	Inline	Black	No Bypass	33
8778002	Center	Inline	Zinc	No Bypass	33
8778003	Center	Inline	Silver	No Bypass	33

DA75 7500 LB. G.V.W.R. FOR DISC BRAKES

2" EZ LATCH

ITEM #	POSITION	OUTER CASE	COATING	NOTES	WT (LBS.)
8778004	Center	Inline	Black	No Bypass	33
8778005	Center	Inline	Zinc	No Bypass	33
8778006	Center	Inline	Silver	No Bypass	33

DA91 8000 LB. G.V.W.R. FOR DISC BRAKES

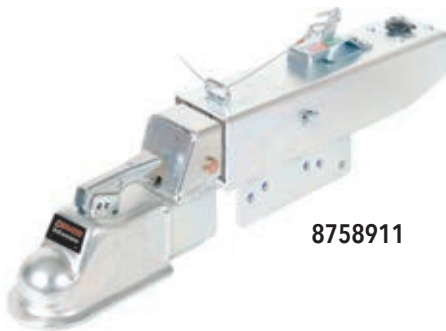

8758911

2" EZ LATCH

ITEM #	POSITION	OUTER CASE	COATING	NOTES	WT (LBS.)
8669113	Down	3 Hole Standard	Zinc		58

2 5/16" EZ LATCH

ITEM #	POSITION	OUTER CASE	COATING	NOTES	WT (LBS.)
8758811	Down	3 Hole Standard	Zinc		52
8750311	Down	5 Hole Standard	Zinc	Bypass	54
8758911	Down	5 Hole Standard	Zinc		52

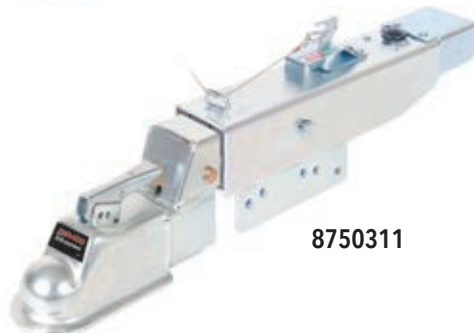

8750311

8" 4 BOLT CHANNEL (COUPLER NOT INCLUDED)

ITEM #	POSITION	OUTER CASE	COATING	NOTES	WT (LBS.)
8758721	Center	3 Hole Standard	Zinc		48
8759422	Center	3 Hole Standard	Primed	Inline Solenoid	49

Bypass solenoid kits for disc brakes (fit both DA91 and DA10 actuators).

5752	DA91	Solenoid Kit (factory installed)	2
5750	DA91	Solenoid Kit (field installed)	2

Blocking solenoid kit for disc brakes (fit both DA91 and DA10 actuators).

5837	DA91	Solenoid Kit (field installed)	2
------	------	--------------------------------	---

Note: Solenoid kit design is subject to change at Demco's discretion.

DA91 8000 LB. G.V.W.R. FOR DRUM BRAKES



8669112

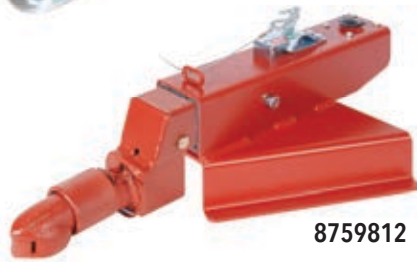

8759812

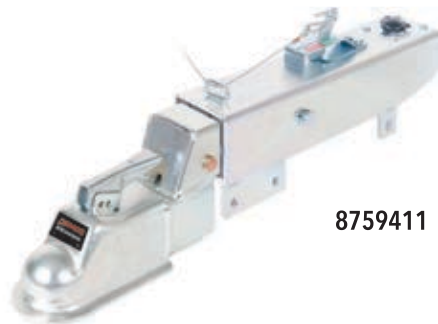

8759411



8759153

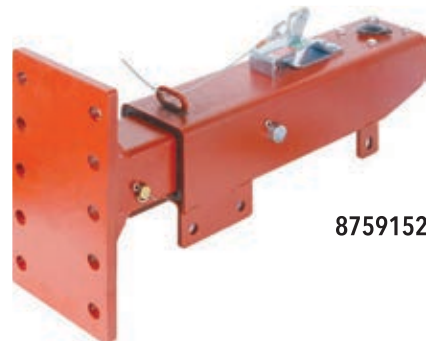

8759152

2" EZ LATCH

ITEM #	POSITION	OUTER CASE	COATING	NOTES	WT (LBS.)
8609502	Center	50° Mount	Primed		59
8609101	Center	3 Hole Standard	Zinc		41
8669112	Down	3 Hole Standard	Zinc		47

2 5/16" SLIDE-LOK

ITEM #	POSITION	OUTER CASE	COATING	NOTES	WT (LBS.)
8759802	Center	50° Mount	Primed		60
8759812	Down	50° Mount	Primed		62

2 5/16" EZ LATCH

ITEM #	POSITION	OUTER CASE	COATING	NOTES	WT (LBS.)
8759411	Down	3 Hole Standard	Zinc		58

FLAT PLATE (COUPLER NOT INCLUDED)

ITEM #	POSITION	OUTER CASE	COATING	NOTES	WT (LBS.)
8759152	Center	3 Hole Standard	Primed		39
8759153	Center	3 Hole	Zinc		40
8759552	Center	50° Mount	Primed		45

1/2" x 4 1/2" grade 5 bolts are required in mounting of straight actuators. 800 lb. maximum tongue load or 10% of G.V.W.R. of coupler, vehicle, ball or trailer. 50° A-frame mounted actuator may be welded on. Plated actuator may be used in a marine application. DA91 and DA9150 actuators utilize Acetal Copolymer linings. Rollers are eliminated.

G.V.W.R. – Limited to coupler rating. Emergency lever support and guide ring (on DA91 and DA95 series).

Custom mounting available upon request (50 quantity minimum).

ACTUATORS

DA91 8000 LB. G.V.W.R. FOR DRUM BRAKES

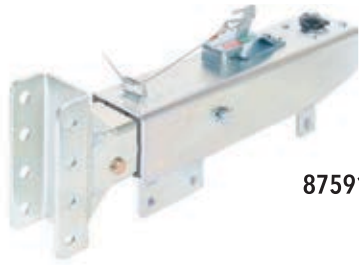

8759121

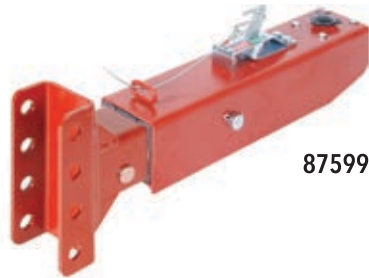

8759922



8759522

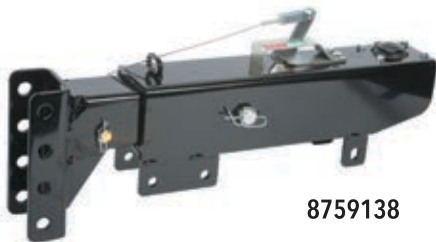

8759138



8758521

8" 4 BOLT CHANNEL (COUPLER NOT INCLUDED)

ITEM #	POSITION	OUTER CASE	COATING	NOTES	WT (LBS.)
8759231	Down	2 Hole	Zinc		52
8759241	Up	2 Hole	Zinc		52
8760011	Center	3 Hole Straight	Zinc	Lock Out	37
8760012	Center	3 Hole Straight	Silver	Lock Out	37
8759522	Center	50° Mount	Primed		45
8759532	Down	50° Mount	Primed		45
8759922	Center	Weld On	Primed		30
8759933	Down	Weld On	Primed	Lock Out	31
8759942	Up	Weld On	Primed		30
8759121	Center	3 Hole Standard	Zinc		32
8759122	Center	3 Hole Standard	Primed		32
8759122-30	Center	3 Hole Standard	Black		32
8759131	Down	3 Hole Standard	Zinc		32
8759132	Down	3 Hole Standard	Primed		32
8759138	Down	3 Hole Standard	Black		32
8759142	Up	3 Hole Standard	Primed		32

12" 6 BOLT CHANNEL (COUPLER NOT INCLUDED)

ITEM #	POSITION	OUTER CASE	COATING	NOTES	WT (LBS.)
8758521	Center	3 Hole Standard	Zinc		38
8759432	Down	Weld On	Primed	.024 Orifice	38

DA91 manual lockout

5939	DA91	Manual Lockout Kit (field installed)	25750
------	------	--------------------------------------	-------

Bypass solenoid kits for drum brakes

5751	DA91	Solenoid Kit
------	------	--------------

DISC BRAKE CONVERSION

(CONVERTS ANY DRUM BRAKE ACTUATOR TO DISC)

ITEM #	DESCRIPTION	WT (LBS.)
6116	DA91 Changes standard master cylinder to disc brake with a bypass (factory installed only)	2

DA10 12,500 LB. G.V.W.R. FOR DISC BRAKES



8104002



8104411

2 5/16" EZ LATCH

ITEM #	POSITION	OUTER CASE	COATING	NOTES	WT (LBS.)
8104002	Center	Weld on	Primed	Bypass	49
8104311	Down	5 Bolt Universal	Zinc	Bypass	53
8104411	Down	5 Bolt Universal	Zinc		53

8" 4 BOLT CHANNEL (COUPLER NOT INCLUDED)

ITEM #	POSITION	OUTER CASE	COATING	NOTES	WT (LBS.)
8103721	Center	5 Hole Standard	Zinc		52
8105422	Center	50° Mount	Primed		52

Bypass solenoid kits for drum brakes

5752 DA10 Solenoid Kit

DA10 12,500 LB. G.V.W.R. FOR DRUM BRAKES

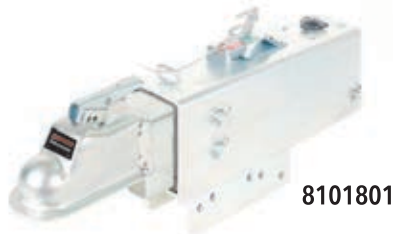

8101801



8102511

2 5/16" EZ LATCH

ITEM #	POSITION	OUTER CASE	COATING	NOTES	WT (LBS.)
8101801	Center	5 Hole Standard	Zinc		55
8101802	Center	5 Hole Standard	Primed		56
8102511	Down	5 Hole Standard	Zinc		54
8103102	Center	Weld On	Primed		49

FLAT PLATE (COUPLER NOT INCLUDED)

ITEM #	POSITION	OUTER CASE	COATING	WT (LBS.)
8101152	Center	Weld On	Primed	60
8101952	Center	Weld On Angle Mounts	Primed	58

1/2" x 4 1/2" grade 5 bolts are required to mount actuators. 1,250 lb. maximum tongue load or 10% of G.V.W.R. of coupler, vehicle, ball or trailer. 50° A-frame mounted actuator may be welded on. DA10 actuators utilize Acetal Copolymer linings. Rollers are eliminated. DA10 actuators may be ordered with or without various couplers. All DA10 models with coupler adjusting channels have 3" inside dimensions. Emergency lever guide and ring on DA10.

Custom mounting available upon request (50 quantity minimum).

ACTUATORS

DA10 12,500 LB. G.V.W.R. FOR DRUM BRAKES

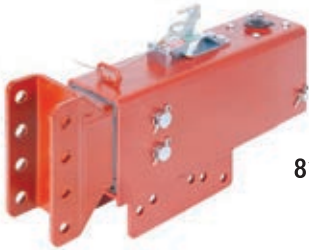

8101022

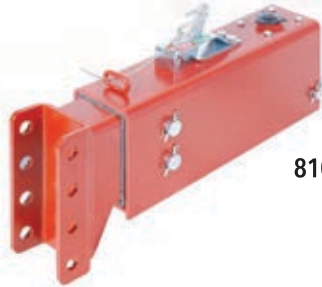

8101232



8102222



8101023



8101038



8101541

6" 2 BOLT CHANNEL (COUPLER NOT INCLUDED)

ITEM #	POSITION	OUTER CASE	COATING	NOTES	WT (LBS.)
8104811	Center	3 Hole Standard	Zinc		49

8" 4 BOLT CHANNEL (COUPLER NOT INCLUDED)

ITEM #	POSITION	OUTER CASE	COATING	NOTES	WT (LBS.)
8101021	Center	5 Hole Standard	Zinc		52
8101022	Center	5 Hole Standard	Primed		52
8101023	Center	5 Hole Standard	Black		52
8101031	Down	5 Hole Standard	Zinc		52
8101038	Down	5 Hole Standard	Black		52
8101042	Up	5 Hole Standard	Primed		52
8104821	Center	3 Hole Standard	Zinc		49
8104824	Center	3 Hole Standard	Silver		49
8104831	Down	3 Hole Standard	Zinc		49
8102222	Center	50° Mount	Primed		62
8102232	Down	50° Mount	Primed		62
8100122	Center	Angle Mount	Primed		50
8101222	Center	Weld On	Primed		50
8101232	Down	Weld On	Primed		50

12" 6 BOLT CHANNEL (COUPLER NOT INCLUDED)

ITEM #	POSITION	OUTER CASE	COATING	NOTES	WT (LBS.)
8102131	Down	5 Hole Standard	Zinc		55
8101532	Down	3 Hole Standard	Primed		54
8101541	Down	3 Hole Standard	Zinc	.031 orifice	50
8101522	Center	Weld On	Primed		53
8101523	Center	Weld On	Black		53
8103432	Down	Weld On	Primed		53

Bypass solenoid kits for drum brakes

5752	DA10	Solenoid Kit
------	------	--------------

DISC BRAKE CONVERSION

(CONVERTS ANY DRUM BRAKE ACTUATOR TO DISC)

ITEM #	DESCRIPTION	WT (LBS.)
6114	Changes standard master cylinder to large bore disc brake with a bypass. Installation includes replacement push rod (factory installed only)	2

DA16 16,000 LB. G.V.W.R. FOR DISC BRAKES



DA16 available in either weld-on or bolt-on mounts. 1,600 lb. maximum tongue load or 10% of G.V.W.R. of coupler, vehicle, ball or trailer. Emergency lever guide and guide ring on DA16.

2 5/16" EZ LATCH

ITEM #	POSITION	OUTER CASE	COATING	NOTES	WT (LBS.)
8164311	Down	5 Hole	Zinc	Bypass	87

DA20 20,000 LB. G.V.W.R. FOR DISC BRAKES

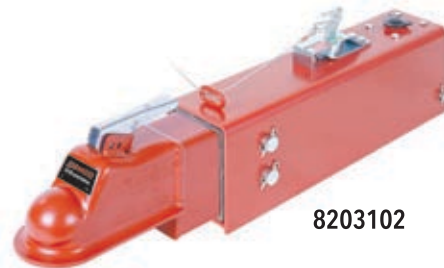

DA20 available in either weld-on or bolt-on mounts. 2,000 lb. maximum tongue load or 10% of G.V.W.R. of coupler, vehicle, ball or trailer. 50° A-frame mounted actuator may be welded on. DA20 actuators may be ordered with or without various couplers. All DA20 models with coupler adjusting channels have 3" inside dimensions. Emergency lever guide and guide ring on DA20.

Custom mounting available upon request (50 quantity minimum).

2 5/16" EZ LATCH

ITEM #	POSITION	OUTER CASE	COATING	NOTES	WT (LBS.)
8203102	Center	Weld On Tube Mount	Primed		70
8204311	Down	5 Hole	Zinc	Bypass	71
8204702	Center	Weld On	Primed	Bypass	70

FLAT PLATE (COUPLER NOT INCLUDED)

ITEM #	POSITION	OUTER CASE	COATING	NOTES	WT (LBS.)
8213718	Center	3 Hole Standard	Black	Bypass	65

NO CHANNEL SLIDER (COUPLER NOT INCLUDED)

ITEM #	POSITION	OUTER CASE	COATING	NOTES	WT (LBS.)
8205133	Bare	4" 5 Bolt Standard	Primed		69

8" 4 BOLT CHANNEL (COUPLER NOT INCLUDED)

ITEM #	POSITION	OUTER CASE	COATING	NOTES	WT (LBS.)
8205222	Center	50° Mount	Primed	Bypass	80
8205322	Center	50° Mount	Primed	Inline	80

Bypass solenoid kits for drum brakes.

5755 DA20 Solenoid Kit

ACTUATORS

DA20 20,000 LB. G.V.W.R. FOR DRUM BRAKES



8204011



8202932

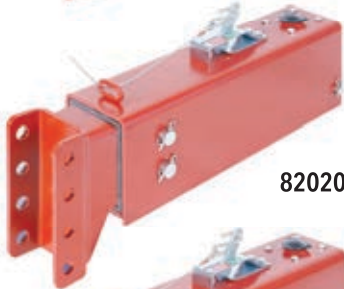

8202032

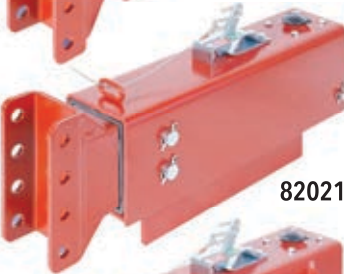

8202122

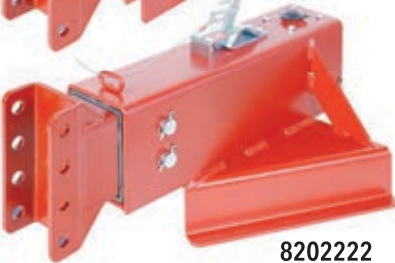

8202222

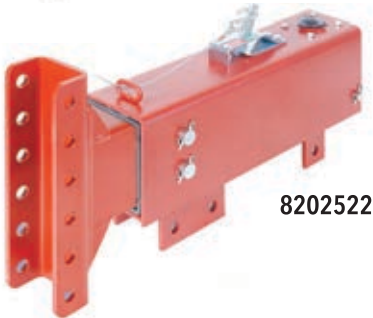

8202522

DA20 available in either weld-on or bolt-on mounts. 2,000 lb. maximum tongue load or 10% of G.V.W.R. of coupler, vehicle, ball or trailer. 50° A-frame mounted actuator may be welded on. DA20 actuators may be ordered with or without various couplers. All DA20 models with coupler adjusting channels have 3" inside dimensions. Emergency lever guide and guide ring on DA20.

2 5/16" EZ LATCH

ITEM #	POSITION	OUTER CASE	COATING	NOTES	WT (LBS.)
8204011	Down	5 Hole	Zinc		70

FLAT PLATE (COUPLER NOT INCLUDED)

ITEM #	POSITION	OUTER CASE	COATING	NOTES	WT (LBS.)
8202052	Center	Weld On	Primed		62
8202152	Center	Weld On Tube Mount	Primed		70

NO CHANNEL SLIDER (COUPLER NOT INCLUDED)

ITEM #	POSITION	OUTER CASE	COATING	NOTES	WT (LBS.)
8202932	Bare	Weld On	Primed		69

8" 4 BOLT CHANNEL (COUPLER NOT INCLUDED)

ITEM #	POSITION	OUTER CASE	COATING	NOTES	WT (LBS.)
8202022	Center	Weld On	Primed		59
8202023	Center	Weld On	Black		59
8202031	Center	5 Hole	Plated		59
8202032	Down	Weld On	Primed		59
8202042	Up	Weld On	Primed		59
8202122	Center	Weld On Tube Mount	Primed		70
8202132	Down	Weld On Tube Mount	Primed		70
8202222	Center	50° Mount	Primed		80
8202232	Down	50° Mount	Primed		80

12" 6 BOLT CHANNEL (COUPLER NOT INCLUDED)

ITEM #	POSITION	OUTER CASE	COATING	NOTES	WT (LBS.)
8202521	Center	3 Hole Standard	Zinc		72
8202522	Center	3 Hole Standard	Primed		72
8202531	Down	3 Hole Standard	Zinc		72
8202532	Down	3 Hole Standard	Primed		72
8203322	Center	Weld On	Primed		62
8203332	Down	Weld On	Primed		62
8204333	Down	5 Hole	Black		72

Bypass solenoid kits for drum brakes

5754 DA20 Solenoid Kit

DISC BRAKE CONVERSION

(CONVERTS ANY DRUM BRAKE ACTUATOR TO DISC)

ITEM #	DESCRIPTION	WT (LBS.)
6115	DA20 Changes standard master cylinder to large bore disc brake with a bypass. Installation includes replacement push rod (factory installed only)	2

ACTUATOR KITS: DA91 • DA10 • DA20

UNASSEMBLED ACTUATORS DA91, DA10, AND DA20

These actuators come unprimed and are unassembled for weld on applications. Parts come boxed for assembly after welding and paint.

ITEM #	POSITION	OUTER CASE	COATING	NOTES	SAME AS	WT (LBS.)
6106	8" Center	Weld On	None	DA91 Knocked Down	8759922	37
6050	8" Center	Weld On	None	DA10 Knocked Down	8101222	47
5930	12" Center	Weld On	None	DA10 Knocked Down	8101522	50
6049	8" Center	Weld On	None	DA20 Knocked Down	8202032	56
6086	12" Center	Weld On	None	DA20 Knocked Down	8203322	60
5947	12" Down	Weld On	None	DA20 Knocked Down	8203332	60
5541	Bare	Weld On	None	DA20 Knocked Down	8202932	50
6171	8" Up	Weld On	None	DA91 Knocked Down	8759942	30
6185	8" Up	Weld On	None	DA10 Knocked Down	8101042	30
6186	Flat Plate	Weld On	None	DA20 Knocked Down	8202052	62



ACTUATOR REPLACEMENT COMPONENTS FOR DISC AND DRUM BRAKES

BRAKE MASTER CYLINDER



Brake Master Cylinder
(Drum) 5650
(Disc) 5672



Brake Master Cylinder With Inline Solenoid
(Drum) 5921
(Disc) 5919



Brake Master Cylinder With Bypass Solenoid
(Drum) 5920
(Disc) 5918



Large Bore Aluminum Disc Brake Master Cylinder with Bypass Solenoid
(Disc) 6113



Replacement Inline Solenoid
11993



Replacement Bypass Solenoid
(Bypass Solenoid) 05561
(Bypass Solenoid Kit) 5404

COUPLERS

2" & 2 5/16" Tube Mount

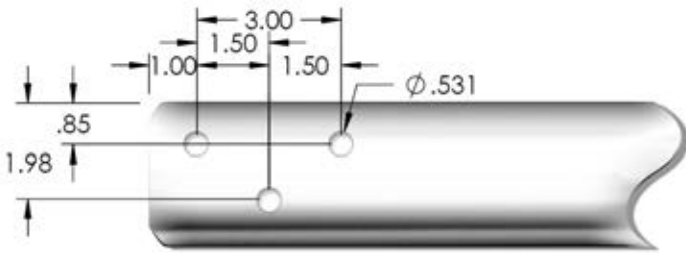

2" & 2 5/16" 50° A-Frame Mount

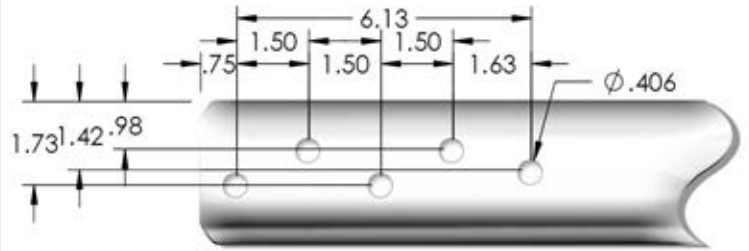

2" & 2 5/16" Tube Mount

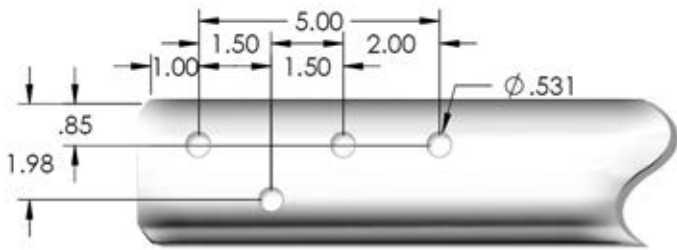

2" & 2 5/16" Tube Mount

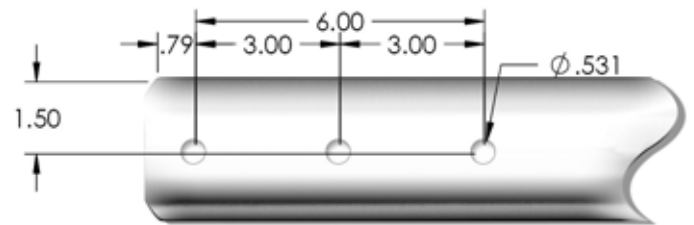

Flat Mount

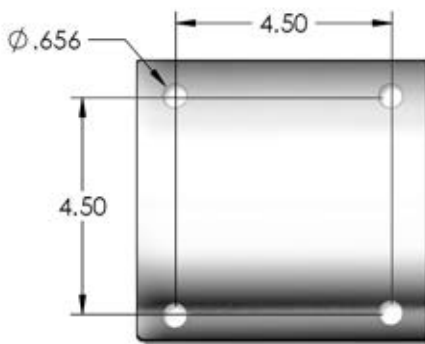

Channel Mount

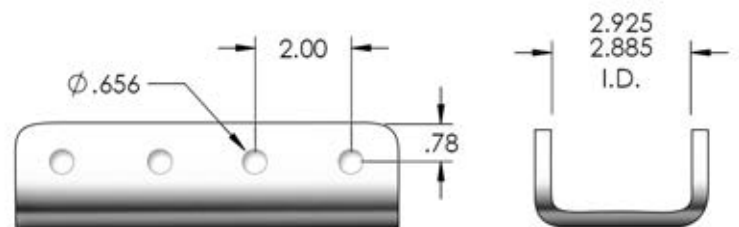

DEMCO

EZ LATCH COUPLER



Step 1
The EZ Latch coupler remains in its locked position. No need to open the coupler. Simply back under the coupler and start lowering it onto the ball.



Step 2
The coupler will automatically open to accept the hitch ball into the coupler socket.



Step 3
Once the trailer is completely lowered, the coupler will automatically lock around the hitch ball.

Demco's exclusive EZ Latch coupler design automatically latches when dropped onto a hitch ball.

- **SAFETY** - All Demco EZ Latch couplers exceed all required SAE J684 safety standards without the use of a safety pin.
- **SECURITY** - Never forget to latch your coupler again. Let our EZ Latch system bring you peace of mind when hooking up your next trailer.
- **MAINTENANCE FRIENDLY** - The EZ Latch System is a maintenance-free system. NO grease or adjustments needed.
- **VARIETY** - EZ Latch couplers are available in a variety of styles and weight ratings: channel mount, tube mount, and A-frame from 10,000 to 21,000 lb. G.V.W.R.

The EZ Latch coupler is offered in an array of different hitch mounts in both 2" and 2 5/16" ball coupler sizes

MOUNTING CONFIGURATIONS INCLUDE:

- Weld on or bolt on 3" tongue tube
- Weld on or bolt on A-frame
- Bolt-on adjustable height channel mounts



Demco 2" and 2 5/16" EZ Latch Couplers are Patent #76906732

NEW

DEMCO COUPLERS

2" CAST COUPLER LINE 10K G.V.W.R.



16825-81



16854-81



16698-81

2⁵/₁₆" COUPLERS

21K A-Frame with
Chain Anchor



16680-XX

21K Flat Mount



15923-XX

2⁵/₁₆" SLIDE-LOK COUPLERS 12.5K G.V.W.R.

2" SLIDE-LOK COUPLERS 7K G.V.W.R.



05823-95



05823-81



05557-95



05557-95



TOWING SOMEWHERE?

*Make sure your next coupler has the **EZ LATCH ADVANTAGE**
for a safe, secure connection the first time, every time.*

DEMCO

2" COUPLERS

2" BALL COUPLER 6000 LB. G.V.W.R.



12113-95 Zinc only

CHANNEL MOUNT

ITEM #	DESCRIPTION	WT (LBS.)
12113-95	2" lever lock, 6,000 lb. G.V.W.R. capacity, bolt on channel	7

2" BALL COUPLER 7000 LB. G.V.W.R.



05823-95

05823-81

CHANNEL MOUNT

ITEM #	DESCRIPTION	WT (LBS.)
05823-95	2" Slide-lok, Black, 7,000 lb. G.V.W.R. capacity, bolt on channel	12
05823-81	2" Slide-lok, Plated, 7,000 lb. G.V.W.R. capacity, bolt on channel	12

2" BALL COUPLER 7000 AND 10,000 LB. G.V.W.R.



12563 Primed only

12564 Zinc only

15000-XX

15945 Zinc only

12717 Zinc only

TUBE MOUNT

ITEM #	DESCRIPTION	WT (LBS.)
15629-XX	2" EZ LATCH, 10,000 lb. G.V.W.R. capacity, weld on composite handle	8
12563	Primed, 2" EZ LATCH, 10,000 lb. G.V.W.R. capacity, weld on	8
12564	Plated, 2" EZ LATCH, 10,000 lb. G.V.W.R. capacity, 3 hole bolt on	8
15000-XX	2" EZ LATCH, 10,000 lb. G.V.W.R. capacity, 4 hole bolt on composite handle	8
15945	2" EZ LATCH, 7000 lb. G.V.W.R. capacity, 3 hole bolt on	8
12717	Plated, 2" EZ LATCH, 10,000 lb. G.V.W.R. capacity, 4 hole bolt on	7
12925	Plated, 2" EZ LATCH, 10,000 lb. G.V.W.R. capacity, 3 hole bolt on short body	7
13689-XX	Silver, 2" EZ LATCH, 10,000 lb. G.V.W.R. capacity, 3 hole bolt on short body composite handle	7

NOTE: All Demco 2" EZ Latch Couplers are Patent #76906732.



12925 Zinc only

13689-XX

ITEM #	DESCRIPTION	WT (LBS.)
6166	Channel Mount Coupler Hardware Kit (contains 4 GR5 5/8 bolts, 4 washers, 4 lock nuts)	2

2" BALL COUPLER 10,000 LB. G.V.W.R.



12688-XX



14976-XX



15080-XX



16698-81



16854-81

CHANNEL MOUNT

ITEM #	DESCRIPTION	WT (LBS.)
12688-XX	2" EZ Latch, metal handle, 10,000 lb. G.V.W.R. capacity, bolt on channel, 4 bolt mount	9
14976-XX	2" EZ Latch, composite handle, 10,000 lb. G.V.W.R. capacity, bolt on channel, 4 bolt mount	9
16825-XX	2" Cast Channel Mount Coupler, composite handle, 10,000 lb. G.V.W.R. , 2 bolt mount	12



16825-XX

FLAT MOUNT

ITEM #	DESCRIPTION	WT (LBS.)
15080-XX	2" EZ Latch, 10,000 lb. G.V.W.R. capacity, flat mount 5/8" holes	13.5

50° MOUNT

ITEM #	DESCRIPTION	WT (LBS.)
15650-XX	Coupler 2" comp bolt on 5 hole silver metallic, 10,000 lb. G.V.W.R. (No picture)	20
16698	2" Cast A-frame, weld on, RAW, 10,000 lb. G.V.W.R. (No picture)	20
16698-81	2" Cast A-frame, weld on, black, 10,000 lb. G.V.W.R.	20
16854-81	2" Cast A-frame with chain anchor, 10,000 lb. G.V.W.R.	20
16908-81	2" Cast A-frame bolt on channel, 10,000 lb. G.V.W.R.	20

2" COUPLER REPAIR KITS



5876



5696

ITEM #	DESCRIPTION	WT (LBS.)
5696	Lever lock coupler repair kit 6000 lb. non EZ Latch	2
5876	EZ Latch coupler repair kit 10,000 lb. metal handle	2
6109	EZ Latch coupler repair kit 10,000 lb. composite handle	2
6317	Composite handle only	1

ITEM #	DESCRIPTION	WT (LBS.)
6166	Channel Mount Coupler Hardware Kit (contains 4 GR5 5/8 bolts, 4 washers, 4 lock nuts)	2

2 5/16" COUPLERS

2 5/16" BALL COUPLER 21,000 LB. G.V.W.R.



12662-97
Primed Only



15923-XX



12660-97
Primed Only



15337-97
Primed Only



16680-XX



15633-XX



6008

TUBE MOUNT

ITEM #	DESCRIPTION	WT (LBS.)
12662-97	Primed Only, 2 5/16" EZ Latch, 21,000 lb. G.V.W.R. capacity, weld on short body	8.5

FLAT MOUNT

ITEM #	DESCRIPTION	WT (LBS.)
15923-XX	2 5/16" EZ Latch, 21,000 lb. G.V.W.R. capacity, flat mount 5/8" holes	13.5
16759-XX	Composite handle, 21,000 lb. G.V.W.R. capacity, flat mount 3/4" holes	13.5

50° MOUNT - WELD ON

ITEM #	DESCRIPTION	WT (LBS.)
12660-97	Primed Only, 2 5/16" EZ Latch, 21,000 lb. G.V.W.R. capacity, A-frame weld on, with jack hole composite handle	12
15337-97	Primed Only, 2 5/16" EZ Latch, 21,000 lb. G.V.W.R. capacity, A-frame weld on, with jack hole metal handle	12
16399-XX	Primed Only, 2 5/16" EZ Latch, 12,500 lb. G.V.W.R. capacity, A-frame weld on, with jack hole composite handle	12

32° / 50° MOUNT - BOLT ON

ITEM #	DESCRIPTION	WT (LBS.)
16680-XX	50°, 2 5/16" EZ Latch, 21,000 lb. G.V.W.R. capacity, A-frame bolt on, with jack hole with chain anchors	17
15633-XX	32°, 2 5/16" EZ Latch, 21,000 lb. G.V.W.R. capacity, A-frame bolt on, with jack hole	17

2 5/16" COUPLER REPAIR KITS

ITEM #	DESCRIPTION	WT (LBS.)
5817	EZ Latch coupler repair kit metal handle	2
6008	EZ Latch coupler repair kit composite handle	2
6288	EZ Latch coupler repair kit for cast coupler	2

2 5/16" BALL COUPLER 12,500 LB. G.V.W.R.



CHANNEL MOUNT

ITEM #	DESCRIPTION	WT (LBS.)
05557-95	2 5/16" Slide-lok, 12,500 lb. G.V.W.R. capacity, bolt on channel	12
05557-81	2 5/16" Slide-lok, Black, 12,500 lb. G.V.W.R. capacity, bolt on channel	12

2 5/16" BALL COUPLER 18,000 AND 21,000 LB. G.V.W.R.



TUBE MOUNT

ITEM #	DESCRIPTION	WT (LBS.)
13203-XX	2 5/16" EZ Latch, 18,000 lb. G.V.W.R. capacity, bolt on channel	11
15931-XX	2 5/16" EZ Latch, 21,000 lb. G.V.W.R. capacity, bolt on channel	17
16080-XX	2 5/16" EZ Latch, 21,000 lb. G.V.W.R. capacity, 5 bolt on channel	19

2 5/16" CHANNEL MOUNT BALL COUPLER 20,000 AND 21,000 LB. G.V.W.R.



CHANNEL MOUNT CAST COUPLER

ITEM #	DESCRIPTION	WT (LBS.)
14040-XX	2 5/16" EZ Latch, 21,000 lb. G.V.W.R. capacity, bolt on composite handle	9
15791-XX	2 5/16" EZ Latch, 21,000 lb. G.V.W.R. capacity, bolt on metal handle	9

15791 CAST COUPLER WITH CHANNEL

ITEM #	DESCRIPTION	WT (LBS.)
6178-XX	2 5/16" EZ Latch, channel mount 12" 6 hole	18
6184-XX	2 5/16" EZ Latch, channel mount 8" 4 hole	16
6315-XX	2 5/16" EZ Latch, channel mount 12" 6 hole w/hardware	19

ITEM #	DESCRIPTION	WT (LBS.)
6166	Channel Mount Coupler Hardware Kit (contains 4 GR5 5/8" bolts, 4 washers, 4 lock nuts)	2

COUPLERS

COMBO COUPLERS AND CHANNELS 20,000 AND 21,000 LB. G.V.W.R.



14040 COUPLER CHANNELS

ITEM #	DESCRIPTION	WT (LBS.)
6167-XX	2 5/16" EZ Latch, 20,000 G.V.W.R. capacity, channel mount 12" 6 hole .375" channel without bolts	18
6124-XX	2 5/16" EZ Latch, 20,000 G.V.W.R. capacity, channel mount 8" 4 hole without bolts	18
6125-XX	2 5/16" EZ Latch, 21,000 G.V.W.R. capacity, channel mount 12" 6 hole .5" channel with bolts and gussets	21

PINTLE RING 25,000 LB. G.V.W.R.



PINTLE RING CHANNEL MOUNT

ITEM #	DESCRIPTION	WT (LBS.)
09557-XX	Pintle ring, 3" ID, 6" OD, 25,000 lb. G.V.W.R. capacity, bolt on channel	12
6135-XX	Pintle ring, 3" ID, 6" OD, 25,000 lb. G.V.W.R. capacity, bolt on channel with 12" 20,000 lb. channel and hardware	12

CHANNELS 7500-21,000 LB. G.V.W.R.



WELD-ON CHANNEL BRACKETS 8"

4 Hole (Hole spacing 2" centers) 8" over-all length.

ITEM #	WT (LBS.) MIN-MAX ID	CHANNEL THICKNESS	WEIGHT RATING	WT (LBS.)
55342	2.885" -2.925"	.25"	7,500 lbs.	4
55289	2.885" -2.925"	.313"	12,500 lbs.	5
57362	2.885" -2.925"	.375"	20,000 lbs.	5
66736	2.885" -2.925"	.5" Grade 80	21,000 lbs.	5



WELD-ON CHANNEL BRACKETS 12"

6 Hole (Hole spacing 2" centers) 12" over-all length.

ITEM #	WT (LBS.) MIN-MAX ID	CHANNEL THICKNESS	WEIGHT RATING	WT (LBS.)
59601	2.885" -2.925"	.313"	12,500 lbs.	7
59602	2.885" -2.925"	.375"	20,000 lbs.	8
66134	2.885" -2.925"	.5"	21,000 lbs.	9

CHANNEL MOUNTS 12,000 AND 14,000 LB. G.V.W.R.

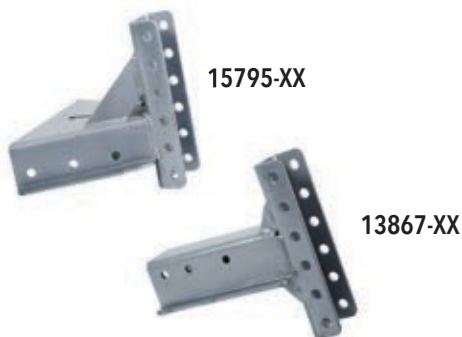

CHANNEL MOUNT

ITEM #	DESCRIPTION	WT (LBS.)
15795-52	A-frame channel mount bolt on with jack hole 14,000 lb. G.V.W.R. capacity	20
15349-52	A-frame channel mount bolt on without jack hole 14,000 lb. G.V.W.R. capacity (no picture)	20
13867-52	3" tube channel mount bolt on 12,000 lb. G.V.W.R. capacity	16
15974-52	A-frame channel mount without jack hole channel down, 14,000 lb. G.V.W.R. capacity (no picture)	20

CLEVIS COUPLER AND TONGUES

CLEVIS COUPLER 10,000 AND 20,000 LB. G.V.W.R.



05593-XX



12676-XX

CLEVIS CHANNEL MOUNT

ITEM #	DESCRIPTION	WT (LBS.)
05593-XX	Clevis, 10,000 lb. G.V.W.R. capacity, bolt on channel	11
12676-XX	Clevis, 20,000 lb. G.V.W.R. capacity, bolt on channel	12

TONGUES FOR AGRICULTURAL RUNNING GEARS OR DROP TONGUE TRAILERS



07686

12 TON G.V.W.R. BOLT-ON

ITEM #	TYPE	DESCRIPTION	WT (LBS.)
07686	DA12	Painted black, agricultural gear actuator	23



5976

13 TON G.V.W.R.

Telescoping tongues - 77.5" overall length, 17.75" telescope

ITEM #	TYPE	DESCRIPTION	WT (LBS.)
5976	Tongue	Raw tongue assembly without brakes, 2 bolt center channel, no mounts	89
5967	Tongue	Raw tongue assembly with brakes, 2 bolt center channel, no mounts	93
6173	Tongue	Raw Tongue assembly with brakes, clevis no mounts	109



5967

24 TON G.V.W.R. A-FRAME

Telescoping A-Frame tongues - 86" overall length, 17.75" Telescope 2" mounting tabs needed 31.25" on center.

ITEM #	TYPE	DESCRIPTION	WT (LBS.)
6133-81	A-Frame	Tongue Gloss Black Assembled with Brakes, Clevis, A-Frame	260
6133-71	A-Frame	Tongue Gloss Red Assembled with Brakes, Clevis, A-Frame	260
6134-81	A-Frame	Tongue Gloss Black Assembled without Brakes, Clevis, A-Frame	235
6134-71	A-Frame	Tongue Gloss Red Assembled without Brakes, Clevis, A-Frame	235



6133-81



6133-71

24 TON G.V.W.R.

Telescoping tongues - 77.5" overall length 17.75 telescope.

ITEM #	TYPE	DESCRIPTION	WT (LBS.)
5730	Tongue	Raw tongue assembly without brakes, clevis, no mounts	143
6030	Tongue	Raw tongue unassembled without brakes, clevis, no mounts	143
5597	Tongue	Raw tongue assembly with brakes, clevis, no mounts	165
6029	Tongue	Raw tongue unassembled with brakes, clevis, no mounts	167
6182	Tongue	Raw tongue assembly with manual lock-out brakes, clevis, no mounts	165
6181	Tongue	Raw tongue unassembled with manual lock-out brakes, clevis, no mounts	167



5730



5597

HYDRAULIC BRAKE ASSEMBLIES

10" HYDRAULIC BRAKE ASSEMBLIES

10" Free Backing Brakes



Reverse Braking – Minimal
Axle Rating – 3500 lbs.
Wheel Size – 13 - 15"

FREE BACKING BRAKES

Incorporates a "fall-away" shoe which diminishes shoe drag when backing up. Requires periodic manual adjustment. Marine cluster has galvanized back plate, stainless steel spring hardware, plated wheel cylinder and riveted marine brake shoe.

PRODUCT	RIGHT#	LEFT#	BOLT HOLE PATTERN	WT (LBS.)
Marine	SB40715M	SB40716M	4" on 4"	10

PRODUCT	TYPE	DESCRIPTION
Shoe Kit	07812	2 Front - 2 Rear

10" Uni-Servo Brakes



Reverse Braking – 15 - 20%
Axle Rating – 3500 lbs.
Wheel Size – 13 - 15"

UNI-SERVO BRAKES

20% braking in reverse. Requires periodic manual adjusting. Marine cluster has galvanized back plate, stainless steel spring hardware, plated wheel cylinder and riveted marine brake shoe.

PRODUCT	RIGHT#	LEFT#	BOLT HOLE PATTERN	WT (LBS.)
Marine	SB18787M	SB18788M	4" on 4"	10

PRODUCT	TYPE	DESCRIPTION
Shoe Kit	07811	2 Front - 2 Rear

10" Duo-Servo Brakes



Reverse Braking – 100%
Axle Rating – 3500 lbs.
Wheel Size – 13 - 15"

DUO-SERVO BRAKES

Applies braking pressure equally in forward or reverse travel. Primarily for industrial applications. Requires periodic manual adjustment. Marine cluster has galvanized back plate, stainless steel spring hardware, plated wheel cylinder and riveted marine brake shoe.

PRODUCT	RIGHT#	LEFT#	BOLT HOLE PATTERN	WT (LBS.)
Marine	SB18793M	SB18794M	4" on 4"	9.2

PRODUCT	TYPE	DESCRIPTION
Shoe Kit	07811	2 Front - 2 Rear

HYDRAULIC BRAKE ASSEMBLIES

12" HYDRAULIC BRAKE ASSEMBLIES

12" Free Backing



FREE BACKING BRAKES

Reverse braking - minimal. Axle rating - 5,200 lb. Wheel size - 14.5" - 16"
Marine cluster has galvanized back plate, stainless steel spring hardware, plated wheel cylinder and riveted marine brake shoe.

PRODUCT	RIGHT#	LEFT#	BOLT HOLE PATTERN	WT (LBS.)
Marine	SB42028M	SB42029M	5 on 3.875"	19

PRODUCT	TYPE	DESCRIPTION
Shoe Kit	07814	2 Front - 2 Rear

12" Uni-Servo



UNI-SERVO BRAKES

Reverse braking - 15 - 20%. Axle rating - 5,200 lb. Wheel size - 14.5" - 16"
Marine cluster has galvanized back plate, stainless steel spring hardware, plated wheel cylinder and riveted marine brake shoe.

PRODUCT	RIGHT#	LEFT#	BOLT HOLE PATTERN	WT (LBS.)
Marine	SB23510M	SB23511M	5 on 3.875"	19

PRODUCT	TYPE	DESCRIPTION
Shoe Kit	07813	2 Front - 2 Rear

DRUMS FOR BRAKE ASSEMBLIES



11777

10" BRAKE DRUMS

ITEM#	DICO ITEM#	# OF BOLTS	BOLT HOLE DIA.	BOLT CIRCLE DIA.	PILOT HOLE DIA.	STYLE	WT (LBS.)
11777	NA	5	1/2"	5 1/2"	4"	A	12



13717

12" BRAKE DRUMS

ITEM#	DICO ITEM#	# OF BOLTS	BOLT HOLE DIA.	BOLT CIRCLE DIA.	PILOT HOLE DIA.	STYLE	WT (LBS.)
13717	NA	6	5/8"	5 1/2"	4 3/8"	B	14

HYDRAULIC BRAKE ASSEMBLIES

13" HYDRAULIC BRAKE ASSEMBLIES



01971

13" BRAKE CLUSTERS

Free Backing Brakes (shown)

Reverse braking - minimal.

Wheel size - 16" - 22.5"

PRODUCT	RIGHT#	LEFT#	BOLT HOLE PATTERN	WT (LBS.)
Standard	01971	01970	4 on 4.813"	21

PRODUCT	TYPE	DESCRIPTION
Shoe Kit	5508	2 Front - 2 Rear

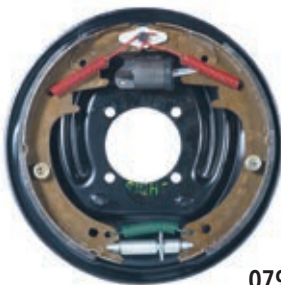

07911

13" UNI-SERVO BRAKE CLUSTERS

Uni-Servo Brakes (shown)

Reverse braking - 15 - 20%.

Wheel size - 16" - 22.5"

PRODUCT	RIGHT#	LEFT#	BOLT HOLE PATTERN	WT (LBS.)
Standard	07911	07910	4 on 4.813"	21

PRODUCT	TYPE	DESCRIPTION
Shoe Kit	5509	2 Front - 2 Rear



07324



03532

13" BRAKE DRUMS

ITEM#	DICO ITEM#	# OF BOLTS	BOLT HOLE DIA.	BOLT CIRCLE DIA.	PILOT HOLE DIA.	STYLE	WT (LBS.)
05353	9894	8	5/8"	8"	5 3/4"	A	20.6
07324	16964	6	17/32"	8 1/4"	6"	A	20.3
03532	18859	8	17/32"	5 1/2"	4 3/8"	B	22.5
03940	10111	6	17/32"	5 1/2"	4 3/8"	B	22.6
03941	43268	8	17/32"	5 1/2"	4 1/2"	B	21.9

BRAKE FLANGES



54988

60124

52415

61715

59911

ITEM#	PLATE DIMENSIONS	PILOT HOLE	PILOT
54988	.25" X 4.25" X 4.25" - 4 ON 4.813"	21/2"	.91
60124	.25" X 4.25" X 4.25" - 4 ON 4.813"	23/4"	.91
52415	.25" X 4.25" X 4.25" - 4 ON 4.813"	3"	.84
61715	.25" X 4.25" X 4.25" - 4 ON 4.813"	31/4"	.76
59911	.25" X 4.25" X 4.25" - 4 ON 4.813"	31/2"	.65

BRAKE LINE KITS

SINGLE SOLID AXLE KIT

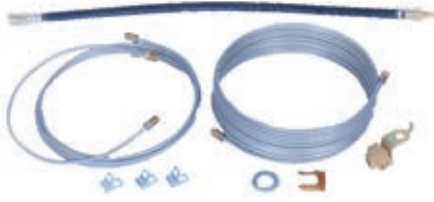

ITEM #	DESCRIPTION	WT (LBS.)
6097	180" Main Line With 72" and 30" Lines	2
5402	193" Main Line With 66" and 17" Lines	2
5426	193" Main Line With 80" and 17" Lines	2
5427	193" Main Line With 72" and 17" Lines	2.5
5643	240" Main Line With 66" and 17" Lines	2.5



SINGLE TORSION AXLE KIT

ITEM #	DESCRIPTION	WT (LBS.)
5424	193" Main Line With 66" and 17" Lines	3



TANDEM SOLID AXLE KIT

ITEM #	DESCRIPTION	WT (LBS.)
6098	180" Main Line With 72" and 30" Lines	4
5951	193" Main Line With 80" and 17" Lines	4
5403	193" Main Line With 66" and 17" Lines	4
5428	193" Main Line With 72" and 17" Lines	4
5429	193" Main Line With 80" and 17" Lines	4
6064	193" Main Line With 66" and 4.5" Lines	4



TANDEM TORSION AXLE KIT

ITEM #	DESCRIPTION	WT (LBS.)
5425	193" Main Line With 66" and 17" Lines	4

ACTUATOR BRAKE BLEEDER



10142

ITEM #	DESCRIPTION	WT (LBS.)
10142	Master cylinder adapter for use with power bleeder (Rubber washer included)	1
09215	Rubber washer	

BRAKE LINES

BRAKE LINE COMPONENTS

HARD LINES

.188 Double Flared Aluminum Galfan

ITEM #	LENGTH	DESCRIPTION	ITEM #	LENGTH	DESCRIPTION
SB5045	4 1/2		SB553	53	
11968	6		SB560	60	
SB508	8		SB566	66	
SB512	12		SB572	72	
SB517	17		SB580	80	
SB520	20		SB590	90	
09098	24		SB597	97	
SB530	30		SB5120	120	
SB532	32		07913	128	Armored Galfan Metal
SB536	36		SB5180	180	
SB537	37		SB5193	193	
SB540	40		SB5230	230	
SB541	41		SB5240	240	
SB550	50				

FLEXIBLE BRAKE HOSES

SAE 1401

ITEM #	LENGTH	DESCRIPTION	ITEM #	LENGTH	DESCRIPTION
SB7H66	7	Solid Female (2x)	09571	24	Solid Male & Female
SB7H67	7	Swivel Male & Solid Female	11876	25	Solid Female Swivel Male with 90°
10433	9	Solid Female (2x)			Line
02032	12	Solid Male & Solid Female	11714	27	Solid Male Solid Female
SB12H137	12	Solid Male & Solid Male	13858	28	Swivel Male with 90° & Solid Female
SB13H66	13	Solid Female	11738	36	Double Swivel Male With
13958	17	90° Swivel Male Ends (2x)			Coiled Armor Spring
SB18H137	18	Solid Male & Swivel Male	15009	36	Swivel Male & Solid Female
11627	18	Swivel Male with 90° & Solid Female	02034	45	Solid Female (2x)
05982	19	Solid Male & Solid Female	05979	52	Swivel Male & Swivel Male
13788	20	1/2 Solid Male & Solid Female	14006	62 45°	Elbow Male & Solid Male
SB24H137	24	Solid Male & Swivel Male			

BRAKE ACCESSORIES

ITEM #	DESCRIPTION
02549	Brake line protector rubber x .75" long
SB7764	Brake line clip
05981-95	Bracket pltd for brake line hose
01863	5/8 Rubber grommet

FITTINGS

ITEM #	DESCRIPTION
10375	Ftg .125 MPT X .125 MPT nipple
10737	Ftg Elb .125 MPT X .125 FPT 90° street elbow
10376	Ftg Elb .125 MPT X .20 HB brass
10373	Ftg Str .20 Hb X 10-32 NF Tapered brass
SB7785	Ftg Tee .188 inverted flare with bracket
SB7900	Ftg Tee .188" adapter female (2) male (1)
SBD10	Ftg union .188" female
11436	Ftg .125 MPT X .125 FPT elbow
05679	Ftg .125" MPT X .188" inverted flare

SPARE TIRE MOUNTS



15850 STAKE POCKET MOUNT

ITEM #	DESCRIPTION
15850-XX	Stake Pocket Spare Tire Holder - Fits 2x4 standard stake pocket up to 3" deep . Accepts bolt patterns from 2.5" - 6.5"
15884-XX	Stake Pocket Spare Tire Holder with 4" offset - Fits standard stake pocket up to 3" deep. Accepts bolt patterns from 2.5" - 6.5"



15851 TONGUE MOUNT

ITEM #	DESCRIPTION
15851-XX	Vertical Spare Tire Holder - Fits trailer tongues up to 4"x4". Accepts bolt patterns from 2.5"-6.5"



15853 JACK MOUNT

ITEM #	DESCRIPTION
15853-XX	Universal Jack Mount Spare Tire Holder - will mount opposite of bolt on swivel jacks. Accepts bolt patterns from 2.5"-6.5"

Tire mounts are available in 2 coating options:



Silver: -52

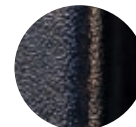

Black Texture: -76

PARTS EXPLOSIONS

DA66 PARTS EXPLOSION

8605001 DRUM BRAKE 8605101 DISC BRAKE ACTUATOR PARTS

Do not tighten these bolts. They are factory torqued and must remain loose enough to allow free coupler movement.

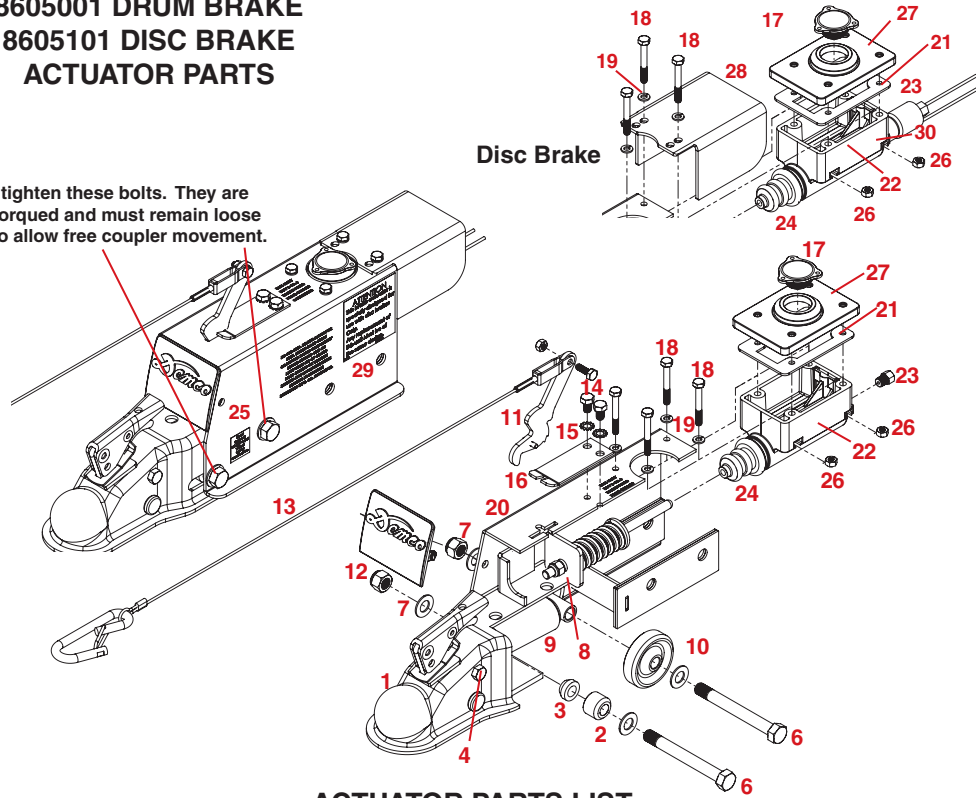

ACTUATOR PARTS LIST

REF NO.	PART NO.	QTY	DESCRIPTION
1.	12190-95	1	6000# 2" Lever Lock Coupler
2.	SB23278	2	Roller
3.	12151	2	Front Roller Spacer
4.	02166	1	3/8"-16UNC X 2-3/7" Hex Head Bolt (gr.5)
5.	07176	1	3/8"-16UNC Stover Lock Nut
6.	05684	2	1/2"-13UNC x 4-7/16" Hex Head Bolt (gr.5)
7.	02178	2	1/2"-13UNC Nylon Insert Lock Nut
8.	12193	1	Push Rod Assembly
9.	05692	1	Dampener/ Shock
10.	12103	2	Rear Roller Spacer
11.	*05951	1	Emergency Lever
12.	12187	1	Front Cover Composite Black
13.	*12200	1	28" Cable
14.	05960	2	5/16"-18UNC x 1/2" Self-Tapping Screw
15.	05424	2	5/16" External Tooth Lock Washer
16.	*05693-95	1	Emergency Lever Spring
17.	03876	1	Master Cylinder Cap w/ Diaphragm & O-ring
18.	**00618	4	1/4-20UNC x 2.00" Hex Head Bolt
19.	**00057	4	1/4" Spring Lock Washer

Please order replacement parts by PART NO. & DESCRIPTION

REF NO.	PART NO.	QTY	DESCRIPTION
20.	12191-95	1	Outer Case
21.	**09153	1	Replacement Master Cyl. Gasket ONLY
22.	**10616	1	Master Cylinder (Not sold separately) Drum
-	5650	-	Master Cylinder Drum Kit (incl. items w/**)
-	**11190	1	Master Cylinder (Not sold separately) Disc
-	5672	-	Master Cylinder Disc Kit (incl. items w/**)
23.	05679	1	.125 Full Orifice Drum
-	11993	1	Inline Blocking Solenoid Disc
24.	**05687	1	Master Cylinder Protective Boot
25.	BH21004	1	Safety Decal (See Page 6)
26.	**00062	4	1/4-20UNC Nut
27.	12557	1	Threaded Cap For Master Cylinder
28.	12267-95	1	Solenoid Cover Disc
29.	BD21001	2	Disc Brakes Decal (See Page 6)
30.	07283	1	10mm Flat Washer Disc

Please order replacement parts by PART NO. & DESCRIPTION

DA75 PARTS EXPLOSION

Item	Part #	Description	Qty
1	00057	Washer, .25 Spring Lock	6
2	00092	Bolt .25NC x .50 Hex Head Gr.5	2
3	00173	Nut .50HC Center Punch Hex	2
4	00618	Bolt .25NC x 2.00 Hex Head Gr.5	4
5	01896	Bolt .50NC x 4.00 Hex Head Gr.5	2
6	02207	Bolt .375NC x 3.00 Gr.5	1
7	02592	Nut .375NC Nylon Lock	1
8	02769	Bolt .375NC x 4.00 Hex Head Gr.5	1
9	03876	Master Cylinder Cap Assembly	1
10	04886	Nut .75 Jam	1
11	05679	Brake Fitting .125 Full Flow	1
12	05692	Shock, Dampener	1
13	09153	Cork Gasket F/ Master Cylinder	1
14	10616	Composite Master Cylinder Drum	1
15	12020	eZ-Latch Lever Spring	1
16	12557	Cap F/ Master Cylinder	1
17	13186	Screw .25-20 x .625SS Socket Button	3

18	13427	Top Latch	1
19	13690	Pin .1875 x 1.750 Spirol	1
20	13765	Square Clamp Stem	1
21	14041	Ball Clamp F/ Cast Coupler	1
22	15681	2" 7.5K Inner Slide	2
23	15682	ESL Release Button	1
24	15683	7K Slide Rail	2
25	15797	7.5K Inline Outer Case	1
26	15798	7K Spring Plate	1
27	15803	7.5K Push Rod	1
28	15856	7K Safety Hook Assembly	1
29	15857	7K Safety Cable Repair	1

**** (OPTIONAL) BRAKE FITTING**
 05679 - .125 Full Flow
 SB12099 - .031 Orifice
 SB12100 - .024 Orifice
 SB12098 - .016 Orifice

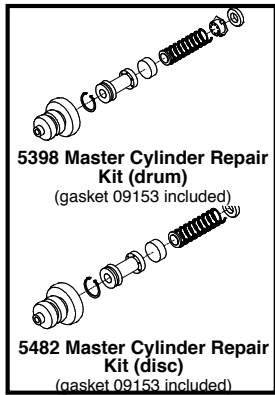
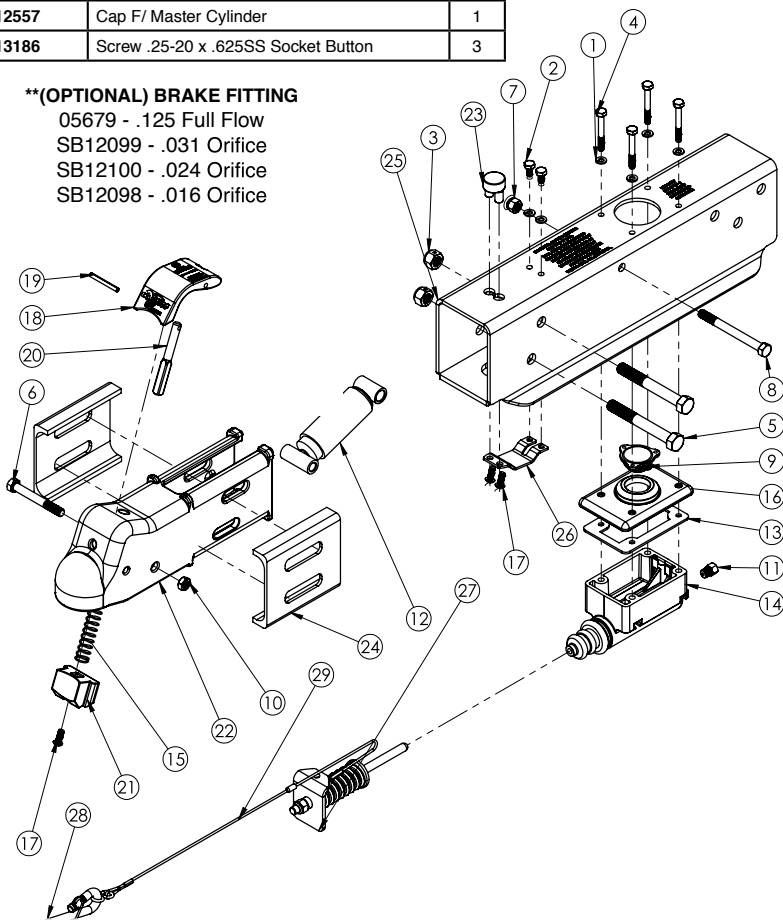

5650 Master Cyl. Replacement Kit (drum)
 (gasket 09153 and fasteners included)

5672 Master Cyl. Replacement Kit (disc)
 (gasket 09153 and fasteners included)

PARTS EXPLOSIONS

DA91 PARTS EXPLOSION

ACTUATOR PARTS BREAKDOWN

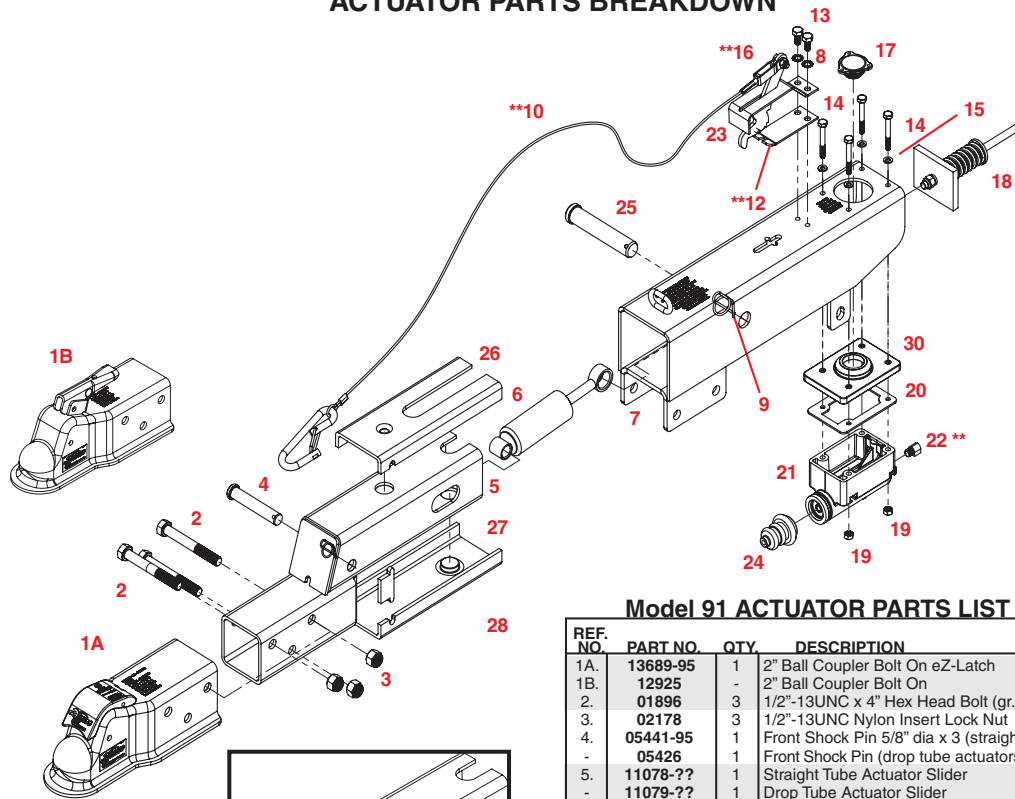

Model 91 ACTUATOR PARTS LIST

REF. NO.	PART NO.	QTY.	DESCRIPTION
1A.	13689-95	1	2" Ball Coupler Bolt On eZ-Latch
1B.	12925	-	2" Ball Coupler Bolt On
2.	01896	3	1/2"-13UNC x 4" Hex Head Bolt (gr.5)
3.	02178	3	1/2"-13UNC Nylon Insert Lock Nut
4.	05441-95	1	Front Shock Pin 5/8" dia x 3 (straight tube)
-	05426	1	Front Shock Pin (drop tube actuators)
5.	11078-??	1	Straight Tube Actuator Slider
-	11079-??	1	Drop Tube Actuator Slider
6.	SB12426	1	Dampener/ Shock
7.	11164-??	1	3 Bolt Mount Outer Case
8.	05424	2	5/16" External Tooth Lock Washer
9.	12397	1	Rue Ring Lock Cotter Pin f/.88 pin
**10.	05408	1	Replacement 3/32" Cable with bolt and nut
**12.	05693-95	1	Emergency Lever Spring
13.	05961	2	5/16"-18UNC x 5/8" Hex Head Bolt (gr.5)
14.	00618	4	1/4"-20UNC x 2" Hex Head Bolt (gr.5)
15.	00057	4	1/4" Lock Washer
**16.	05951-95	1	Emergency Lever Assembly
17.	03876	1	Master Cylinder Cap w/ Diaphragm & O-ring
-	05849	1	O-Ring Only (not shown)
18.	05977	1	Push Rod Assembly
19.	00062	4	1/4"-20 UNC Hex Nut
20.	09153	-	Master Cyl. Gasket ONLY
21.	5650	1	Master Cylinder (drum brakes)
-	5672	-	Master Cylinder (disc brakes)
**22.	05679	1	Brake Fitting .125 Full Flow (see options)
23.	03866-95	1	Lever Guide
24.	05687	1	Master Cylinder Protective Boot
25.	05986-95	1	Connecting Pin
26.	10965****	1	Upper Slider
27.	10966****	1	Lower Slider
28.	10967****	2	Side Spacers
29.	12396	1	Rue Ring Lock Cotter Pin f/.63 pin
30.	12557	1	Fill Plate for Master Cylinder

-	5401	-	Lever Replacement Kit (incl. items w/**)
-	5650	-	Master Cyl. Replacement Kit (drum)
-	5672	-	Master Cyl Replacement Kit (disc)
-	5942	-	Slide Replacement Kit (incl. items w/***)
-	5939	-	Manual Free Back Lock Out Kit

Note: -?? = -95 Plated -97 Primed Red -81 Black
-52 Metallic Silver

Please order replacement parts by **PART NO.** and **DESCRIPTION**

DA86 PARTS EXPLOSION

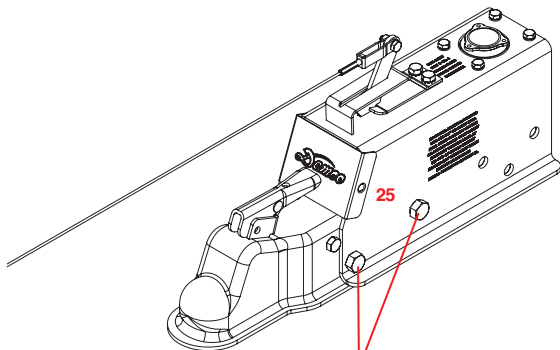

Do not tighten these bolts. They are factory torqued and must remain loose enough to allow free coupler movement.

8608601 *Plated & 8608701 *Black DRUM BRAKE ACTUATOR PARTS

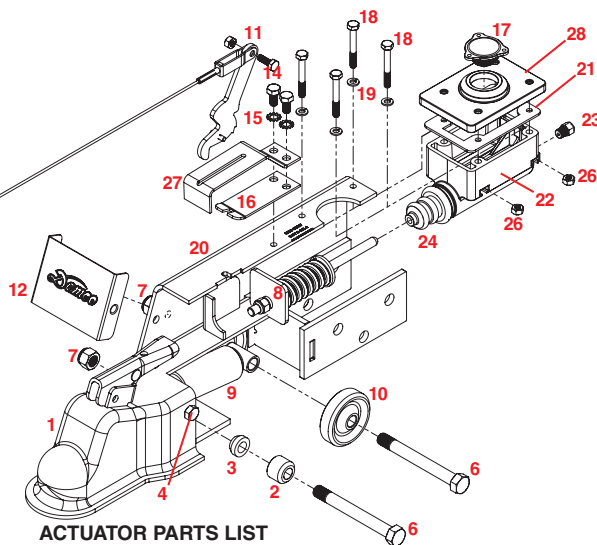

ACTUATOR PARTS LIST

REF. NO.	PART NO.	QTY.	DESCRIPTION
1.	12546-95	1	2" EZ-Latch Coupler Plated
-	12546-30	-	2" EZ-Latch Coupler Black
2.	SB23278	2	Roller
3.	12151	2	Front Roller Spacer
4.	08108	1	3/8"-16UNC X 2-3/7" Hex Head Bolt (gr.5)
5.	07176	1	3/8"-16UNC Stover Lock Nut
6.	05684	2	1/2"-13UNC x 4-7/16" Hex Head Bolt (gr.5)
7.	02178	2	1/2"-13UNC Nylon Insert Lock Nut
8.	12193	1	Push Rod Assembly
9.	05692	1	Dampener/ Shock
10.	12103	2	Rear Roller Spacer
11.	*05951	1	Emergency Lever
12.	12548-95	1	Front Cover
13.	*12200	1	28" Cable
14.	05961	2	5/16"-18UNC x 5/8" Screw
15.	05424	2	5/16" External Tooth Lock Washer
16.	*05693-95	1	Emergency Lever Spring
17.	03876	1	Master Cylinder Cap w/ Diaphragm & O-ring
18.	**00618	4	1/4"-20UNC x 2.00" Hex Head Bolt
19.	**00057	4	1/4" Spring Lock Washer
20.	12547-95	1	Outer Case Plated
-	12547-30	1	Outer Case Black
21.	**09153	1	Replacement Master Cyl. Gasket ONLY
22.	**10616	1	Master Cylinder (Not sold separately)
	5650	-	Master Cylinder Drum Kit (incl.items w/**)
23.	05679	1	Full Port Fitting
24.	05687	1	Master Cylinder Protective Boot
25.	BH21004	1	Safety Decal (See Page 7)
26.	**00062	4	1/4"-20UNC Nut
27.	03866	1	Emergency Lever Guide
28.	12557	1	Cap For Master Cylinder

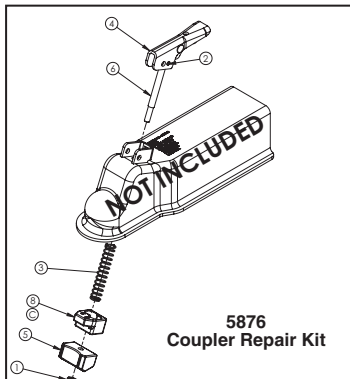
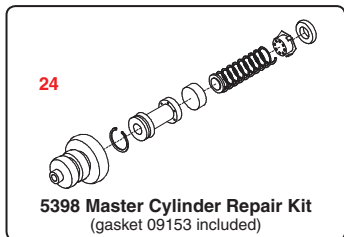

-	5400- Emergency Lever Replacement Kit (incl. items w/**)
-	5398 -Master Cylinder Repair Kit w/ gasket
-	5876 -Coupler Repair Kit (lever lock)

Please order replacement parts by PART NO. and DESCRIPTION.

PARTS EXPLOSIONS

DA10 PARTS EXPLOSION

MODEL DA10 ACTUATOR PARTS BREAKDOWN

Item	Part #	Description	Qty
1	00057	Washer, .25 Spring Lock	4
2	00062	Nut .25nc Hex	4
4	00618	Bolt, .25 Nc X 2.00 Hex Head Gr.5	4
6	03866-95	Emergency Lever Guide	1
7	03876	Master Cylinder Cap Assembly	1
	05849	O-Ring (replacement)	
8	05424	Washer, .313 External Tooth Lock	2
9**	05679	Brake Fitting .125 Full Flow	1
10	05693-95	Spring, Safety Lever	1
11	05951	Emergency Lever	1
12	05961	Bolt, .313 Nc X .625 Hex Head Gr5	2
13	05973-95	Pin, Front Shock	1
14	05974-95	Cold Headed Clevis Pin, .625	1
15	05986-95	Cold Headed Clevis Pin, .875	2
16	05989	Push Rod Assy f/DA10	1
-	12891	Push Rod Assy f/1.25" Bore Master Cylinder	1
17	09153	Cork Gasket F/ Master Cylinder	1
18	5650	Composite Master Cyl. Kit (drum brakes)	1
-	5672	Composite Master Cyl. Kit (disc brakes)	-
-	5783	1.25" Bore Aluminum Master Cyl. Kit Disc	
19	10964***	DA10 & DA20 Spacer	2
20	10965***	DA91 & DA10 Slide Channel Top	1
21	10966***	DA91 & DA10 Slide Channel Bot	1
22	11058-??	Inner Slider Tube Chan. Down (Shown)	1
-	11053-??	Inner Slider Tube Channel Center	-
-	11063-??	Inner Slider Tube Channel Up	-
23	11068-??	DA10 Outer Case	1
24	12396	Rue Ring Lock Cotter 5/8 Shaft	1
25	12397	Rue Ring Lock Cotter, 7/8 Shaft	2
26	12557	Fill Plate for Master Cylinder	1
27	05408	Safety Cable f/Actuators	1
28	SB12426	Shock, Dampener	2
-	BH21003	Replacement Towable/Not Towable Decal	-
-	05687	Replacement Master Cyl. Protective Boot	-
-	5401	Lever Replacement Kit (incl. items w/**)	-
-	5943	Slide Replacement kit (incl. items w/***)	

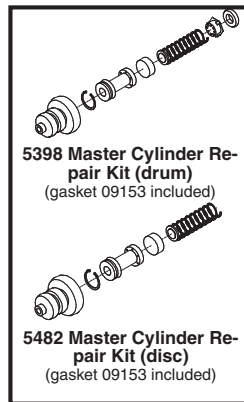

5650 Master Cyl. Replacement Kit (drum)
(gasket 09153 and fasteners included)

5672 Master Cyl. Replacement Kit (disc)
(gasket 09153 and fasteners included)

**** (OPTIONAL) BRAKE FITTING**

- 05679 - .125 Full Flow
- SB12099 - .031 Orifice
- SB12100 - .024 Orifice
- SB12098 - .016 Orifice

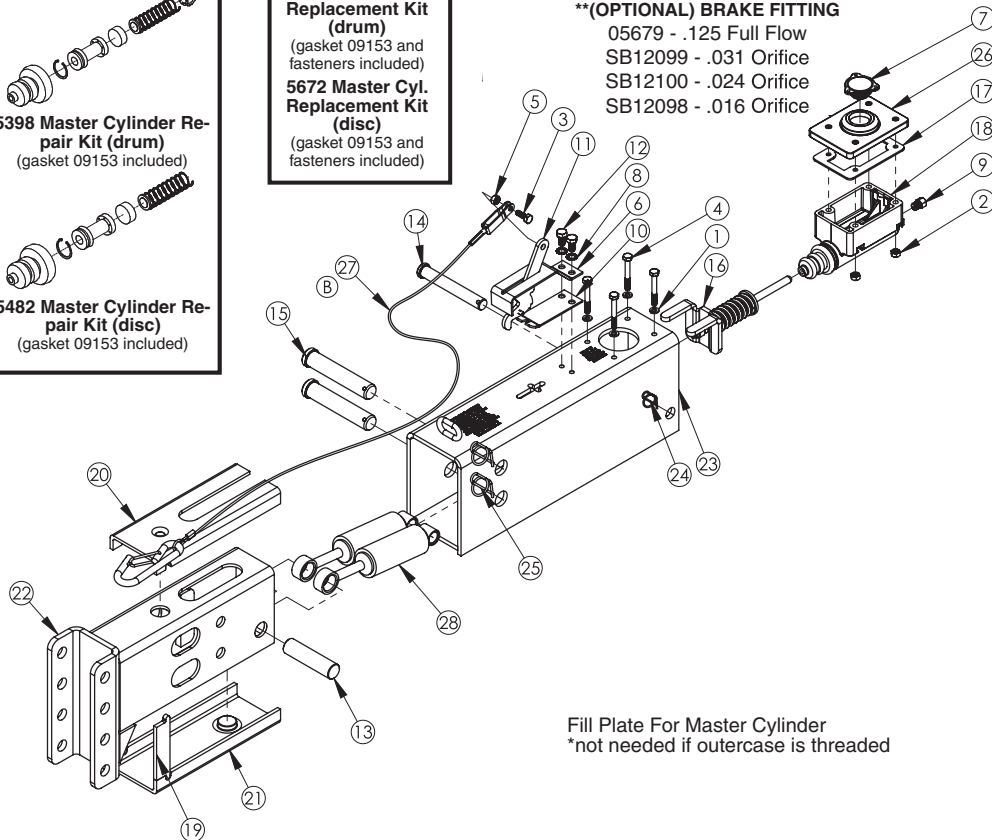

DA16 PARTS EXPLOSION

MODEL DA16 ACTUATOR PARTS BREAKDOWN

REF. NO.	PART NO.	QTY.	DESCRIPTION
1	00057	4	Washer, .25 Spring Lock
2	00068	1	Hbolt .2500-20 **
3	02772	1	Nut, .25NC Lock Nylon Insert **
4	03409-95	1	Pin, Front Stock
5	03410-95	1	Cold Headed Clevis Pin, .625
6	03411-95	2	Cold Headed Clevis Pin, .875
7	03866-95	1	Emergency Lever Guide **
8	03876	1	Master Cylinder Cap Assembly
9	04055	4	Bolt, .25-20 NC x 1 Gr5 Hex Head
10	05424	2	Washer, .313 External Tooth Lock
11	05693-95	1	Spring, Safety Lever **
12	05951	1	Emergency Lever **
13	05961	2	Bolt, .313 NC x .625 Hex Head Gr5
14	09153	1	Cork Gasket f/Master Cylinder **
15	10962 *	1	DA16 Slide Channel Top
16	10963 *	1	DA16 Slide Channel Bot
17	10964 *	2	Spacer
18	11675-95	1	Solenoid Cover
19	11724	1	DA16 Push Rod Assembly
20	12396	1	Rue Ring Lock Cotter 5/8 Shaft
21	12397	2	Rue Ring Lock Cotter 7/8 Shaft
22	12557	1	Fill Plate f/Master Cylinder Cap
23	05408	1	Safety Cable f/Actuators **
24	13738-95	1	Inner Drop Tube Assembly
25	13739-95	1	OuterCase DA16
26	35683	1	Aluminum Master Cylinder w/By-Pass
27	BD21001	2	Decal Disc Brakes
28	BH21009	1	Decal "Warning" By-Pass Solenoid
29	SB12426	2	Shock Damper
-	5401	-	Lever Replacement Kit (incl. items w/**)
-	5944	-	Slide Replacement Kit (incl. items w/**)

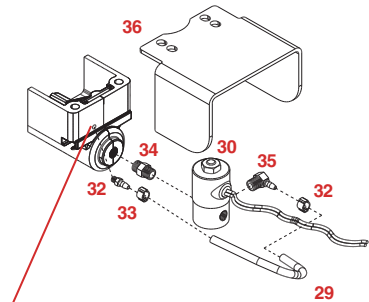

Drill the hole using a 5/32" bit. Hole location is .900" right of top left corner and .900" down from top of master cylinder. Tap hole with 10-32 NF tap

KIT #5753 PARTS LIST

REF. NO.	PART NO.	QTY.	DESCRIPTION
29.	04594	-	EPDM Black Tubing
30.	05561	1	Solenoid Valve Bypass
31.	09153	1	Master Cylinder Gasket (not shown)
32.	10373	1	Brass Fitting Str. .2 HB x 10-32 NF
33.	10374	2	Crimp Clamp
34.	10375	1	Straight Nipple 1/8" MPT x 1/8" MPT
35.	10376	1	Brass Elbow 1/8" MPT x .2 HB
36.	11675-95	1	Solenoid Cover Plate

Please order replacement parts by **PART NO. COLOR** and **DESCRIPTION**

Fill Plate for Master Cylinder Cap
not needed if OuterCase is threaded

