

11652

## 68-79 VOLKSWAGEN BEETLE

**GROSS LOAD CAPACITY WHEN USED AS A WEIGHT CARRYING HITCH: 1,000 LBS. TRAILER WEIGHT & 100 LBS. TONGUE WEIGHT.**

\*\*\*DO NOT EXCEED VEHICLE MANUFACTURER'S RECOMMENDED TOWING CAPACITY.\*\*\*

**WARNING: ALL NON-TRAILER LOADS APPLIED TO THIS PRODUCT MUST BE SUPPORTED BY 18050 STABILIZING STRAPS.**

\*\* FAILURE TO PROPERLY SUPPORT NON-TRAILER LOADS WILL VOID PRODUCT WARRANTY\*\*

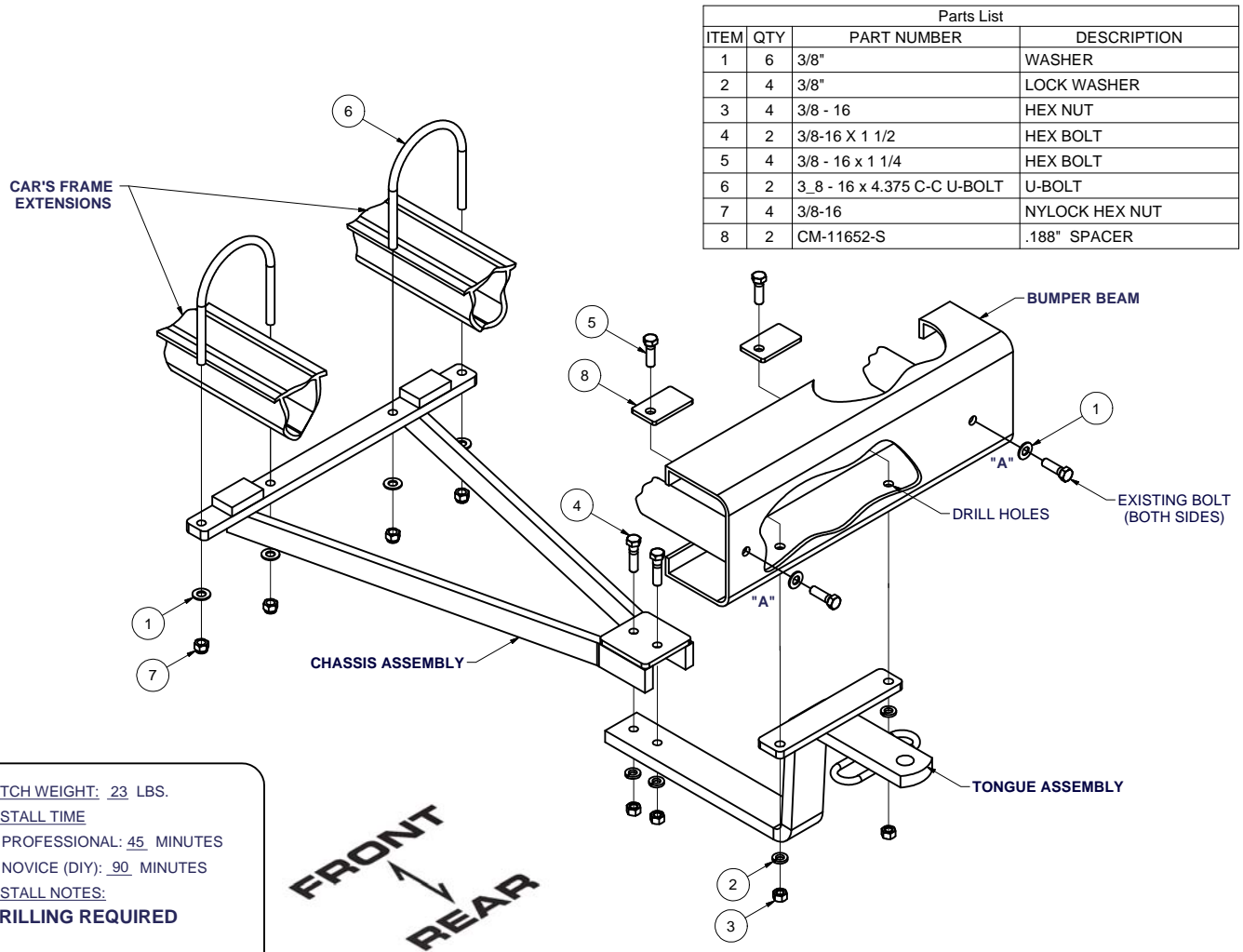

HITCH WEIGHT: 23 LBS.

**INSTALL TIME**

PROFESSIONAL: 45 MINUTES

NOVICE (DIY): 90 MINUTES

**INSTALL NOTES:**

**DRILLING REQUIRED**

## INSTALLATION STEPS

1. Fasten together the chassis and tongue assemblies using fasteners as shown.
2. To reinforce the bumper mounting points, remove one bolt on each side from under the plastic trim at "A". Reassemble the existing bolts with flat washers provided under the bolt head as shown.
3. Support the hitch under vehicle rear bumper and engine/transaxle as shown. The bracket on the hitch tongue should be located under the rear bumper. With the car elevated and supported safely, install U-bolts by passing them over the vehicle frame extensions, and through holes in chassis assembly as shown. Install nylock nuts and washers onto u-bolts.
4. Adjust the hitch to be centered and square with the rear bumper. Locate the hitch as far rearward as possible under the rear bumper, leaving room to install fasteners with backing plates INSIDE the bumper. Using the hitch as a template, drill rear bumper two places for 3/8" bolts. Install fasteners shown.
5. Torque all 3/8" fasteners to 30 lb-ft. **DO NOT USE IMPACT WRENCH ON U-BOLTS.**

PERIODICALLY CHECK THIS RECEIVER HITCH TO ENSURE THAT ALL FASTENERS ARE TIGHT AND THAT ALL STRUCTURAL COMPONENTS ARE SOUND.

Curt Manufacturing Inc., warrants this product to be free of defects in material and/or workmanship at the time of retail purchase by the original purchaser. If the product is found to be defective, Curt Manufacturing Inc., may repair or replace the product, at their option, when the product is returned, prepaid, with proof of purchase. Alteration to, misuse of, or improper installation of this product voids the warranty. Curt Manufacturing Inc.'s liability is limited to repair or replacement of products found to be defective, and specifically excludes liability for incidental or consequential loss or damage.

Looking for dependable trailer hitches and towing? Rely on CURT for quality and long-lasting products.